

TRAK Machine Tools

Site Preparation Guide

TRAK DPMRX3

Service Manual Link:

https://www.southwesternindustries.com/media/manuals/29604_manual_w_drawings.pdf

Programming Manual Link:

https://www.southwesternindustries.com/media/manuals/29603_manual.pdf

Before an Authorized Field Service Technician can perform the machine's final checkout, the following requirements must be met:

- The machine must be in position and placed on its rest pads
- To offload the machine, a 6000 lb. forklift with 6' extension is required.
- The machine must be leveled (refer to installation and service manual).
- The machine must be wired (refer to the installation and service manual).
- The machine must have air hooked up if power drawbar is installed (see the installation and service manual).
- The machine must be cleaned. Remove all grease from the way surfaces.

Space & Weight

- Floor area = 102.3" x 96.6"
- Height = 96.75"
- Footprint = 24" x 43.3125"
- Net (approx.) Weight = 4100 lbs.
- Shipping (approx.) Weight = 4400 lbs.
- Pallet Size = 76" x 76", 8" thick
- Allow clearance at the rear of the mill to open and work on the electrical box.
- A solid and level foundation to maintain approximately 4100 lbs plus the weight of the workpiece (maximum total 5500 lbs) is required. Six leveling screws are provided.

Electrical

- Machine is only available in the 208 VAC configuration (200 to 240V is acceptable). A separate 208V, 35 amps, 60 Hz, 3 phase circuit is required. For shops with 440 VAC, a step-down transformer to 208 VAC must be used. The transformer must be sized to carry a load of 35 amps minimum.
- Machine tool must be earth grounded.

Air (for optional Power Drawbar)

- 1/4" NPT connection
- Air pressure not to exceed 100 psi
- 17.5 SCFM or 2.5 CFM at 90 psi

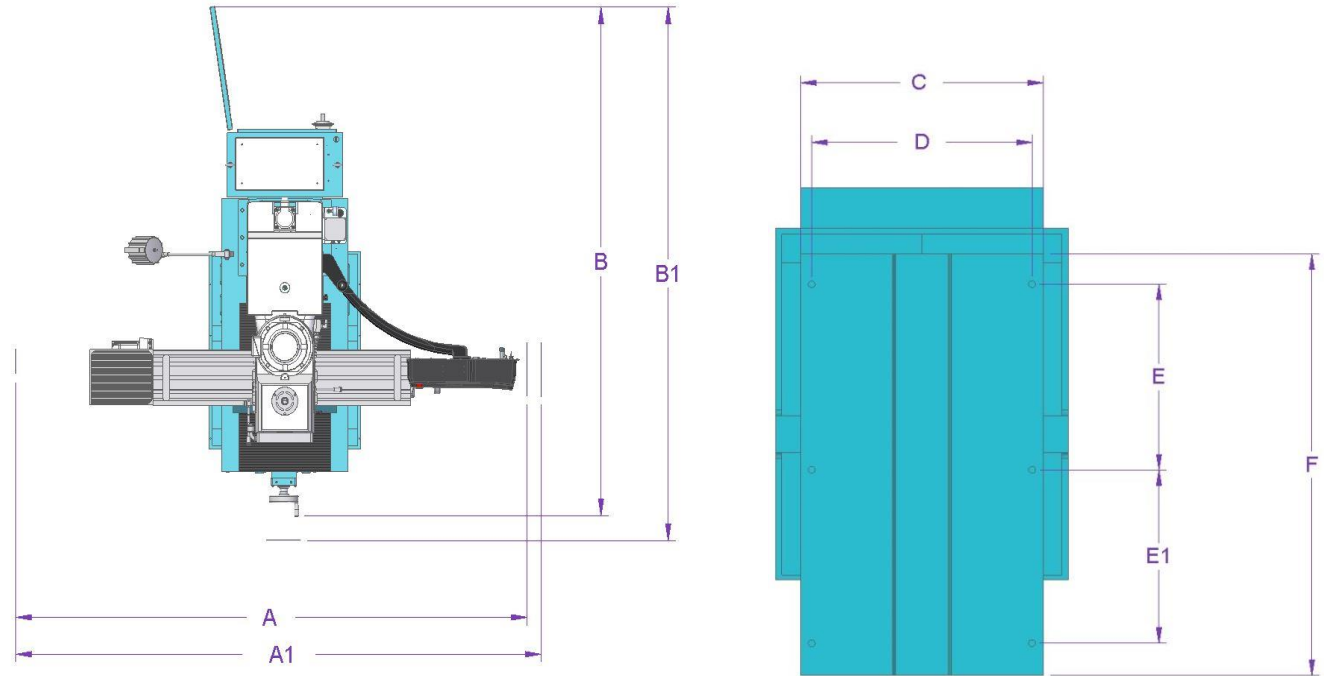

DPMRX3 Machine Footprints

A	Overall Width (With Mechanical Handwheel)	99.625"
A1	Overall Width (With Electronic Handwheel)	102.25"
B	Overall Length (With Mechanical Handwheel)	92.25"
B1	Overall Length (With Electronic Handwheel)	96.625"
C	Bed Width	24"
D	Bed Width between leveling screws	21.7"
E	Distance between leveling screws	18.75"
E1	Distance between leveling screws	17.5"
F	Bed length	43.3125"

TRAK MACHINE TOOLS



SOUTHWESTERN INDUSTRIES, INC.

TRAK Machine Tools
Site Preparation Guide
TRAK DPMRX3

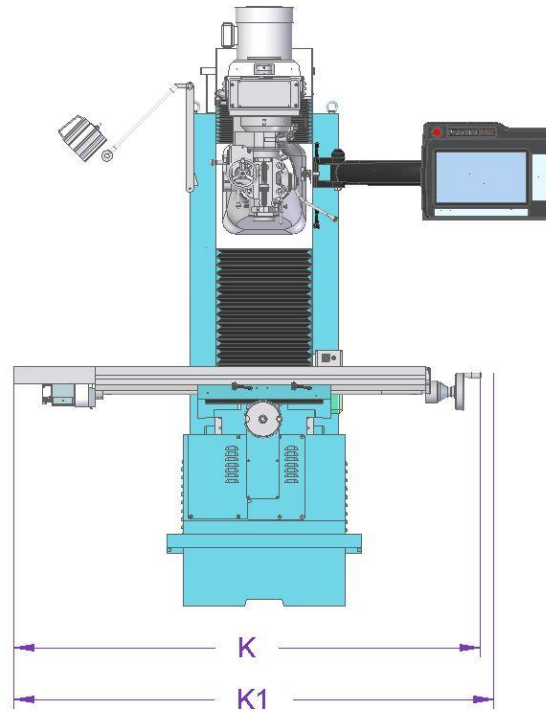
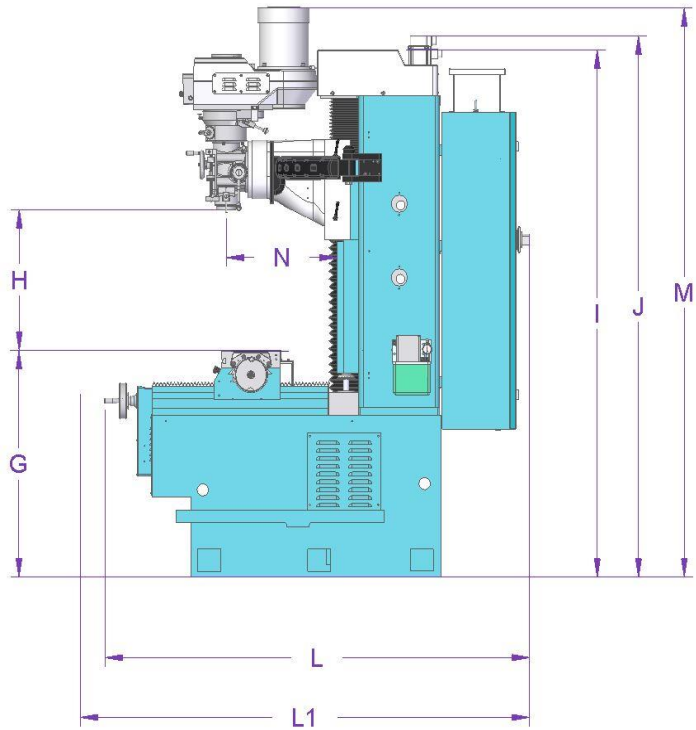

DPMRX3 Overall Dimensions

G	Height of table from bottom of bed	36.75"
H	Maximum distance from spindle nose to table	25.8125"
I	Height of machine from bottom of bed to top of column cover	84.75"
J	Max. height of machine from bottom of bed to top of Z-axis motor	87.5"
K	Width of machine (Mechanical Handwheel)	70.875"
K1	Width of machine (Electronic Handwheel)	73.5"
L	Length with electrical cabinet closed (w/ Mechanical Handwheel)	72.4375"
L1	Length with electrical cabinet closed (w/ Electronic Handwheel)	76.625"
M	Maximum height of machine from bottom of leveling pads to top of spindle motor with the head all the way up	100.5"
N	Spindle center to column face	20.5"

Note: Removing the z-axis motor, z-axis motor cover, resistor housing, resistor housing lid, and unscrewing the top resistor from its bracket and placing it to the side results in a height of 80.4375" from the bottom of base to the top of the Z-Axis ball screw. With the head all the way down, this is the minimum clearance needed to move the machine through doors.

TRAK MACHINE TOOLS

 SOUTHWESTERN INDUSTRIES, INC.

TRAK Machine Tools

Site Preparation Guide

TRAK DPMRX3

Lifting and/or Moving the Machine

Method 1 (see Figure 1):

CAUTION!

The DPMRX3 machine weighs approximately 4100 lbs. Proper equipment of sufficient capacity must be used when lifting and/or moving the machine.

1. Insert a steel bar 1.0" dia x 36" long through the rear side holes of the bed (under column).
2. Use a steel cable (with protective covering) min. 3/4" dia. or a 3 ton sling.
3. Use cardboard pieces or other suitable protective sheets on both sides of the machine to prevent scratching.
4. Remove the 4 nuts and screws holding the machine to the wood skid.
5. Lift the machine (the front side of the machine should be lower than the back side).
6. Insert the 6 screws for leveling pads in their place in the bed.
7. Place the machine in its location (see floor plan and bed footprint drawing) carefully positioning each leveling pad under each leveling screw.
8. Remove the lifting cable or sling, the steel bar and all protective cardboard.

Figure 1 Lifting the Machine Method 1

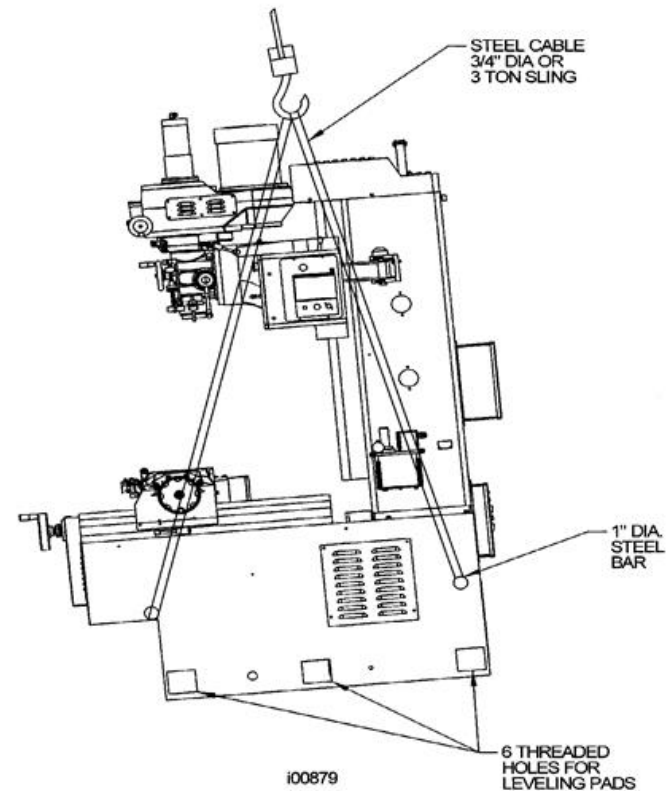

TRAK MACHINE
TOOLS



SOUTHWESTERN INDUSTRIES, INC.

TRAK Machine Tools

Site Preparation Guide

TRAK DPMRX3

Method 2 (see Figure 2):

1. Insert 2 steel bars 1" dia x 36" long through both sides in the existing holes in the machine base (front and back).
2. Position 4 (two each side) wood vee blocks under the steel bars and over a suitable lift truck.
3. Lift the machine up (somewhat tilted towards the front) 4-6" from the ground and move it to its floor plan position.

WARNING!

The lift truck must have sufficient lifting capacity (3 tons) and be equipped with suitably long forks.

4. Insert the 6 screws for the leveling pads in their place in the bed.
5. Place the machine in its location (see floor plan bed/footprint) carefully positioning each leveling pad under each leveling screw.

Figure 2
Lifting the Machine Method 2

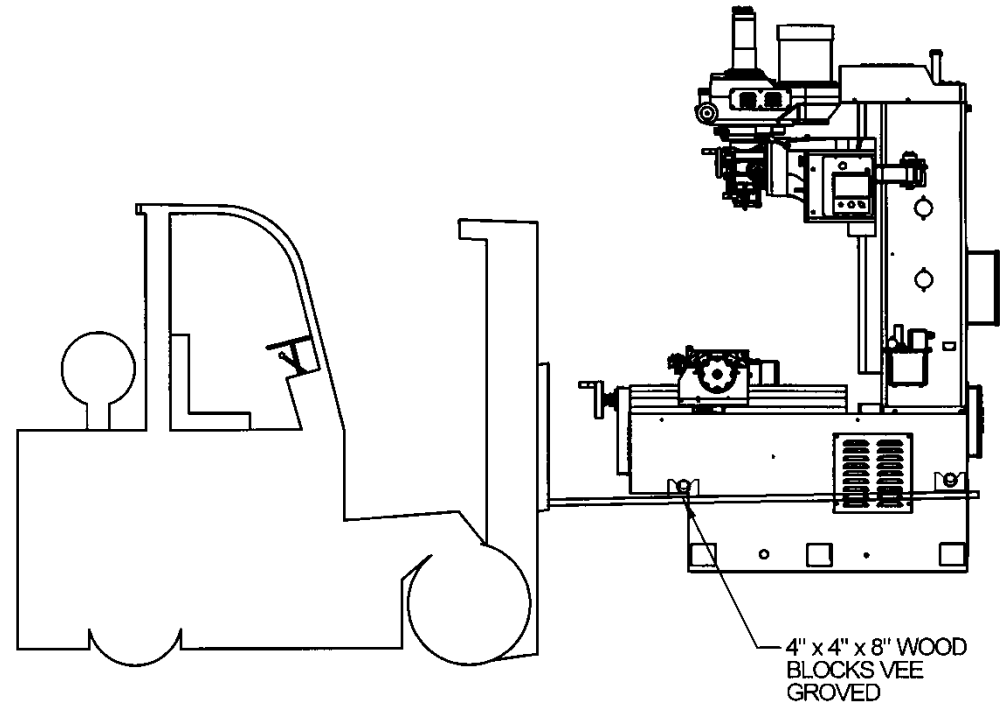

i00878