

TRAK Machine Tools Site Preparation Guide TRAK TMC12

Service Manual Link:

https://www.southwesternindustries.com/media/manuals/31551_manual.pdf

Operating Manual Link:

https://www.southwesternindustries.com/media/manuals/31550_manual.pdf

Before an Authorized Field Service Technician can perform the machine's final checkout, the following requirements must be met:

- The machine must be in position and placed on its rest pads.
- Please make sure to use a large enough forklift when lifting the TMC machine. Lift the machine when on the pallet from the column side of the machine. When removing the machine from the pallet, please note that the center of gravity (CG) of the machine is ~67" from the edge of the enclosure sheet metal. See figure 4.
- The TMC must be lifted from either the left- or right-hand sides. Make certain that the forks are squarely in the lifting cutouts beneath the machine. See the figures below.
- The TMC may be lifted via a crane with 4 points shown in figure 7 and 8.
- Once the machine is raised from the pallet, thread the adjusting screws into the bed casting. Thread the leveling screws down approximately 1.25" as measured from the bottom of the leveling bolt to the bottom of the casting. The TMC should be placed on the 4 leveling pads labeled L1, R1, L4 and R4. The remaining leveling screws should be threaded in but not touching the pad. They will be adjusted during installation.
- The machine must be wired (refer to the installation and service manual for additional information). Make sure to follow our grounding recommendations.
- The machine must have air hooked up. We strongly recommend that a water separator or air dryer be installed upstream of the TMC air supply.

Space & Weight

- Floor area (W x L) = 207" x 156.5"
- Height = 105" (min) / 120.5" (max)
- Footprint (W x L) (coolant tank in place) = 134" x 145"
- Net (approx.) Weight = 14,300 lbs.
- Shipping (approx.) Weight = 14,800 lbs.
- Pallet Size = 91" x 139"
- The floor area encompasses the space required to position the chip container and have the electrical cabinet and side doors open.
- A solid and level foundation to maintain approximately 14,300 lbs. plus the weight of the workpiece (maximum total of ~ 16,500 lbs.) is required. Ten leveling screws are provided.
- Minimum doorway width is ~86.50" and minimum height is 93" that the TMC can fit through (assumes Z motor and sheet metal on top of column are removed). The 86.50" dimension assumes you remove the pendant assembly, EHW option and heat exchanger on electrical cabinet.*
**Additional charges may apply.*

Air

- 1/2" ID minimum air connection is required.
- Air pressure must be a minimum of 90 psi.
Air – 3.0 CFM (at 90 psi), 25 SCFM

Electrical

- With a 8k spindle a separate 208 VAC (200 to 240 V is acceptable), 93 amps, 60 Hz, 3 phase circuit is required. Note – Current can be as high as 112 amps with all options ordered – CTS (+14A), 4th axis (+5A)
- With a 12k spindle a separate 208 VAC (200 to 240 V is acceptable), 96 amps, 60 Hz, 3 phase circuit is required. Note – Current can be as high as 115 amps with all options ordered – CTS (+14A), 4th axis (+5A)
- With a 8k spindle a separate 480 VAC (432 to 528 V is acceptable), 48 amps, 60 Hz, 3 phase circuit is required. Note – Current can be as high as 57 amps with all options ordered – CTS (+6A), 4th axis (+3A)
- With a 12k spindle a separate 480 VAC (432 to 528 V is acceptable), 49 amps, 60 Hz, 3 phase circuit is required. Note – Current can be as high as 58 amps with all options ordered – CTS (+6A), 4th axis (+3A)
- For 480 Volt machines, the spindle motor is run at 480 volts and the axis motors run at 220 volts. A step-down transformer is required for 480V.
- Machine tool should be earth grounded with a dedicated 8-foot long copper rod. A 2 or 6-gage ground wire (depending on voltage) should run from the copper rod to grounding location in the electrical cabinet. See figures 9 and 10.

Coolant

- Please have coolant available during installation. This machine requires 70.5 gallons.

TRAK Machine Tools
Site Preparation Guide
TRAK TMC12

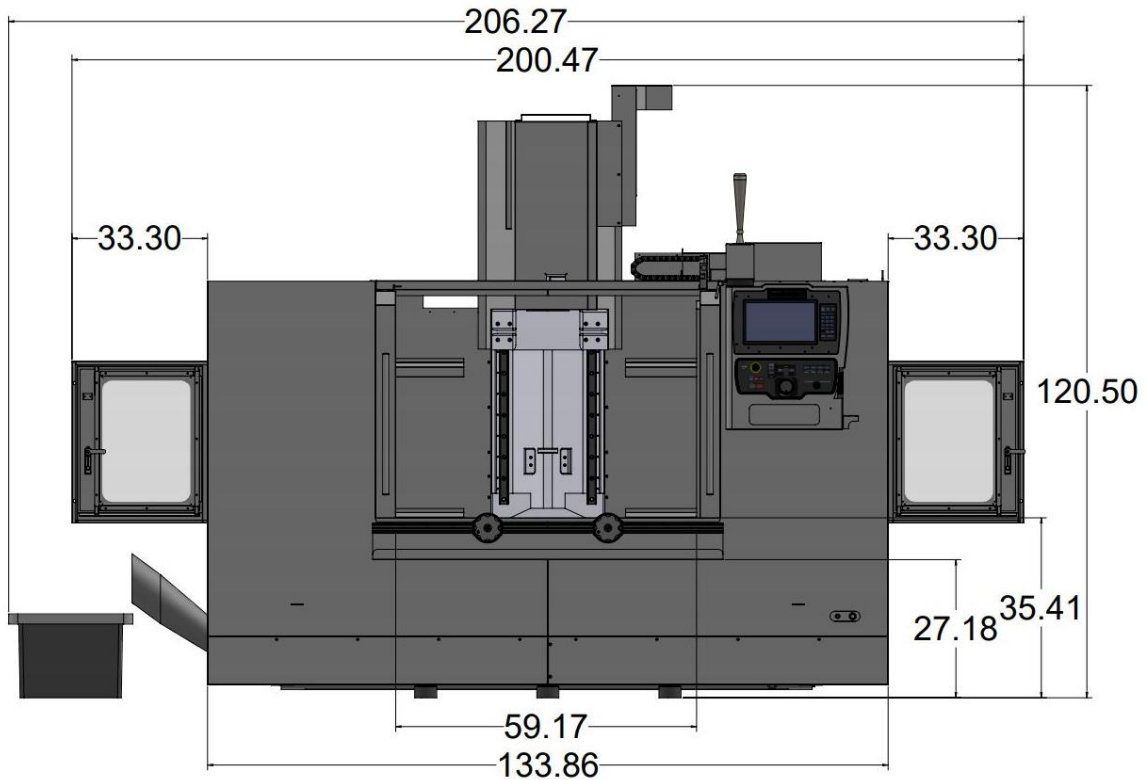

Figure 1 – Front View of Machine

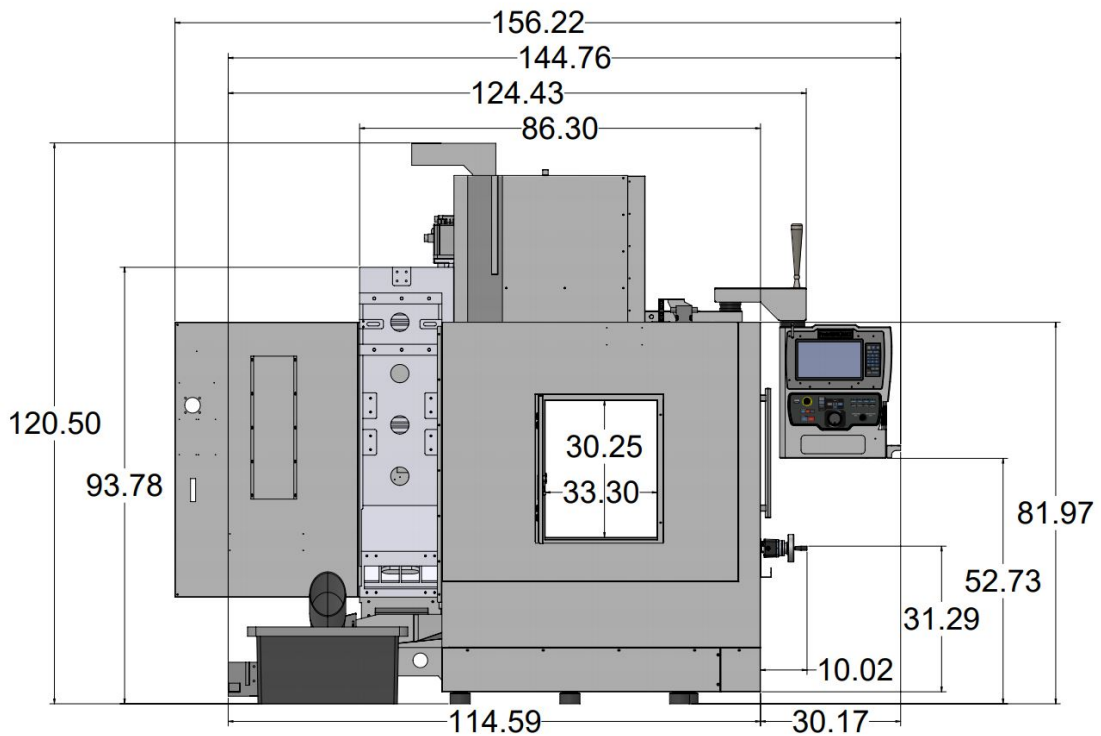

Figure 2 – Left Side View of Machine

TRAK Machine Tools
Site Preparation Guide
TRAK TMC12



Figure 3 – Lifting the TMC



Figure 4 – Lifting the TMC

TRAK Machine Tools
Site Preparation Guide
TRAK TMC12



Figure 5 – Lifting the TMC

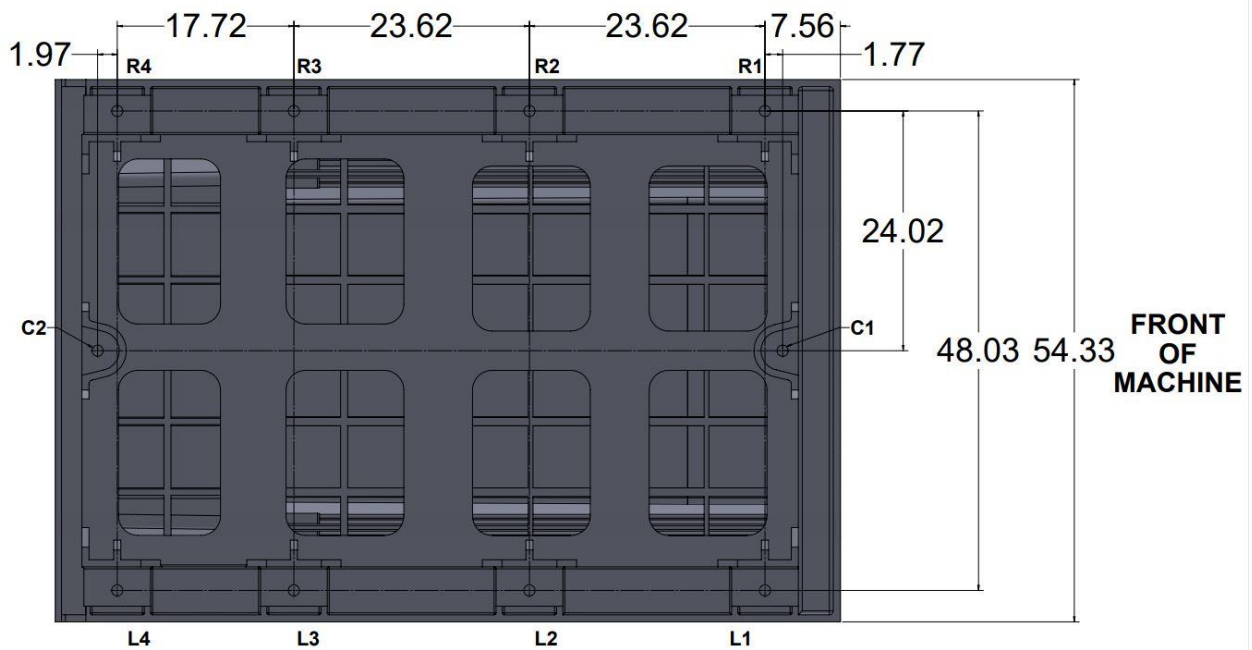

Figure 6 – Leveling Pad Locations

TRAK Machine Tools
Site Preparation Guide
TRAK TMC12

If you would like to lift the machine with a crane, the following figures show the lifting points. Note – Brackets that attach to the column and shown in figure 8 are not provided with the machine.

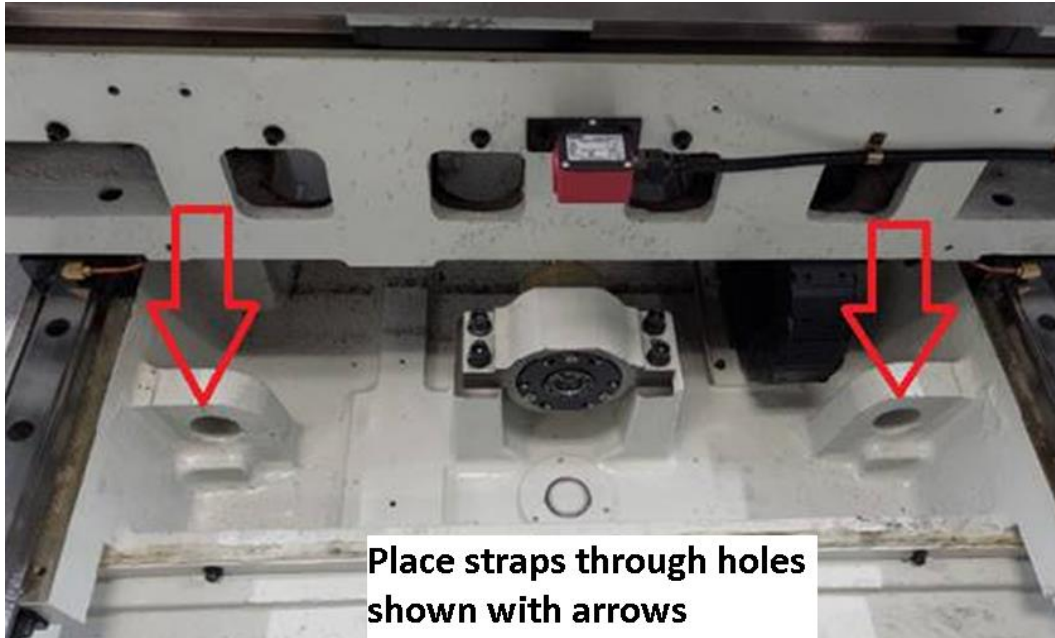

Figure 7 – Lifting Machine with Straps – Y Axis Lift Points



Figure 8 – Lifting Machine on Top of Column

Both brackets mount with (4) M12 bolts using a 50mm X 50mm bolt pattern.

TRAK Machine Tools Site Preparation Guide TRAK TMC12

Electrical Connections

Main Power to the Machine Connections

The 3 phase 208 or 480 voltage is connected to L1, L2 and L3 at the main power switch inside the electrical box. Connect the ground wire as shown in the figure 9.



Power to cabinet can be provide through side or top of cabinet. There is a knock out on top of cabinet. Make sure cabinet is sealed once power is installed.

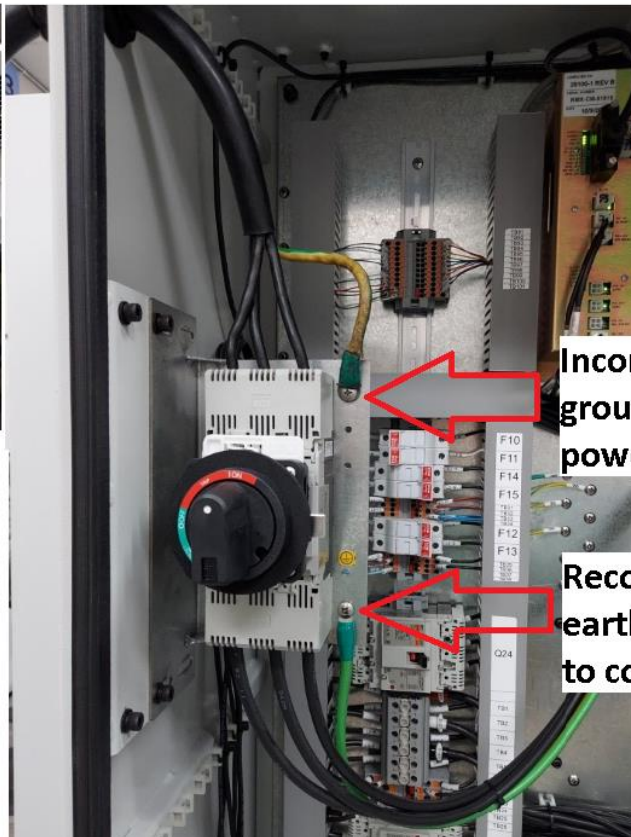

Figure 9 – Power Input and Connect the Ground Wires

Machine Grounding

It is strongly recommended that the machine be earth grounded. A dedicated copper rod 8 feet or so in length should be driven into the ground near the TMC. A ground wire should then be run from the location shown in figure 9. The copper wire should exit the electrical cabinet in the lower right-hand corner as shown in figure 10. Make sure the foam where the copper wire goes through seals the cabinet from external debris. The wire gage should be 2 gage for 208 volt machines and 6 gage for 480 volt machines.

TRAK Machine Tools
Site Preparation Guide
TRAK TMC12

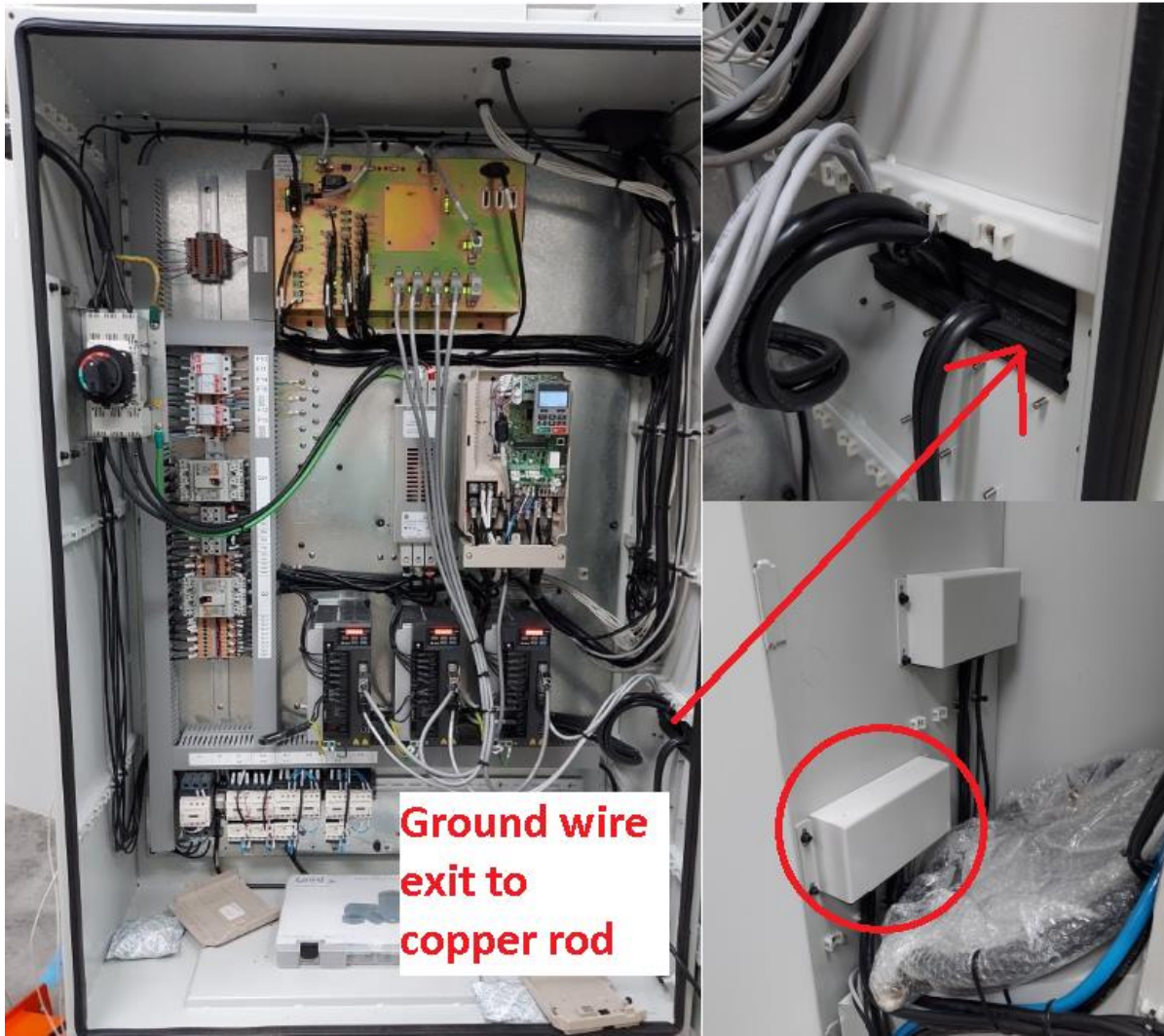

Figure 10 – Exit Location for Ground Wire to Copper Rod