

# **TRAK® DPM RMX Bed Mills**

# **ProtoTRAK® RMX CNC**

## **Safety, Installation, Maintenance, Service and Parts List**

---

Document:	P/N 29604
Version:	041222

### **Covers Models:**

- **DPMRX2**
- **DPMRX3**
- **DPMRX5**
- **DPMRX7**

**TRAK** MACHINE  
TOOLS



**SOUTHWESTERN INDUSTRIES, INC.**

2615 Homestead Place  
Rancho Dominguez, CA 90220-5610 USA  
T | 310.608.4422 | F | 310.764.2668  
Service Department: 800.367.3165

e-mail: [sales@trakmt.com](mailto:sales@trakmt.com) | [service@trakmt.com](mailto:service@trakmt.com) | web: [www.trakmt.com](http://www.trakmt.com)

Copyright © 2021, Southwestern Industries, Inc. All rights are reserved. No part of this publication may be reproduced, stored in a retrieval system, or transmitted, in any form or by any means, mechanical, photocopying, recording or otherwise, without the prior written permission of Southwestern Industries, Inc.

While every effort has been made to include all the information required for the purposes of this guide, Southwestern Industries, Inc. assumes no responsibility for inaccuracies or omission and accepts no liability for damages resulting from the use of the information contained in this guide.

All brand names and products are trademarks or registered trademarks of their respective holders.

**TRAK Machine Tools**

Southwestern Industries, Inc.

2615 Homestead Place

Rancho Dominguez, CA 90220-5610

Phone 310.608.4422 ▪ Fax 310.764.2668

Service Department

Phone 800.367.3165 ▪ Fax 310.886.8029

Web: [www.trakmt.com](http://www.trakmt.com)

# Table of Contents

---

<b>1.0</b>	<b>Safety</b>	<b>1</b>
1.1	Safety Publications .....	1
1.2	Danger, Warning, Caution, and Note Labels & Notices As Used .....	1
1.3	Safety Precautions.....	3
<b>2.0</b>	<b>Installation DPMRX2, DPMRX3, DPMRX5 &amp; DPMRX7</b>	<b>5</b>
2.1	Floor Plan, Layout & Space Requirements .....	5
2.1.1	DPMRX Machines – Overall Dimensions .....	5
2.2	Uncrating.....	8
2.3	Shortages: Inventory Checklist.....	8
2.4	Lifting and/or Moving the Machine.....	8
2.5	Electrical Connection .....	11
2.5.1	Phase Converters .....	12
2.6	Air Connection – Optional .....	12
2.7	Pendant Maintenance .....	13
2.7.1	How to Clean the Touchscreen .....	13
2.8	Mounting the Display Pendant.....	13
2.9	Pendant Cable Connections.....	13
2.10	Releasing the Head Counterweight Supports DPMRX2, DPMRX3, & DPMRX5 .....	16
2.11	Releasing the Head Counterweight Supports – DPMRX7.....	16
2.12	Cleaning .....	16
2.13	Leveling: Leveling Tolerance for DPMRX is .0005”/10” .....	17
2.14	Installation Checklist.....	18
2.14.1	Installation Instructions & Checklist.....	18
2.15	Lubrication.....	19
2.15.1	Way Lubrication – DPMRX2, DPMRX3, DPMRX5, & DPMRX7.....	19
2.15.2	Head Lubrication – TRAK Bed Mills.....	20
2.16	Machine Specifications.....	21
2.17	ProtoTRAK RMX Euclid Block Procedure .....	22
<b>3.0</b>	<b>Troubleshooting by Symptom</b>	<b>24</b>
3.1	Problems Relating to Machining Results .....	24
3.1.1	Poor Finish .....	24
3.1.2	Circles Out of Round .....	25
3.2	Problems Regarding the Motion of the Machine.....	25
3.2.1	Run Away Axis.....	25
3.2.2	Axis Will Not Jog .....	26
3.3	Problems Relating to the Operation of the Control .....	27
3.3.1	Fault X or Y or Z .....	27
3.3.2	Pendant Does Not Respond & Appears to be Locked Up .....	27
3.3.3	USB Not Working on Pendant .....	28
3.3.4	Pendant Does Not Power On.....	28
<b>4.0</b>	<b>Service Codes</b>	<b>29</b>
<b>5.0</b>	<b>Procedure for Replacements &amp; Maintenance</b>	<b>30</b>
5.1	Replacements .....	30
5.1.1	Brushless Motor Replacement .....	30
5.1.2	Servo Drive Replacement.....	30
5.1.3	Pendant and Computer Module Replacement.....	31

5.1.4	Updating the Pendant and CM Software .....	33
5.1.5	Cable Routing on Machine .....	33
5.1.6	Glass Scale Replacement .....	33
5.1.7	Power Drawbar .....	35
5.1.8	Wiring of the Auxiliary Output Function .....	36
5.1.9	Air Solenoid Replacement for Power Drawbar with Aux Function Spray Cool .....	38
5.1.10	Electronic Handwheels .....	39
5.1.11	Spindle Motor Wiring .....	39
5.1.12	Feed Trip Adjustment .....	40
5.1.13	Quill Clock Spring Replacement and Adjustment .....	41
5.1.14	Spindle Motor Removal and Replacement: DPMRX2, DPMRX3, DPMRX5, & DPMRX7 .....	42
5.1.15	Spindle Drive Belt Replacement: DPMRX2, DPMRX3, DPMRX5, & DPMRX7 .....	42
5.1.16	Spindle Replacement .....	43
5.2	Maintenance .....	44
5.2.1	How to Clean the Touchscreen .....	44
5.2.2	Gib Adjustments .....	44
5.2.3	Calibration & Backlash Constants .....	53
5.2.4	Head Rotation & Trimming .....	55
<b>6.0</b>	<b>Introduction to Self-Service</b> .....	<b>57</b>
6.1	When You Have a Service Problem .....	57
6.1.1	Communication with the Customer Service Group .....	57
6.2	Replacements .....	57
6.2.1	Exchange Program .....	57
6.2.2	Return Material Authorization (RMA) Number .....	58
	<b>TRAK Warranty Policy</b> .....	<b>59</b>
<b>7.0</b>	<b>Figures &amp; Parts List</b> .....	<b>60</b>



# 1.0 Safety

The safe operation of the TRAK Mills depends on its proper use and the precautions taken by each operator.

- Read and study this manual and the ProtoTRAK RMX Programming, Operating, and Care Manual. Be certain every operator understands the operation and safety requirements of this machine before its use.
- Always wear safety glasses and safety shoes.
- Always stop the spindle and check to ensure the CNC control is in the stop mode before changing or adjusting the tool or workpiece.
- Never wear gloves, rings, watches, long sleeves, neckties, jewelry, or other loose items when operating or around the machine.
- Use adequate point of operation safeguarding. It is the responsibility of the employer to provide and ensure point of operation safeguarding per OSHA 1910.212 - Milling Machine.

## 1.1 Safety Publications

Refer to and study the following publications for assistance in enhancing the safe use of this machine.

**Safety Requirements for Manual Milling, Drilling and Boring Machines with or without Automatic Control** (ANSI B11.8-2001). Available from The American National Standards Institute, 1819 L Street N.W., Washington D.C. 20036

**Concepts and Techniques of Machine Safeguarding** (OSHA Publication Number 3067). Available from The Publication Office - O.S.H.A., U.S. Department of Labor, 200 Constitution Avenue, NW, Washington, DC 0210.

## 1.2 Danger, Warning, Caution, and Note Labels & Notices As Used

**DANGER** - Immediate hazards that will result in severe personal injury or death. Danger labels on the machine are red in color.

**WARNING** - Hazards or unsafe practices which could result in severe personal injury and/or damage to the equipment. Warning labels on the machine are orange in color.

**CAUTION** - Hazards or unsafe practices, which could result in minor personal injury or equipment/product damage. Caution labels on the machine are yellow in color.

**NOTE** - Call attention to specific issues requiring special attention or understanding.

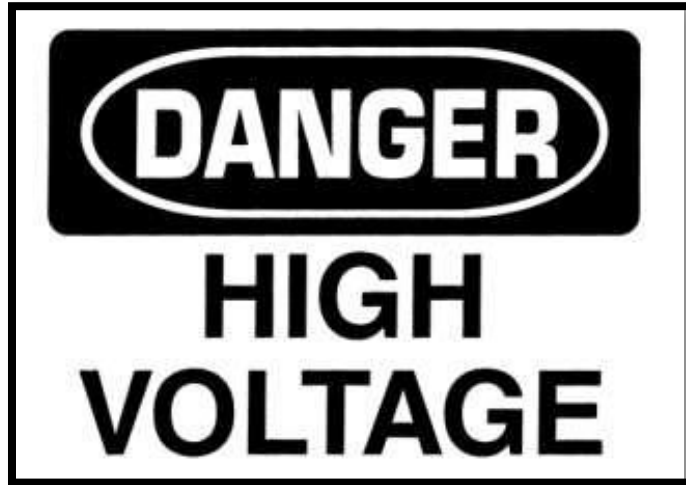

**NOTICE:** The manufacture is not liable (responsible) for any damages or injury of any kind to persons or property caused by or resulting from the improper or unauthorized use, operation, maintenance, alteration, modification, change in configuration of this machine or any of its component parts, or the use of this unit with any third party accessories or parts.

.i00775

## Safety & Information Labels Used on The TRAK Milling Machines

It is forbidden by OSHA regulations and by law to deface, destroy or remove any of these labels.

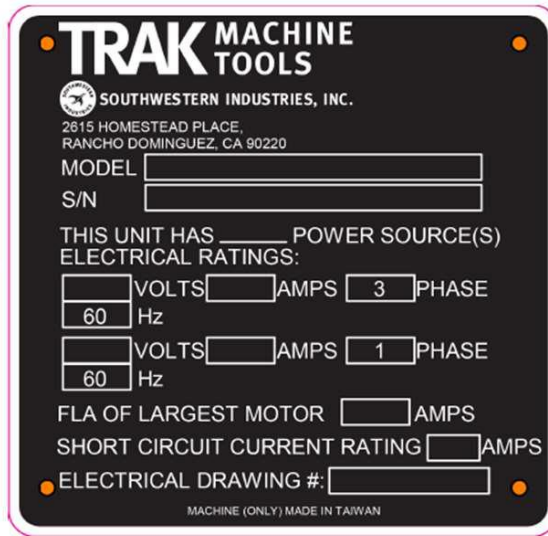

<b>Power Requirements at 208 Volts, 3-phase 60 Hz</b>				
	RX2	RX3	RX5	RX7
FLA of Largest Motor at 220 V	8.5	14	14	21
FLA of Machine at 220 V	27	35	35	42

### 1.3 Safety Precautions

1. Do not operate this machine before the TRAK DPMRX Mill Installation, Maintenance, Service and Parts List Manual, and ProtoTRAK RMX Programming, Operating & Care Manual have been studied and understood.
2. Do not run this machine without knowing the function of every control key, button, knob, or handle. Ask your supervisor or a qualified instructor for help when needed.
3. Protect your eyes. Wear approved safety glasses (with side shields) at all times.
4. Don't get caught in moving parts. Before operating this machine remove all jewelry including watches and rings, neckties, and any loose-fitting clothing.
5. Keep your hair away from moving parts. Wear adequate safety headgear.
6. Protect your feet. Wear safety shoes with oil-resistant, anti-skid soles, and steel toes.
7. Take off gloves before you start the machine. Gloves are easily caught in moving parts.
8. Remove all tools (wrenches, chuck keys, etc.) from the machine before you start. Loose items can become dangerous flying projectiles.
9. Never operate a milling machine after consuming alcoholic beverages, or taking strong medication, or while using non-prescription drugs.

10. Protect your hands. Stop the machine spindle and ensure that the CNC control is in the stop mode:
  - Before changing tools
  - Before changing parts
  - Before you clear away the chips, oil or coolant. Always use a chip scraper or brush
  - Before you make an adjustment to the part, fixture, coolant nozzle or take measurements
  - Before you open safeguards (protective shields, etc.). Never reach for the part, tool, or fixture around a safeguard.
11. Protect your eyes and the machine as well. Don't use compressed air to remove the chips or clean the machine.
12. Disconnect power to the machine before you change belts, pulley, and gears.
13. Keep work areas well lighted. Ask for additional light if needed.
14. Do not lean on the machine while it is running.
15. Prevent slippage. Keep the work area dry and clean. Remove the chips, oil, coolant and obstacles of any kind around the machine.
16. Avoid getting pinched in places where the table, saddle or spindle head create "pinch points" while in motion.
17. Securely clamp and properly locate the workpiece in the vise, on the table, or in the fixture. Use stop blocks to prevent objects from flying loose. Use proper holding clamping attachments and position them clear of the tool path.
18. Use correct cutting parameters (speed, feed, depth, and width of cut) in order to prevent tool breakage.
19. Use proper cutting tools for the job. Pay attention to the rotation of the spindle: Left hand tool for counterclockwise rotation of spindle, and right-hand tool for clockwise rotation of spindle.
20. After an emergency stop, release the E-stop and press the power reset button for 2 seconds to turn the servos back on.
21. Prevent damage to the workpiece or the cutting tool. Never start the machine (including the rotation of the spindle) if the tool is in contact with the part.
22. Check the direction (+ or -) of movement of the table, saddle, and quill when using the jog or power feed or ram out.
23. Don't use dull or damaged cutting tools. They break easily and become airborne. Inspect the sharpness of the edges, and the integrity of cutting tools and their holders. Use proper length for the tool.
24. Large overhang on cutting tools when not required result in accidents and damaged parts.
25. Handwheels must have the crank folded inside when using CNC programmed machining or rapid feeds, power feed or jog.
26. Prevent fires. When machining certain materials (magnesium, etc.) the chips and dust are highly flammable. Obtain special instruction from you supervisor before machining these materials. Keep flammable materials and fluids away from the machine and hot, flying chips.
27. Interlocked table guards may be purchased from Southwestern Industries, Inc. if deemed necessary by the user.

## 2.0 Installation DPMRX2, DPMRX3, DPMRX5 & DPMRX7

Read and understand this entire installation section before beginning the installation procedure.

### 2.1 Floor Plan, Layout & Space Requirements

#### 2.1.1 DPMRX Machines – Overall Dimensions

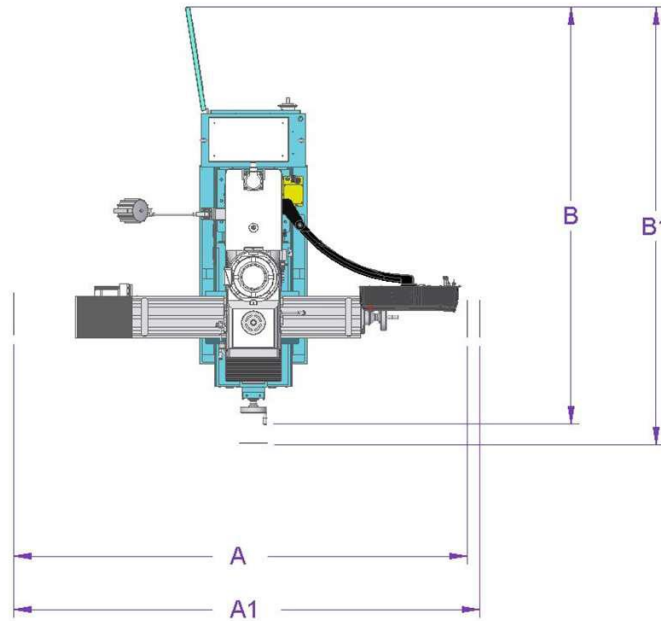

		<b>DPMRX2</b>	<b>DPMRX3</b>	<b>DPMRX5</b>	<b>DPMRX7</b>
<b>A</b>	Overall Width (With mechanical handwheel)	99.9375"	99.625"	131.0625"	168.5"
<b>A1</b>	Overall Width (With electronic handwheel)	102.5625"	102.25"	103"	119"
<b>B</b>	Overall Length (With mechanical handwheel)	89.5"	92.25"	N/A	N/A
<b>B1</b>	Overall Length (With electronic handwheel)	93.875"	96.625"	94.125"	110"

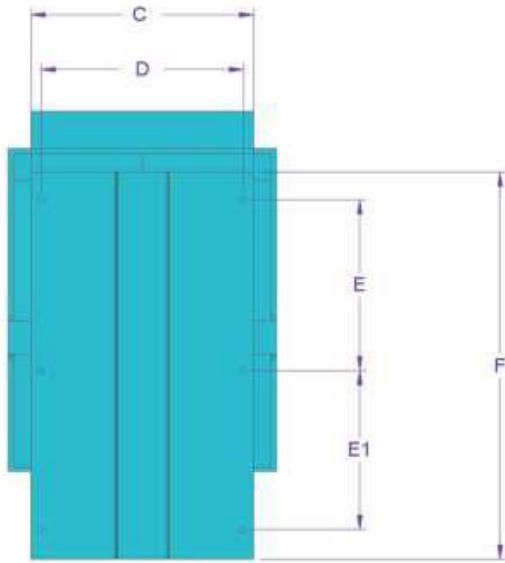
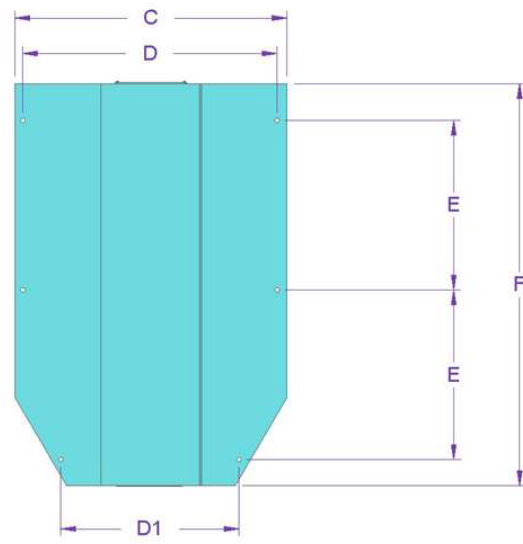
**DPMRX3****DPMRX7**

		<b>DPMRX2</b>	<b>DPMRX3</b>	<b>DPMRX5</b>	<b>DPMRX7</b>
<b>C</b>	Bed Width	23.125"	24"	24"	42.52"
<b>D</b>	Bed Width between leveling screws	20.5"	21.7"	21.7"	39.76"
<b>D1</b>	Bed Width between leveling screws	N/A	N/A	N/A	26.57"
<b>E</b>	Distance between leveling screws	32.5"	18.75"	20.5"	26.57"
<b>E1</b>	Distance between leveling screws	N/A	17.5"	N/A	N/A
<b>F</b>	Bed Length	93.875"	43.3125"	48.4"	63"

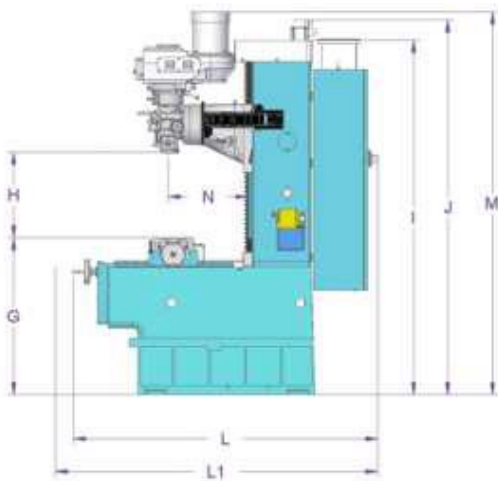
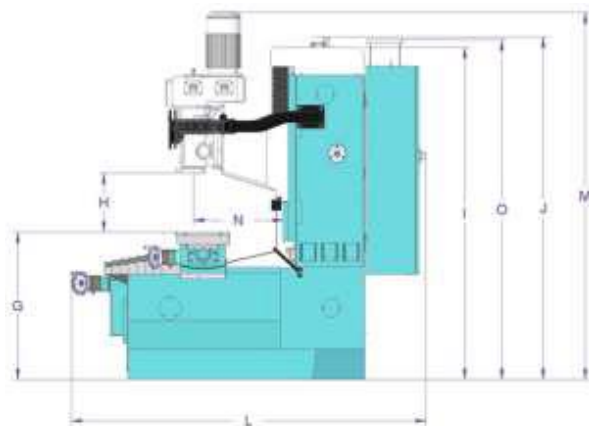
**DPMRX 2/3/5****DPMRX7**

		<b>DPMRX2</b>	<b>DPMRX3</b>	<b>DPMRX5</b>	<b>DPMRX7</b>
<b>G</b>	Height of table from bottom of bed	36.75"	36.75"	40"	38.75"
<b>H</b>	Maximum distance from spindle nose to table	20.5"	21.7"	21.7"	39.76"
<b>I</b>	Height of machine from bottom of bed to top of column cover	N/A	N/A	N/A	26.57"
<b>J</b>	Maximum height of machine from bottom of bed to top of Z-axis motor	32.5"	18.75"	87.5"	87.875"
<b>L</b>	Length of machine with electrical cabinet closed (With electronic handwheel)	69"	72.4375"	N/A	N/A
<b>L1</b>	Bed Length Length of machine with electrical cabinet closed (With electronic handwheel)	73.3125"	76.625"	82.5"	94.5"
<b>M</b>	Maximum height of machine from bottom of leveling pads to top of spindle motor with the head all the way up	98.75"	100.5"	102"	105"
<b>N</b>	Spindle center to column face	18.5"	20.5"	20.5"	24"
<b>O</b>	Bottom of Bed to Top of Electrical Cabinet	N/A	N/A	N/A	87.25"

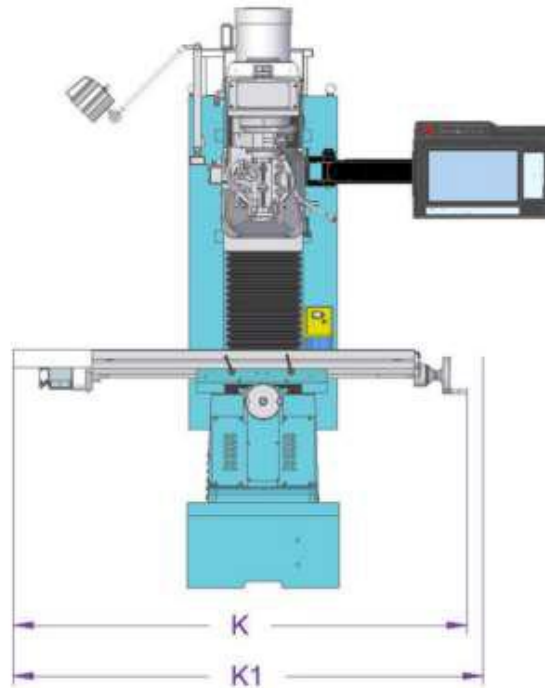

		<b>DPMRX2</b>	<b>DPMRX3</b>	<b>DPMRX5</b>	<b>DPMRX7</b>
<b>K</b>	Width of machine (Mechanical Handwheel)	69"	70.875"	N/A	N/A
<b>K1</b>	Width of machine (Electronic Handwheel, including table tray)	71.625"	73.5"	94.125"	110"

## 2.2 Uncrating

Carefully remove the wood crate and protective packaging, paying attention not to scratch, damage, or mar any parts of the machine.

Remove the cardboard boxes with the PENDANT DISPLAY (handle carefully), and the box containing the TOOL BOX. The leveling pads and screws for the machine can be found in the toolbox. The X axis way covers and end tables for the DPMRX5 & DPMRX7 are shipped in a separate box. The manual drawbar can be found in a box as well. The electronic hand wheels have been removed and placed in box with the cable still attached.

Remove two steel bars - 1.0 inch in diameter. These items are necessary for lifting and moving the machine.

Loosen and remove 4 screws and nuts holding the machine to the wood pallet.

### ATTENTION!

Immediately report, in writing, any damages observed at this time that can be attributed to the transportation or improper handling/moving of the machine.

## 2.3 Shortages: Inventory Checklist

<input type="checkbox"/>	Machine (check model and serial number)
<input type="checkbox"/>	Manual drawbar with washer
<input type="checkbox"/>	Leveling pads (B239) and screws (B240). Note 4 each for DPMRX2, 6 each for DPMRX3 and DPMRX5. Leveling pads (H-103-14) and screws (24524) 6 each for DPMRX7
<input type="checkbox"/>	X-axis way cover DPMRX5 only, (22375 & 22375-1)
<input type="checkbox"/>	X-axis way cover DPMRX7 only, (24505)
<input type="checkbox"/>	Pendant Display with (4) M56B-1.0X25 screws
<input type="checkbox"/>	Toolbox with various items
<input type="checkbox"/>	TRAK MT RMX Safety, Operation & Programming Manual (P/N 29603)
<input type="checkbox"/>	TRAK MT DPMRX2, DPMRX3, DPMRX5 & DPMRX7 Safety, Installation, Maintenance, Service & Parts List Manual (P/N 29604)
<input type="checkbox"/>	Manual Z-Axis crank (16793) N/A to DPMRX2 and DPMRX7

## 2.4 Lifting and/or Moving the Machine

### CAUTION!

The DPMRX2, RX3, RX5 & RX7 machines weigh approximately 3200, 4100, 4400 and 7500 lbs. respectively. Proper equipment of sufficient capacity must be used when lifting and/or moving the machine.

#### Method 1:

(See Figure 5)

1. Insert a steel bar 1.0" dia x 36" long through the rear side holes of the bed (under column) for DPMRX2, RX3 & RX5. Use 1-3/4" dia. X 60" long steel bar for the DPMRX7.
2. Use a steel cable (with protective covering) min. 3/4" dia. or a 3-ton sling.
3. Use cardboard pieces or other suitable protective sheets on both sides of the machine to prevent scratching.
4. Remove the 4 nuts and screws holding the machine to the wood skid.



5. Lift the machine (the front side of the machine should be lower than the back side).
6. Insert the 6 screws for leveling pads in their place in the bed. 4 screws for DPMRX2.
7. Place the machine in its location (see floor plan and bed footprint drawing) carefully positioning each leveling pad under each leveling screw.
8. Remove the lifting cable or sling, the steel bar and all protective cardboard.

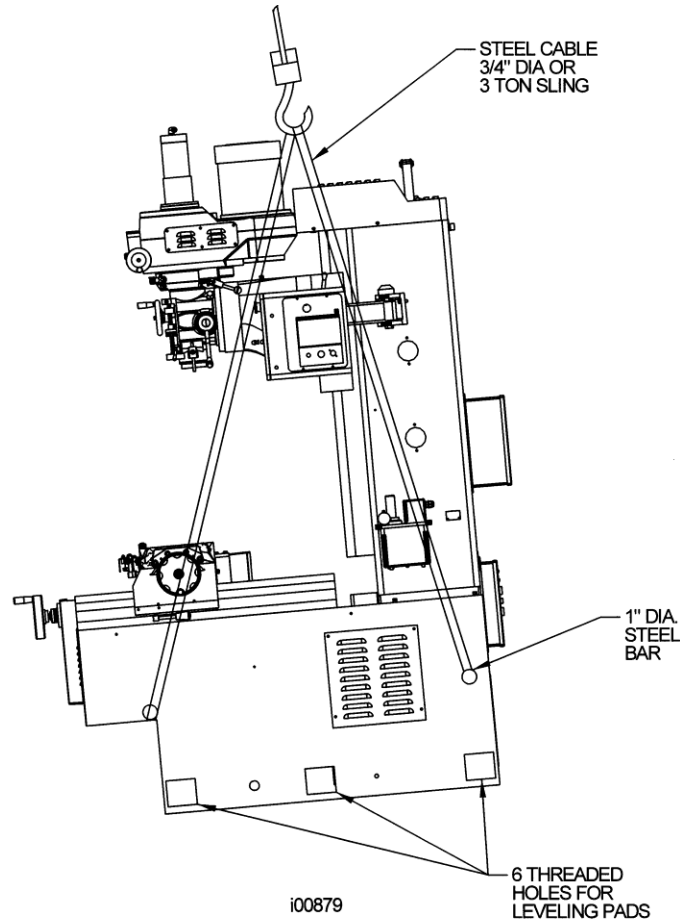

**Figure 5 –Lifting the Machine: Method 1**

**Method 2:**

(See Figure 6)

1. Insert 2 steel bars 1" dia x 36" long through both sides in the existing holes in the machine base (front and back). Use 1-3/4" dia. X 60" long steel bar for the DPMRX7.
2. Position 4 (two each side) wood vee blocks under the steel bars and over a suitable lift truck.
3. Lift the machine up (somewhat tilted towards the front) 4-6" from the ground and move it to its floor plan position.

**WARNING!**

The lift truck must have sufficient lifting capacity (3 tons) and be equipped with suitably long forks for the DPMRX2, RX3, & RX5. The lift truck must have sufficient lifting capacity (5 tons) and be equipped with suitably long forks for the DPMRX7.

4. Insert the 6 screws for the leveling pads in their place in the bed.
5. Place the machine in its location (see floor plan bed/footprint) carefully positioning each leveling pad under each leveling screw.

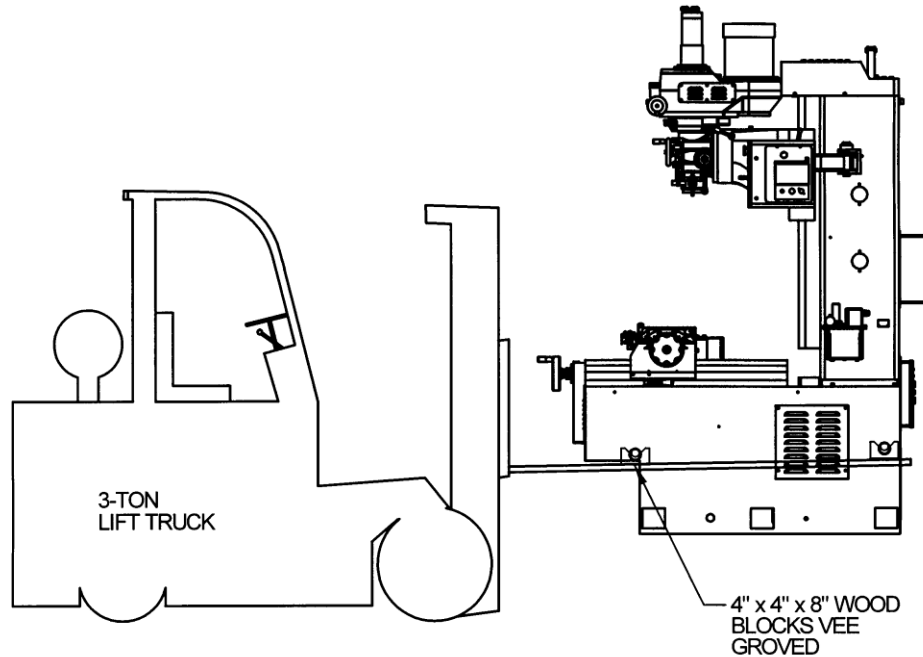

i00878

**Figure 6 – Lifting the Machine: Method 2**

**Method 3 (For DPMRX7 Only):**

**WARNING!**

The DPMRX7 machine weighs approximately 7500 lbs. The lift truck must have sufficient lifting capacity (15000 lbs.) with a 24" load center or equivalent, and be equipped with 6 ft. extension forks.

1. Using the recommended size forklift, lift the pallet with the machine on thru the fork pocket. (Note: The center of gravity (CG) of the machine while on the pallet is 42" from the edge of the pallet.)
2. Using (4) pieces of 4" x 4" x 6" high steel block. Equally, position the steel blocks to the front, back and side of the machine base.
3. Gradually lower the lift and let the machine base rest on the (4) steel blocks. (Note: Machine weight must be equally distributed and well supported by the (4) steel blocks also make sure that the position of the blocks does not obstruct the skid.)
4. Remove forklift from steel pallet.
5. Remove the (4) bolts securing the machine base to the pallet and let the steel pallet rest on the floor.
6. Carefully lift the machine thru the fork access cut out on the side of the machine.
7. Remove steel pallet under the machine.

8. Insert the (6) leveling screws into place.
9. Position and lower the machine to its location (see floor plan bed/footprint). (Note: Make sure to position each leveling pads under each leveling screws.)

## 2.5 Electrical Connection

The DPMRX2, RX3, RX5 & RX7 Bed Mills are configured for 208-volt 3 phase electricity (200 to 240 volts is acceptable).

If 440-volt, 3 phase power is present, you must use a step down transformer to 208-volt, 3 phase. The transformer for a DPMRX2 must have a rating of 10.3 KVA or greater. For the DPMRX3 and DPMRX5, the transformer must have a rating of 13.3KVA or greater. For the DPMRX7, the transformer must have a rating of 16.1KVA or greater.

**DANGER!**

Be certain that 208-volt electricity (typical range 200 – 240V) is used.

**DANGER!**

The 220-volt line must originate from a dedicated and independent fused box with a manual shut-off lever. It is the responsibility of the purchaser to supply a wired box that meets all local codes and regulations.

Incoming 208 V power connects to the machine through the electrical box located on the back of the column. The power cable enters the electric's box through a hole on the top of the box.

Southwestern Industries recommends the machine be earth grounded by driving a copper rod into the ground. It is the responsibility of the customer to install this rod.

**DANGER!**

Only a qualified electrician should wire the 208-volt 3 phase electricity.

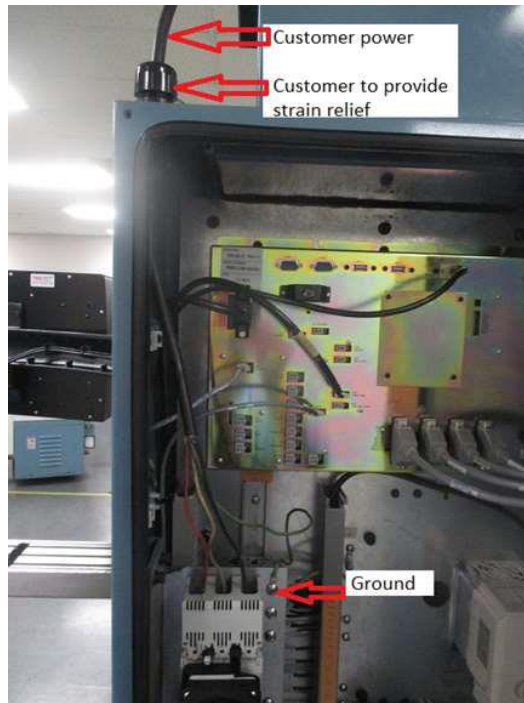

### 2.5.1 Phase Converters

For those machines that will be run with a phase converter it is recommended that it is a CNC rotary type rather than a static phase converter. CNC rotary phase converters allow for varying loads in the system. The electrical load on the machine will vary based on the type of cut taken. Static phase converters can only be used on machines with a non-varying load. The phase converter for the DPMRX machines must be rated at a minimum of 10 to 15 KVA for DPMRX2, 15 to 20 KVA for DPMRX3 & DPMRX5 and 20 to 25 KVA for DPM RX7.

## 2.6 Air Connection – Optional

The DPMRX machines have an air hookup in the rear of the machine if the machine has a power drawbar or auxiliary function option.

The drawbar option includes an air regulator, air manifold and an oiler. The auxiliary option includes an air regulator, air manifold and a solenoid. If both options are included on the same machine, a regulator, manifold, oiler and solenoid will be included. The air fitting is ¼" NPT. An additional air line port is on the manifold to be used for an optional mister. Remove the plug to gain access to this port.

(See Figure 13)

The air regulator is set to 90 PSI at the factory for the power drawbar unit and solenoid. See Section 5.1.8 for more information on the power drawbar unit. The air comes in through the manifold and passes through the air regulator. The regulator branches into two components--an oiler for the power drawbar unit and an air solenoid. The solenoid is used for a misting system that the user may install later on this machine. The mister air hose can be plugged into the ¼" quick disconnect air fitting on the solenoid. See the figure below for an illustration.

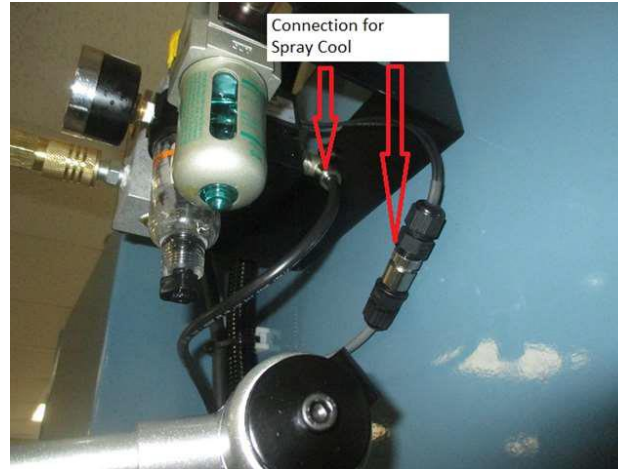

## 2.7 Pendant Maintenance

### 2.7.1 How to Clean the Touchscreen

When cleaning the touchscreen, make sure to turn off the machine. You can use any window cleaning solution to get any debris off of the screen. It is preferable to use a non-lint cloth when cleaning.

**Note** – If you clean the screen with the power on, you may get false triggering or no touchscreen detection at all.

## 2.8 Mounting the Display Pendant

The ProtoTRAK RMX display pendant mounts to the pendant arm with four M6 x 25 SHCS with flat washer and serrated washer that are shipped screwed into the left side of the display. There is a locating screw on the pendant arm to help align the pendant with the mounting holes.

### **CAUTION!**

The locating screw in the arm is used for positioning. Keep a hold of the pendant until the screws are fastened.

If the pendant arm rotates too freely, remove the painted cap on the bracket attached to the column and tighten the hex nut to adjust it. Replace the cap.

## 2.9 Pendant Cable Connections

All cable interconnections are made at the factory except for those connecting to the pendant display. There are a total of 2 cables that need to be connected to the pendant.

(See Figure 117a or Figure 134 for a complete illustration of cable interconnections for all components.)

With the main power to the machine turned off, plug in the (2) connectors that are on the pendant arm. Use the label on the pendant to match the connectors with the correct port.

Make sure there is sufficient slack in the cables for the pendant to rotate about the pendant arm. The worst case is when the pendant is all the way forward toward the operator. The following drawing describes all of the cable connections to the pendant.

Make sure that an USB option key is plugged into the option key port of the pendant. This key activates any converters or options ordered. The part # for this key is 23770-7. The key must be programmed according to the type of machine it is on and the options ordered. It is recommended to connect the Option Key to USB 5 port.

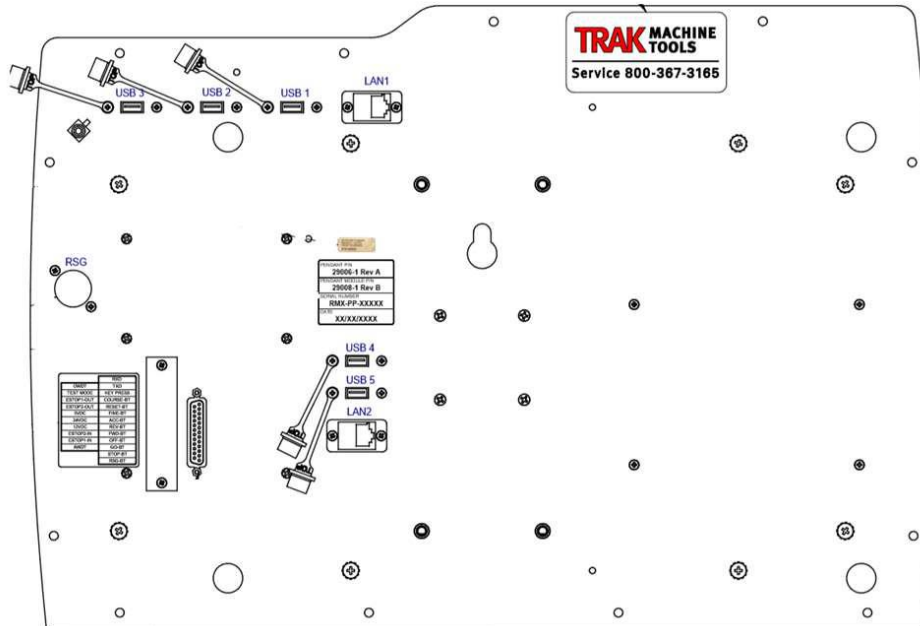

**List of Connectors:**

1. USB 1, 2 and 3 – User USB ports.
2. LAN1 – The user will use this port to network the control.
3. RSG – This is where a user will plug the remote stop-go switch.
4. USB 4 and 5 – One of these ports will contain the option key, the other one could be used by the user if need be.
5. LAN2 – Network connector used to communicate with our computer module.
6. DB25 connector – cable runs to our computer module. See section 1.11 for the list of LED's and how they can be used to troubleshoot problems.

**Mill Computer Module – USA**



**Machine ID Key**

Make sure that the Machine ID key is plugged into the port on the computer module inside the electrical cabinet, or the machine will not run.

**CAUTION!**

Make sure the main power is turned off on the back of the electrical cabinet before plugging in the cables.



## 2.10 Releasing the Head Counterweight Supports DPMRX2, DPMRX3, & DPMRX5

In order to move (raise or lower) the spindle head/ram it is first necessary to remove the 2 steel rods (with flanges) inserted through the holes in the column. These rods support the counterweight during shipping to prevent damage to the counterweight chains and sprockets.

1. Release ram gib locks.
2. DPMRX2 – Lower the head slowly with a 10mm socket on the top end of the Z-axis ball screw until the chain between the ram and the counterweight is tight. DPMRX3 & SX5 – Lower the head slowly with the ram crank until the chain between the ram and counter weight is tight.
3. Lower a little further until the 2 support steel rods are loose. Remove the 2 steel rods and store them for future machine moves or transportation.
4. Do not continue to move the ram until all ways have been cleaned.

### **CAUTION!**

Do not remove the steel rods unless they are loose.

## 2.11 Releasing the Head Counterweight Supports – DPMRX7

In order to move (raise or lower) the spindle head/ram, it is first necessary to remove the retaining plug that supports the counterweight located on the right side of the machine. The retaining plug support the counterweight during shipping to prevent damage to the counterweights chains and sprocket.

1. Release the spindle head/ram gib lock.
2. Using an M8 Allen wrench, turn the Z-axis ball screw at the top of the column to slowly raise the spindle head/ram. Remove the wood block that supports the spindle head/ram during shipment.
3. Remove the (3) socket head cap screws that secure the counterweight-retaining plug to the column.
4. Using an M14 Allen wrench, remove the bolt that secures the retaining plug to the counterweight.
5. Lower the spindle head/ram slowly until the chain between the ram and the counterweight is tight.
6. Lower the spindle head/ram a little further until the retaining plug is loose. Remove retaining plug and store them for future use.
7. Do not continue to move the spindle head/ram until all ways have been cleaned.

## 2.12 Cleaning

1. Remove rust protective coating from the machine before moving any slideways (table, saddle, ram, etc.).

### **WARNING!**

Do not use gasoline or other flammable cleaning agents for cleaning the machine.

2. The coating is best removed with clean, dry rags. Do not use a cleaning solution that may damage the rubber way scrapers, plastic parts, or paint.
3. It may be necessary to move back and forward, left and right, and up and down the table, saddle and the ram. Always release the clamp levers (two in front of the table, one underneath the



saddle on each side, and two on the ram on the right side of the column) before attempting to move the above parts.

**CAUTION!**

Never move any of the above parts over ways that were not previously cleaned. Serious damage to the TURCITE surface of slideways can occur.

4. Be certain the table, saddle, ram, and spindle move freely and smoothly over their entire length.

## 2.13 Leveling: Leveling Tolerance for DPMRX is .0005"/10"

1. Set the machine on its 6 leveling pads on a solid, level floor prepared in accordance with the state and local rules for machine tool installation. The DPMRX2 only uses 4 leveling screws.
2. Put one or two precision Spirit Levels or Electronic Levels in the center of the table in the positions illustrated in Figure 7.
3. Adjust the 4 corner leveling screws on their pads until the machine is level to .0005 in/10 in. Snug the 2 middle leveling screws being careful to not affect the level for the DPMRX3, DPMRX5 & DPMRX7.
4. If the machine must be anchored to the floor, follow the general instruction for installing machine tools and use for leveling any well-known methods: shims, etc.).
5. If the machine must be installed on vibration mounts/pads (rubber, commercially available leveling and vibration mounts, etc.) follow the instructions delivered with the mounts/pads, ordering them to satisfy the load of the machine and the maximum weight of the workpiece (6,000 lb.) for DOMRX2, DPMRX3 & DPMRX5. The maximum weight of the machine and workpiece for the DPMRX7 is 10,000 lbs.
6. When machine is correctly level, lock the adjusting screws in place with their hex nuts.

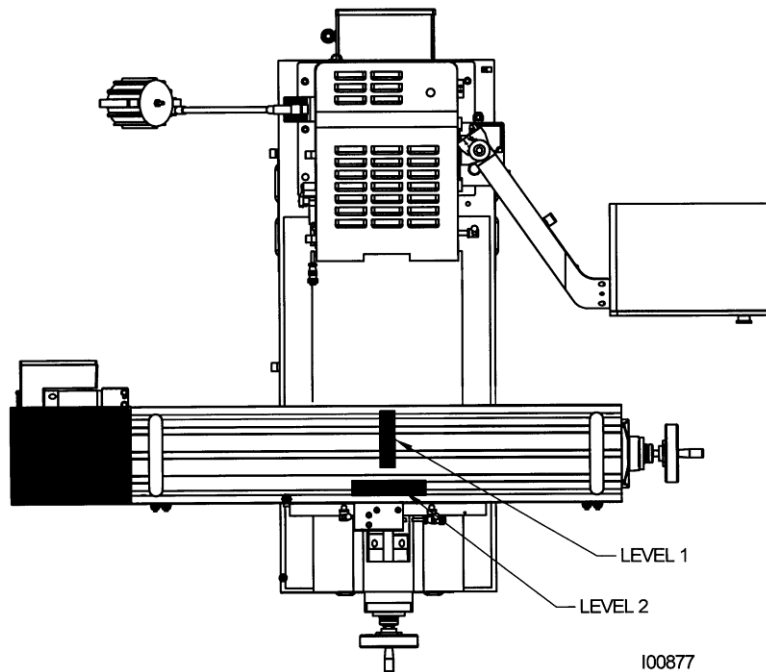

**Figure 7: Placement of Levels**

## 2.14 Installation Checklist

### 2.14.1 Installation Instructions & Checklist

Installer: Use this checklist to assure a complete set-up of a RMX machine.

<input type="checkbox"/>	Shut off power to the machine.
<input type="checkbox"/>	Visually inspect the 200 to 240V. Visually verify the wiring is correct per our wiring diagram. Make sure a strain relief is being used where the wiring enters the cabinet. Have the customer repair any wiring discrepancies. Measure the 200 to 240-volt input power to make sure it is within specification. If not, notify customer and report on service report.
<input type="checkbox"/>	Clean the machine if needed and remove any remaining grease.
<input type="checkbox"/>	Unlock the table, saddle, and ram gib locks.
<input type="checkbox"/>	Remove zip ties holding the counterweight chains in place during shipment.
<input type="checkbox"/>	Use a 10mm socket to turn the Z-axis ball screw at the top of the column. Raise the head slightly so you can remove the wood block that supports the head. Once this is done, lower the head until the counterweight is raised off of the counterweight support rods and tension is seen in the chains. (DPMRX2 only)
<input type="checkbox"/>	Remove the 2 bottom head supports. (DPMRX3 & RX5 only)
<input type="checkbox"/>	Remove the bottom head way cover and then install the manual Z-axis hand crank. (DPMRX3 & RX5 only)
<input type="checkbox"/>	Using the manual hand crank, lower the head until the counterweight is raised off of the counterweight support rods and tension is seen on the chains.
<input type="checkbox"/>	For the DPMRX2, DPMRX3 and DPMRX5, remove the two (2) counterweight support brackets and then rods and the install the round covers over the holes in the column.
<input type="checkbox"/>	For the DPMRX7, raise the head using an M8 Allen wrench, turn the Z-axis ballscrew at the top of the column to slowly raise the head. Remove the wood block that supports the head during shipment.
<input type="checkbox"/>	For the DPMRX7 remove the retaining plug that supports the counterweight located on the right side of the machine. The retaining plug supports the counterweight during shipping to prevent damage to the counterweight's chains and sprocket. Install the round cover over the hole in the column.
<input type="checkbox"/>	Remove the manual Z-axis hand crank and reinstall the lower way cover. (DPMRX3 & RX5 only)
<input type="checkbox"/>	Install (1) table tray on each end of the table (DPMRX5 only). Make sure to install the table trays on the proper side making sure the reliefs in the trays are facing the front and allow clearance to the gib locks.  Note – Make sure that the tray does not scrap the TURCITE. Check TURCITE for any damage.
<input type="checkbox"/>	For DPMRX7, install the 2 end covers on each end of the table.
<input type="checkbox"/>	Mount the pendant to the pendant arm using (4) M6-1.0x25 mm socket head cap screws along with flat and serrated lockwashers.
<input type="checkbox"/>	Connect the Ethernet cable and DB25 cable to the pendant.
<input type="checkbox"/>	Turn on power to the machine. The power switch is at the back of the electrical cabinet.
<input type="checkbox"/>	Lubricate all the way surfaces and the ball screws. Use service code 300.
<input type="checkbox"/>	Jog the table, saddle, and ram back and forth until the way surfaces are well lubricated. Oil should be visible on all the way surfaces.
<input type="checkbox"/>	Check the level of the machine. The machine should be level to within 0.0005" front to back and 0.0005" side to side. Even though it is the responsibility of the customer, make any adjustments if necessary.
<input type="checkbox"/>	Check tram on head and adjust as necessary.
<input type="checkbox"/>	Check to make sure that the E-Stop button is functioning correctly.
<input type="checkbox"/>	Check and adjust gibs as required.

<input type="checkbox"/>	Perform Service Code 11 to automatically calculate the backlash for the X and Y-axis of glass scale machines. Confirm they are within specification.
<input type="checkbox"/>	Confirm calibration is set properly by running our Repeatability programs. Check for positional accuracy and repeatability on the X, Y and Z-axis using programs XREPEAT.PT10, YREPEAT.PT10 and ZREPEAT.PT10 respectively. Positioning and repeatability values should be less than or = to 0.0005". Programs can be found on C drive in the SWI TEST PROGRAMS folder. If the calibration is out of specification, then perform Service Code 123 to calibrate the X, Y and Z-axis. If a user is installing the machine and you do not have a precision standard, cut part and measure and enter a calibration factor in service code 122.
<input type="checkbox"/>	Confirm the backlash compensation is set properly for each axis during the repeatability test above. If it is not, perform Service Code 128 to adjust the backlash for the X and Y-axis of single feedback machines (i.e. motor encoder only). This does not apply to glass scale machines.
<input type="checkbox"/>	Perform Service Code 123 and quill softkey to calibrate the Z-axis quill. If a user is installing a machine and you do not have a precision standard, cut part and measure and enter a calibration factor in service code 122.
<input type="checkbox"/>	Check that all other options that came with machine are installed and functioning correctly. The options are as follows: Limit switches, EHW's, Auxiliary Functions, Tableguards, Spraycool, Power Drawbar, Coolant pump, Worklamp, RSG.
<input type="checkbox"/>	For the power drawbar option, check to make sure that the tools load and unload properly. Verify the drawbar unit is sitting 0.050" to 0.075" above drawbar shoulder.
<input type="checkbox"/>	In high gear, confirm the spindle has been calibrated by checking with a Tachometer the spindle speeds at various RPM's. Check at 300, 1000, 2000, 3000, 4000 and 5000. At lower speeds the values should be within +/-5 RPM. At 3000 and above, the values should be within +/- 25 RPM.
<input type="checkbox"/>	Run the spindle at various speeds in both high and low gear for 15 minutes. Verify head shifts from high to low gear smoothly. Test quill feed and spindle brake.
<input type="checkbox"/>	Fasten all way covers.
<input type="checkbox"/>	Wipe down the machine prior to leaving.

## 2.15 Lubrication

### 2.15.1 Way Lubrication – DPMRX2, DPMRX3, DPMRX5, & DPMRX7

The auto lube system provides centralized automatic lubrication for the ways and ballscrews. The lube pumps 2-liter reservoir is serviced with ISO VG 68 / SAE 20W Slideway oil. The pump is factory set to pump oil for 15 seconds for every 60 minutes of axis motion and the discharge pressure is set to approximately 100-150 PSI.

Lube Pump Service Codes

Service Code	Title	Description
300	Lube Pump Discharge	This allows the user to manual discharge the lube pump.
301	Set Lube Pump Cycle Time	This sets the time in minutes between discharge cycles.
302	Set the Lube Pump Discharge Time	This sets the time in seconds for how long pump for each cycle.

To adjust the amount of Discharge Pressure displayed on the lube pump gauge, loosen the jam nut and turn the adjustment screw located on the top right side of the lube pump while the lube pump is activated.

At the beginning of each day, check the oil level in the Auto Lube system. If low, fill with ISO VG 68/SAE 20W Slideway oil.

When the ProtoTRAK control is turned on, the lube pump is cycled automatically to provide oil to the way surfaces.

**CAUTION!**

Allowing the Auto Lube to run dry may cause severe damage to the TRAK DPMRX2, DPMRX3, DPMRX5 and DPMRX7 way surfaces and ballscrews.

**2.15.2 Head Lubrication – TRAK Bed Mills**

This placard is included on the machine to remind the user of the maintenance schedule and how often the different maintenance activities need to be performed. Performing these activities at the recommended intervals will keep the machine running smoothly and avoid minor problems becoming major problems.

**MAINTENANCE SCHEDULE**

**DAILY**

- Remove majority of chips from around the axis slide ways, work table and way covers.
- Visually check lubrication pump oil level and make sure it is always above the minimum line. Fill with ISO VG68/SAE 20W.
- Add SAE 30 or 30W oil to the lower side cup on the head. This will provide lubrication to the quill.
- ❖ Empty chip tray.
- ❖ Visually check the coolant level and add if it is low.
- ❖ Visually check the air regulator pressure should be between 80 and 100 psi.
- ❖ Visually check power drawbar oil if low fill to 2/3 capacity.

**MONTHLY OR AS SPECIFIED**

- Cleanup any coolant accumulated on the bottom channel of the machine base.
- Visually inspect the condition of way and ballscrew covers. Clean if showing chip build up
- ❖ Every two months drain and remove the coolant and clean inside.
- ❖ Fill with new coolant.
- ❖ Replace filter on air regulator when pressure differential across the filter is 10 psi.
- Add 2 drops of SAE 30 oil to cup in front of head twice a month then move high low shifter up and down several times. **Do not add excess oil as it can damage the spindle bearings.**
- Apply two pumps of grade of general-purpose grease through grease fitting on the back of the head every 4 months.
- Check and adjust the gibs as needed every 6 months.

**YEARLY**

- Check backlash & belt tension on each axis and adjust if needed. Refer to the machine manual for more information.
- Inspect machine for any unusual wear and play.
- Check cables and pneumatic lines for any excessive abrasions or cuts.
- Please contact SWI Service Dept. for help with any machine maintenance procedures.  
Service Dept. contact number is 1-800-367-3165.
- ❖ When machine equipped with applicable option.

## 2.16 Machine Specifications

Note – The dimensions listed below are the maximum values, which comes with electrical handwheels.

MODEL NAME	DPMRX2	DPMRX3	DPMRX5
Table Size	49" x 9"	50" x 10"	50" x 12"
T-Slots (number x width x pitch)	3 x .63" x 2.5"	3 x .63" x 2.48"	3 x .63" x 2.52"
Travel (X, Y, Z axis) Note – for X axis (1st number is if user has Mechanical handwheel. 2 <sup>nd</sup> number if user has EHW). Lost ~ 1" of travel when moved to PT10 from PT5 due to motor bracket change	31.75/30.5 x 16 x 25.5"	31.5 x 17 x 25.81"	40 x 20 x 25.81"
Travel (X, Y, Z axis) with limit switches	~1" less on each axis	~1" less on each axis	~1" less on each axis
Quill Diameter	3 3/8"	3 15/16"	
Maximum Quill Travel	5"		
Spindle Taper	R8	40 Taper	
Spindle Speed Range	40-600, 300-5000		
Spindle Center to Column Face	18.5"	20.5"	20.5"
Spindle Motor Power	3 HP	5 HP	
Head Swivel (side to side)	+/- 90°		
Quill Feeds per Revolution of Spindle	0.0015/0.003/0.006"		
Power Requirements (volts, phase, current)	200-240V;3P;27A	200-240V;3P; 35A	
Maximum Weight of Workpiece	1320 lbs		1760 lbs
Height of Table from Bottom of Bed	36.75"	36.75"	40"
Max Spindle Nose to Table	25.5"	25.81"	25.81"
Min Height	86.625"	87.5"	87.5"
Max Height	98.75"	100.5"	102"
Width of machine including table	71.25"	73.5"	94.13"
Length with electric box door closed	73.31"	76.63"	82.5"
Overall width including full table traverse	102.53"	102.25"	131.06"
Overall length with electrical door open	93.88"	96.63"	103"
Footprint of Machine	23.13" x 40.5"	24" x 43.31"	24" x 48.4"
Weight Net / Shipping Lbs.	3200 / 3500	4100 / 4400	4400 / 4700
Rapid Traverse X, Y, Z	250 ipm on X, Y and Z with Mechanical Handwheels 400 ipm on X and Y 250 ipm on Z on EHW machines		400 ipm on X and Y 250 ipm on Z
Coolant Capacity	10 gallons		

### Maximum Work Capacities in Mild Steel

Drilling Max Capacity	1"		
Milling Max Capacity	3 inch <sup>3</sup> /min	5 inch <sup>3</sup> /min	
Tapping Max Capacity	3 / 4 – 10"	1 – 8"	

<b>MODEL NAME</b>	<b>DPMRX7</b>
Table Size	76" x 14"
T-Slots (number x width x pitch)	4 x 16mm x 63.5 mm
Travel (X, Y, Z axis)	60" x 23" x 24.25"
Travel (X, Y, Z axis) with limit switches	~1" less on each axis
Quill Diameter	4.56"
Maximum Quill Travel	5.5"
Spindle Taper	40 Taper
Spindle Speed Range RPM	40-600, 300-5000
Spindle Center to Column Face	24"
Spindle Motor Power	7.5 HP
Head Swivel (side to side)	+30° CW and -90° CCW**
** Head swivel is limited to approximately 30° in the clockwise direction due to the pendant arm extension bracket.	
Quill Feeds Per Revolution of Spindle	0.0015/0.003/0.006"
Power requirements (volts, phase, current)	200-240V / 3P / 42A
Current (Full load Amp)	42 FLA
Maximum Weight of Workpiece	2200 lbs.
Height of table from bottom of bed	38.75"
Max spindle nose to table	24.25"
Min height	87.875"
Max height	105"
Width of machine including table	110"
Length with electric box door closed	94.5"
Overall width including full table traverse	168.5"
Overall length with electrical door open	119"
Footprint of Machine	42.52" x 63"
Weight net / shipping lbs.	7480 / 7700
Rapid Traverse X, Y, Z	400 IPM on X and Y 250 IPM on Z
Coolant Capacity	15 gallons

### Maximum Work Capacities in Mild Steel

Drilling Max Capacity	1" dia.
Milling Max Capacity	7 inch <sup>3</sup> /min
Tapping Max Capacity	1-8"

## 2.17 ProtoTRAK RMX Euclid Block Procedure

The test part should be machined at the completion of the installation.

The material for the Euclid block test part is found in the toolbox.

- Material Specification: Aluminum, 6061-T6 or T4
  - Blank Size: (minimum dimensions) 3 x 3 x 1", provided in tool box
  - Tool: .750 end mill, 2 flute, high speed steel, sharp
  - Coolant: Flood coolant, Cool-Tool or Kerosene
1. Mount vise and indicate the back jaw parallel to the table within .0005".
  2. Clamp material in vice with a minimum of .800" above the vise jaws.

3. Load in the Euclid block program, it is part number euclid.PT10. It is found under the C drive, PROTOTRAK folder, followed by the SWI TEST PROGRAMS folder.
4. Use an edge finder to set Absolute 0 on X and Y. Absolute zero is the front left corner of the block as viewed from in front of the machine.
5. Load the .750 end mill and set Z Absolute 0 at the top of the part, and set Z reference positions in the SET UP mode. Set Z-retract a few inches above the part.
6. Set up tool table
7. Begin to run the program. The part will be machined in the following sequence
8. After the program run, the program will locate to the following position.
  - X = 1.318
  - Y = 1.318

Event(s) #	Description	Depth of Cut
1	circle pocket – cuts middle circle	-0.250"
2-7	circle frame – cuts outer 1.830 diameter circle	-0.250"
8	circle frame – cuts material from corners remaining on Euclid block cuts triangle on Euclid block	-0.250"
9-25	rectangular frame – cuts outer 2.750" rectangle	-0.500"
26		-0.7500"

9. Mount a dial indicator in the quill and check the circles.
10. Check the runout of the sides of the square frame.
11. Inspect the machined surfaces for smoothness.

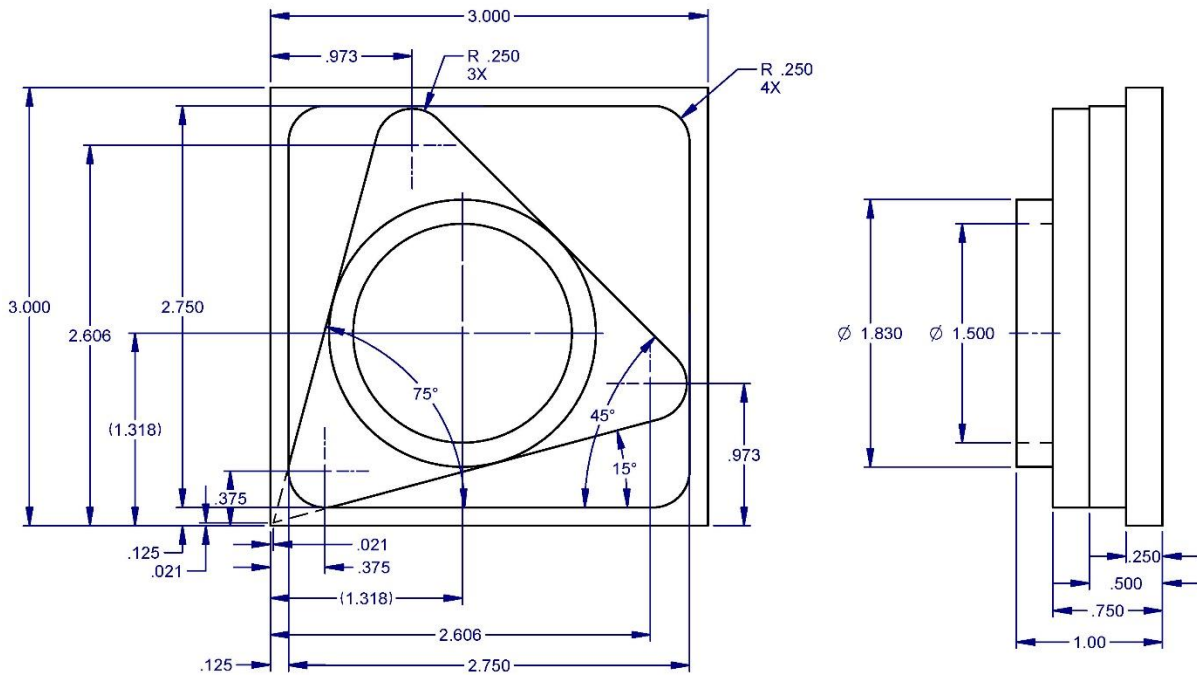

i15537-1

## 3.0 Troubleshooting by Symptom

Use this section to begin the process of resolving a service problem. Each symptom type is described in a few words and then more fully described in an explanatory paragraph. Following this is a chart that directs in the most logical steps.

**FOR ADDITIONAL DETAILED TROUBLESHOOTING PROCEDURES, PLEASE VISIT OUR DOZUKI WEBSITE:**

<https://trakmtsupport.dozuki.com/>

### 3.1 Problems Relating to Machining Results

#### 3.1.1 Poor Finish

The part finish is marred with scallops or is very rough.

Do the following Service Codes and document values:

- **Code 33** Software Identification. This is needed if you call SWI Customer Service.
- **Code 11** Measures backlash in the system (Only used on Dual Feedback systems)
- **Code 128** Enter backlash compensation (for Z-axis on three-axis systems; not used on Dual Feedback systems)

Possible Cause	Check This
Too much backlash entered for code 128 or calculated with code 11.	Verify nothing is mechanically loose and the backlash values are not higher than what physically is in the system.
Machine Tool & Setup problem	Check for any looseness in the setup (Tool, Tool holder, Part, Vise, or Fixture). Check the condition and type of cutter being used, type of material, RPM and Feedrate, etc.
Table, Saddle, or Ram Locks are locked	Make sure the Table and Saddle Locks are unlocked. Never use gib locks with a CNC machine.
Inadequate or no Lubrication to Ballscrews and Way surfaces	Make sure all the Way surfaces are getting proper lubrication. If not, check to make sure that the lube pump is functioning properly. Also check for any pinched or blocked oil lines.
X, Y, and Z Gibs are not adjusted properly	Check the adjustment of the X and Y gibs. See X and Y Gib Adjustments in Section 5.1.
X & Y-axis Drive Trains are loose	Check Repeatability using the Repeatability and Positional Accuracy procedure. Step by step, carefully inspect the Drive Train for any looseness. It may be necessary to disassemble and then reassemble the Drive Train.
Way surfaces are pocked, scarred, or excessively worn	Visually check the condition of all the Way surfaces. For machines that may have excessively worn Way surfaces you may need to adjust the Gibs in this area. This will affect performance when using the machine outside of this area. Check lubrication to affected areas.



### 3.1.2 Circles Out of Round

Circles are not round within 0.002" TIR over 3.0" DIA. This is best measured by placing a dial indicator in the quill and sweeping around the part.

Note – The typical slideway-milling machine is not capable of achieving more precise results although careful adjustments to a new milling machine may produce better results. If more precise circles are required, then it is recommended to use a precision boring head/boring bar.

Do the following Service Codes and document values:

- **Code 33** Software Identification. This is needed if you call SWI Customer Service.
- **Code 11** Measures backlash in the system (Only used on Dual Feedback systems)
- **Code 128** Enter backlash compensation.

Possible Cause	Check This
Torque values on X and Y-axis are too high.	Make sure torque is lower than 20 in-lbs. Normal values for a machine that is aligned and adjusted properly should be between 10 and 15 in-lbs. Make sure torque is consistent across axis travel.
Machine Tool & Setup problem	Check for any looseness in the setup (Tool, Tool holder, Part, Vise, or Fixture).
Machine not level	Verify that the machine is level to specification.
Head is not Trammed	Verify that the Head is Trammed to specification. See <a href="#">Tramming the Head Sec 5.2.2</a>
X, Y, and Z Gibs are not adjusted properly	Check the adjustment of the X and Y Gibs using the X and Y Gib adjustment procedures.
Calibration or Backlash problem	Recalibrate the machine. Reset the Backlash. Check <a href="#">Repeatability and Positional Accuracy</a> .
Glass Scale problem	Make sure that the Glass Scale is installed correctly according to the Glass Scale Installation procedures. Check for any loose brackets or misalignment etc. Also, check to make sure the Glass Scale assemblies are functioning correctly.
X & Y-axis Drive Trains are loose	Check Repeatability using the Repeatability and Positional Accuracy procedure. Step by step, carefully inspect the Drive Train for any looseness. It may be necessary to disassemble and then reassemble the Drive Train.
Head Bolts are loose	Verify that all the head bolts are tight. Torque to 50 ft-lbs.

## 3.2 Problems Regarding the Motion of the Machine

### 3.2.1 Run Away Axis

The axis makes an unwanted move at rapid speed in one direction and faults out. This is usually caused by an encoder signal being interrupted.

Do the following Service Codes:

- **Code 33** Software Identification. This is needed if you call SWI Customer Service.
- **Code 131** Manual DRO – Turn mechanical handwheels or ballscrew to check motor encoder counts vs glass scale counts.

Possible Cause	Check This
Motor encoder versus glass scale encoders are counting in opposite directions	This would be apparent during a new install or when a pendant/computer module is replaced. Run service code 131 to confirm this is your problem. If it is your problem run services codes 322 for the X axis or 321 for Y axis. The will reverse the glass scale directions.
The home positions or tools are not set correctly and hence the machine moves to location that is surprising to the operator.	See the Controls Programming, Operations and Care manual.
The Glass Scale is not reading.	Turn off glass scale and see if faulting goes away
Bad Motor Encoder	Run service code 131. If the motor is not counting, check the connections at the motor and to the servo drive in the electrical cabinet.
Motor has failed	Swap motor with other axis and replace motor as necessary.

### 3.2.2 Axis Will Not Jog

The system powers up but will not respond to the jog command. Generally, when this happens, you will see a fault on one of the axis.

Do the following Service Codes and procedures:

- **Code 33** Software Identification. This is needed if you call SWI Customer Service.
- **Code 131** Manual DRO – turn mechanical handwheels or ballscrew to check motor encoder counts vs glass scale counts.

Possible Cause	Check This
The power reset button on run panel has not been pressed	This would be apparent during a new install or when a pendant/computer module is replaced. Run service code 131 to confirm this is your problem. If it is your problem run services codes 322 for the X axis or 321 for Y axis. The will reverse the glass scale directions.
E-Stop is pressed in	See the Controls Programming, Operations and Care manual.
Servo Drive failure	Turn off glass scale and see if faulting goes away
Motor has failed	Swap motor with other axis and replace motor as necessary
Poor cable or wiring connections	Check all Electrical Connection
Computer Module failed	If the motor appears good and you have power, then the computer module may need to be replaced.

## 3.3 Problems Relating to the Operation of the Control

### 3.3.1 Fault X or Y or Z

The program run or jogging operation is interrupted with a Fault Message on the display.

Do the following Service Codes and procedures:

- **Code 33** Software Identification. This is needed if you call SWI Customer Service.
- **Code 131** Manual DRO – turn mechanical handwheels or ballscrew to check motor encoder counts vs glass scale counts.

Possible Cause	Check This
Motor encoder versus glass scale encoders are counting in opposite directions	This would be apparent during a new install or when a pendant/computer module is replaced. Run service code 131 or 100 to confirm this is your problem. If it is your problem run services codes 322 for the X axis or 321 for Y axis.
Cable connection problems	Check all cable connections.
Table and Saddle Locks are locked	Make sure the Table and Saddle Locks are unlocked. High torque on any axis may cause faulting problems.
X and Y Gibs are adjusted extremely tight	Check the adjustment of the X and Y Gibs using the X and Y Gib adjustment procedures.
Binding or looseness in the Drive Train	Inspect drive trains
Incoming electrical power	Incoming voltage too low. Should be 200 to 240 volts.
Motor encoder or glass scale not working properly	Run service code 131. Turn off glass scales with service code 304 and see if fault goes away.
Motor or Servo Drive failure	Swap motor from one axis to another and see if problem stays or follows motor.
Computer module failure	If problem does not follow motor, then replace computer module.

### 3.3.2 Pendant Does Not Respond & Appears to be Locked Up

The pendant is not responding to any key presses.

Symptom	Troubleshooting Procedure & Possible Causes
1	No Beep when any button is pressed or touch screen is pressed
2	Screen does not change when touched
3	USB Keyboard does NOT respond.
4	Pressing E-stop Stops the axis but Pendant does not change screen.
5	Numeric Key press does produce the Key Press LED to turn ON.
6	Removing Computer module Network does not change Lock-up condition.
Solution	Reboot control and see if problem goes away. If it does, continue to run and see what happens. If the problem comes back, then replace the Pendant Module.

### 3.3.3 USB Not Working on Pendant

When plugging in a USB device, the control does not recognize it.

Symptom	Troubleshooting Procedure & Possible Causes
	Device driver not installed for USB device. Run service code 540 and load USB driver. One single USB or all USB connections are not working with any device.
Solution	Reboot control and see if problem goes away. If it does, continue to run and see what happens. If the problem comes back, then replace the Pendant Module.

### 3.3.4 Pendant Does Not Power On

When you see this symptom, we need to make sure power is getting to the pendant from the computer module.

Steps to Troubleshoot:

1. Verify the DB25 pin connector and Computer Module Ethernet cable is connected.
2. Verify 24 VDC is making it to the pendant. Check LED on back of pendant. If no LED, then the computer module is probably the problem. Make sure the computer module is getting power. If it is, then the computer module is the likely problem.
3. If 24 volts reaches the pendant, then verify the 12 VDC and 5 VDC LED's are on. If they are not, there is a failure in the pendant. Open pendant and check connections. If they are good, replace pendant module.

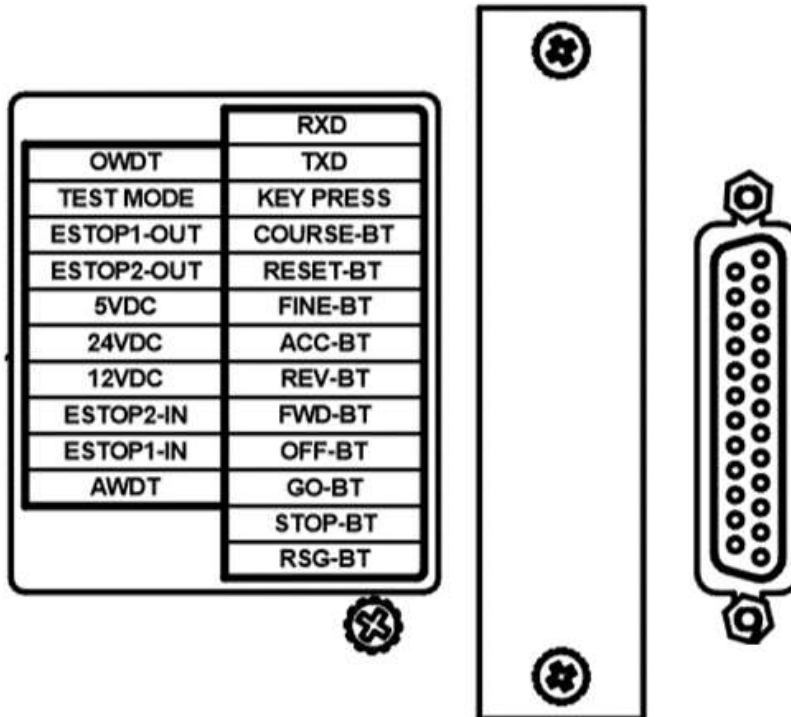

**Figure 3.3.4 – DB25 Connector Pinout and LEDs for RMX Control**

## 4.0 Service Codes

These are the most commonly used service codes for the TRAK DPM RX Bed Mills.

Code Number	Title	Description
1	Program, Configuration File, Log Back up	The following service code captures all important data from the RX machine. This includes the user's program, master and slave configuration files, master and slave message logs, master and slave fault logs etc. This is meant to be used to help us solve problems that may pertain to our software. This file can then be emailed to our service department. The files are saved to a Zip file.
33	Software, Firmware and PLC versions	Displays current software versions, master and slave operating system versions, machine ID key and software option versions.
123	Calibration Mode	Use to calibrate the RMX control with a standard. Note – when you have glass scale option, we calibrate both the motor and glass scale at the same time.
128	Backlash Calibration Constant	Use to load backlash compensation for each axis.
141	Load configuration file from USB thumb drive	To load configuration files from a USB thumb drive to the RX control.
142	Save configuration file to USB thumb drive	To save the configuration files for reloading later. When a computer replacement is necessary, saving the settings to a thumb drive for reloading them later is highly desirable.
300	Lube Pump Switch Discharge	Allows the user to manual discharge the lube pump
301	Set Lube Pump Cycle Time	Sets the time in minutes between pumping cycles
302	Set Lube Pump Discharge Time	Sets the time in seconds for how long to pump for each cycle.
316	Update Software	Runs the routine that copies new software from a USB thumb drive device to the ProtoTRAK system. Use this routine to install new ProtoTRAK software.
318	Converter and Software Options	Displays which software options are turned on. Options in bold letters mean the option is active.

## 5.0 Procedure for Replacements & Maintenance

### 5.1 Replacements

#### 5.1.1 Brushless Motor Replacement

**WARNING!**

Do not work with the brushless motors unless the power is disconnected from the machine. The motors are run by 220 VAC. There is possibility of death by electrocution!

1. Turn off power to the machine.
2. Each X or Y motor (0.75 KW for the RX2, 3 and 5 and 1 KW for the RX7) is mounted by the use of (4) ¼-20 cap screws. The Z axis motor (1 KW) is mounted by the use of (4) M8-25 screws. Be careful not to over- tighten these bolts and strip the threads.

**WARNING!**

Do not remove the Servo Drives unless the power is disconnected from the machine. The servo drives are run by 220 VAC. There is possibility of death by electrocution!

#### 5.1.2 Servo Drive Replacement

The servo drive for each axis is mounted in the electrical cabinet using (2) M5-30 cap screws.

**DANGER!**

Always engage (push in) the Emergency Stop switch, turn the ProtoTRAK RM Control off, and disconnect the servo motor/driver cable at the cable breakout box.

1. Press in the Emergency Stop.
2. Remove power from the machine.
3. Disconnect the two digital cables with DB connectors (CN1 and CN2).
4. Disconnect the incoming motor power 8 individual wires with lug termination from the drive (labelled L1-6, L2-6, L1-7, L2-8, L3-7, U, V, W). Do not pull on the wires.
5. Remove the green ground wire by removing the green screw on the bottom left corner of the unit.
6. Mount the new servo drive in the cabinet. The servo drive is programmed for either X, Y or Z axis.
7. Reconnect the green ground wire followed by the two digital cables and 8 power wires.



**Figure 22 – Servo Drive & Motor Replacement**

<b>P/N</b>	<b>Description</b>
28164	Motor-Brushless-Delta-750W (RX2/3/5: X & Y Axes)
28164-1	Motor-Brushless-Delta-1KW (RX2/3/5 Z Axis & RX7 All Axes)
29980-DPMRX2-X	RX2 Servo Drive – Delta – Programmed – RX-750W
29980-DPMRX2-Y	RX2 Servo Drive – Delta – Programmed – RX-750W
29980-DPMRX2-Z	RX2 Servo Drive – Delta – Programmed – RX-1KW
29980-DPMRX3-X	RX3 Servo Drive – Delta – Programmed – RX-750W
29980-DPMRX3-Y	RX3 Servo Drive – Delta – Programmed – RX-750W
29980-DPMRX3-Z	RX3 Servo Drive – Delta – Programmed – RX-1KW
29980-DPMRX5-X	RX5 Servo Drive – Delta – Programmed – RX-750W
29980-DPMRX5-Y	RX5 Servo Drive – Delta – Programmed – RX-750W
29980-DPMRX5-Z	RX5 Servo Drive – Delta – Programmed – RX-1KW
29980-DPMRX7-X	RX7 Servo Drive – Delta – Programmed – RX-1KW
29980-DPMRX7-Y	RX7 Servo Drive – Delta – Programmed – RX-1KW
29980-DPMRX7-Z	RX7 Servo Drive – Delta – Programmed – RX-1KW

### **5.1.3 Pendant and Computer Module Replacement**

#### **5.1.3.1 Pendant Replacement**

1. Turn power off to the machine and control.
2. Unplug all the connectors on the pendant arm side of the pendant.
3. Remove the pendant from the pendant arm by removing the (4) M6-1.0x25 25B screws that secure it in place.
4. Mount the replacement pendant on the arm with the (4) mounting screws.
5. Reconnect all the previously removed cable connections.

### 5.1.3.2 Computer Module Replacement

1. Turn power off to the machine and control.
2. Unplug all the connectors connected to the Computer Module.
3. Remove the Computer Module from the Electric Box by removing the (6) M5-0.8x12 SHCS that secure it in place.
4. Replace the Computer Module and reinstall by mounting with the screws used to mount the previous unit.

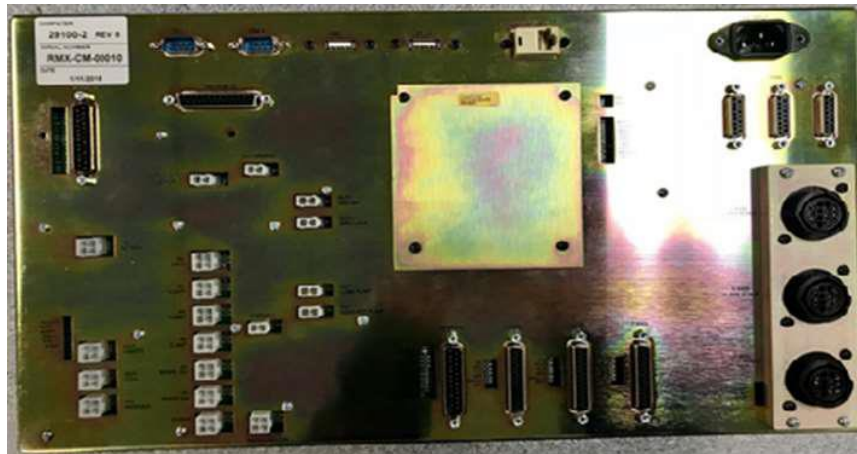

**Figure 23 – Pendant & Computer Module Replacement**

Item	P/N	Description
1	29006-1	RMX PENDANT
2	29100-2	RMX COMPUTER MODULE



#### 5.1.4 Updating the Pendant and CM Software

1. On the pendant, touch the "Status" soft key on the upper left portion of the touch screen. This will display the pendant and CM software version.
2. To verify the current software versions, go to <https://www.southwesternindustries.com/software>
  - Click on the "Current ProtoTRAK CNCs Software" tag. Find the RX section and refer to the software versions list.
3. To update to a more current version, first download the software from the website onto a USB Flash Drive.
4. Plug the USB Flash Drive into one of the pendant USB ports.
5. On the Pendant, select the soft key "Service Codes". Type in "316" and press the ABS Set key. Follow the instructions on the screen.

**Note** – Your configuration/calibration settings will not be changed by this procedure.

If you wish to store your settings on a USB Flash drive, install a drive in one of the ports and use Service Code 142 to save the values. Service Code 141 can be used to restore the values on your Flash Drive back onto the pendant.

#### 5.1.5 Cable Routing on Machine

Whenever you replace a cable or reroute a cable it is very important to keep the power cables and logic cables separated from each other. The power cables consist of the (3) 220-volt motor cables and (2) 220-volt power cables for the Computer Module and a coolant pump or lube pump cable. The logic cables are used to carry encoder signals between the servos and computer module. Mixing of the power and logic cables may cause noise from the power cables to interrupt the signals in the logic cables. This can lead to intermittent axis faults or repeatability problems.

#### 5.1.6 Glass Scale Replacement

##### 5.1.6.1 Remove the X, Y, or Z Glass Scale

1. Unplug the glass scale circular style connector connected to the Computer Module in the Electric Box.
2. Unbolt the reader head of the glass scale from its mounting surface.
3. Unbolt the glass scale enclosure from the table on X or the mounting spar on Y.
4. Install the head alignment bracket that came with the replacement scale to this scale to secure it for shipping back to SWI. Failure to do this may cause the glass scale to get damaged during shipment. The head alignment bracket secures the reader head so it cannot move and damage the glass in the scale.

**Note:** *1<sup>st</sup> align the reader head on the new scale before removing it to fasten the old scale.*

#### **CAUTION!**

Once the head alignment bracket is installed, do not traverse the axis or the reader head will break.

##### 5.1.6.2 Install the X or Y Replacement Scale

1. Mount the scale to the back of the table or Y-axis mounting spar.
2. Align the scale so that it is within +/- 0.005" end to end.

**CAUTION!**

If the scale is not long enough for the table, it will break when the machine is traversed past the scale travel.

**Note:** For the Y-axis, the mounting spar should already be aligned. It must be parallel to the Y-axis travel within +/- .005" end to end both horizontally and vertically. The mounting spar can be aligned in and out by the use of the adjustment screw.

3. Line the reader head up with the mounting holes on the back of the saddle for the X-axis or the bracket on the Y-axis.
4. Install the reader head bolts but leave them loose.
5. Use the jackscrews on the reader head to compensate for some gap between the reader head and the reader head mounting bracket. Leave the alignment brackets attached to the reader head. This bracket assures the reader head is aligned to the glass scale.
6. Tighten each jackscrew until it touches the bracket and then back it off 0.001" or 0.002". Use a feeler gage to set the gap.
7. Tightening the reader head mounting screws. This ensures the reader head is aligned within a few thousandths.
8. Remove the shipping bracket that fixes the reader head to the scale for shipping.

**WARNING!**

After the reader head is attached to the reader head mounting bracket, do not move the machine axis until the shipping bracket is removed. This will break the reader head. This is not covered under warranty.

(See figure 30 for illustration of how to align glass scales.)

**5.1.6.3 Installing the Z Axis Glass Scale (See Replacement Chart)**

1. Check the tram of the head in the X direction. If it is within a few thousands then continue on otherwise tram.

Chart A: Glass Scale Part Numbers

<b>Machine</b>	<b>HeidenHain/Accurite Glass Scale Replacements (SWI)</b>
<b>DPMRX2</b>	
X Axis	22800-35
Y Axis	22800-16
Z Axis	22800-4
<b>DPMRX3</b>	
X Axis	22800-35
Y Axis	22800-16
Z Axis	22800-4
<b>DPMRX5</b>	
X Axis	22800-42
Y Axis	22800-24
Z Axis	22800-4
<b>DPMRX7</b>	
X Axis	22800-60
Y Axis	22800-24
Z Axis	22800-4

### 5.1.7 Power Drawbar

A power drawbar is an optional item on the DPMRX machine. It is bolted to the top of the head by the use of 3 SHCS. Some machines may require a washer to space the unit up to the proper height to allow the drawbar to engage properly. The power drawbar unit must be mounted at the correct height to prevent damage to the drawbar.

**Air Regulator and Oiler** – This unit requires between 80 and 100 psi to operate properly. Some units work fine at 80 psi while others may need 90 or 100 psi. It is also important to make sure the oiler for this unit is kept filled with oil. Fill the reservoir about 2/3 full using AIR TOOL OIL ONLY. Failure to do this will not allow oil to lubricate the internal components of the unit and it may wear out prematurely. It is also important to make sure the oiler is set properly. To set the oiler, first close the adjustment screw (CW) on top of the oiler completely making sure to not over tighten. Then open the screw (CCW) between 1/2 to 3/4 of a turn. Any more than this will cause too much oil to get into the unit and oil may come out of the exhaust port of the unit.

**Tool Alignment Device** – This unit also comes with a tool alignment device, which attaches to the bottom of the spindle. This device allows the tool to easily be aligned with the dogs when loading a tool.

#### CAUTION!

Some tools may not work with this device and the original spindle dogs will need to be used. The original spindle dogs are shipped with each machine in the toolbox. Some boring bar holders may not work with this device.

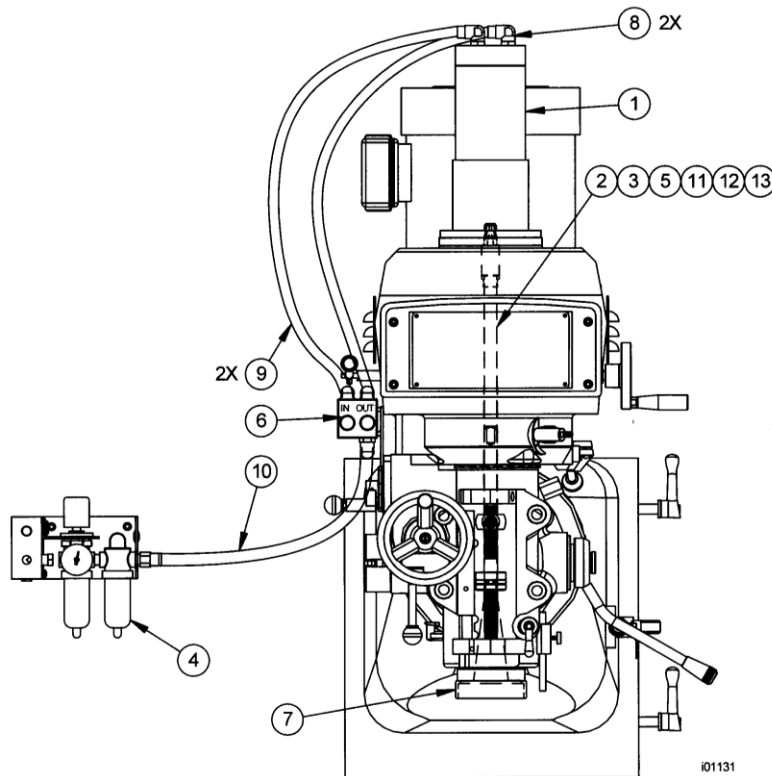

**Figure 37 – Power Drawbar Assy – DPMRX2, DPMRX3, DPMRX5**

**Parts List: Power Drawbar Assy – DPMRX2, DPMRX3, DPMRX5 (Figure 37)**

<b>Item</b>	<b>P/N</b>	<b>Description</b>
1	22581-1	AIR GUN ASSY ONLY- TORQUE RITE
2	26987	DRAWBAR-R8 SPINDLE WITH SPACER
4	22380-1	AIR REGULATOR ASSY (with solenoid if with Aux Function)
5	29616	SPACER - DRAWBAR
6	22581-2	SWITCH - CONTROL HEAD - TORQUE RITE
7	22581-4	NOSEPIECE FOR SPINDLE
8		1/4" NPT AIR FITTING 90°
9		3/8 O.D. TUBING 132" LG.
10		3/8 O.D. TUBING 27" LG.
11	29615-NMTB	DRAWBAR - NMTB -40 TAPER SPACER 29616
12	24165-CAT	DRAWBAR - CAT - 40 TAPER SPACER 29616
13	TR220	SOCKET - AIR GUN REPLACEMENT (not shown on drawing)
14	K010001	MUFFLER-DRAW BAR (not shown on drawing)

**Parts List: Power Drawbar Assy – DPMRX7**

<b>Item</b>	<b>P/N</b>	<b>Description</b>
1	29615-CAT	Drawbar DPM7 CAT: Includes Spacer
2	29615-NMTB	Drawbar DPM7 NMTB: Includes Spacer

**5.1.8 Wiring of the Auxiliary Output Function**

The Auxiliary Output is a Normally Open (NO) contact and rated for 30 volts DC or AC and up to 1 amp, via terminals TB52-NO-1 and TB53-NO-2.

The Auxiliary Output relay is overwritten by the E-stop and/or Fault circuit which will deactivate the relay whenever there is an E-stop condition or when the software shuts OFF all the outputs due to a fault condition.

The Auxiliary output feature also provides 24 volts, via the above terminal blocks TB54-24DC and TB55-0DC. This Auxiliary power can be used to power a 24V Relay/Solenoid or other device through this Auxiliary Output. It is rated for 1 amp.

The Air Blast Solenoid example below uses the Auxiliary 24V and will be turned OFF and ON via the Auxiliary Output when programmed with the AUX event.

As shown in Figure 38, there are two cables which connect from the Electrical Box DIN Rail positions TB50-T52 and TB53-TB56 and connect to the Computer Module 4-contact connectors labelled "I/O AUX" and "OUT-24DC" respectively.

See the Programming Manual (P/N 29603) to see how to program the Aux Functions. The manual is available for download at [https://www.southwesternindustries.com/media/manuals/29603\\_manual.pdf](https://www.southwesternindustries.com/media/manuals/29603_manual.pdf)

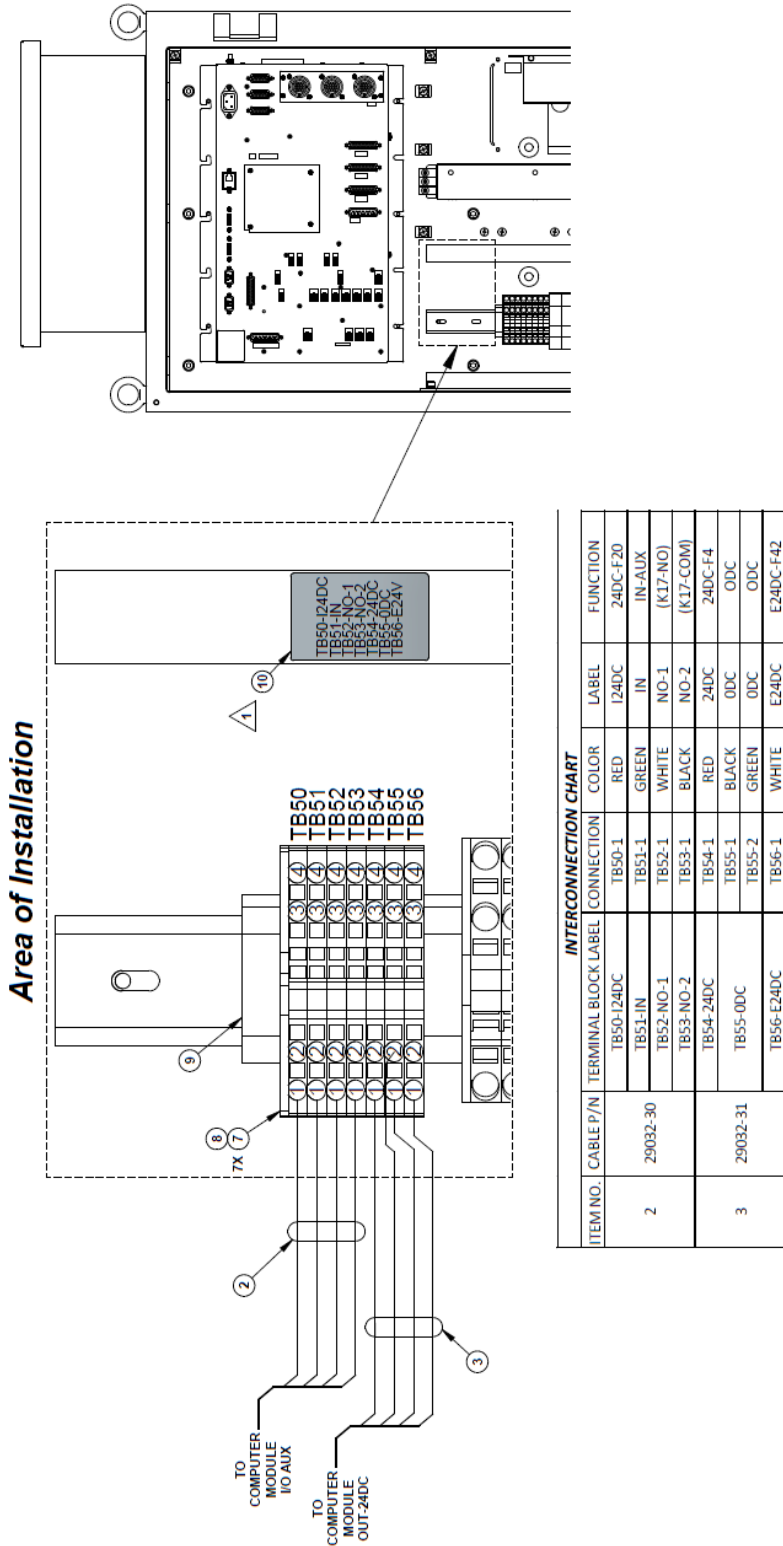

**Figure 38 – Auxiliary Function Wiring**

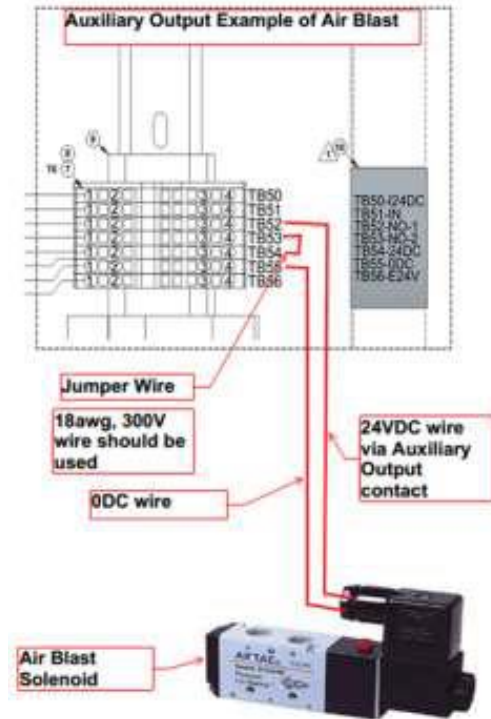

**Figure 38A – Wiring Example of Auxiliary Output Feature**

### 5.1.9 Air Solenoid Replacement for Power Drawbar with Aux Function Spray Cool

1. Unhook the air from the machine.
2. Unplug the power cable that connects to the right side of the air regulator bracket.
3. Remove the 2 screws that hold the connector to the bracket.
4. Undo the airline that runs from the oiler to the power drawbar if that option is installed on the machine.
5. Remove the 2 screws on the left side of the bracket that holds the air manifold to the U-shaped bracket.
6. With the assembly in hand unthread the solenoid from the rear of the air regulator. The solenoid and cable will be replaced as a unit.

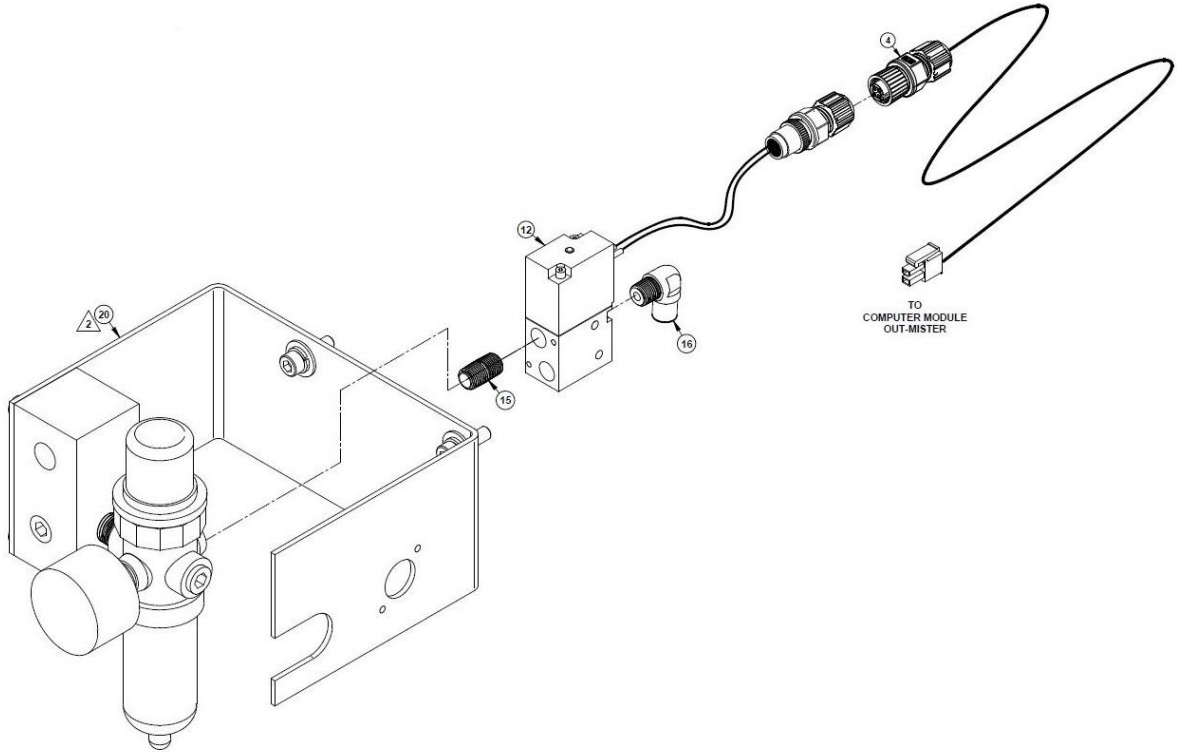

△ AIR REGULATOR ASSY (ITEM 20) MAY BE RETURNED TO STOCK IF POWER DRAWBAR OR SPRAY COOL IS ALSO ORDERED.

Item	P/N	Description	Qty
12	22772-1	SOLENOID ASSY-24VDC	1
20	22380-2	AIR REGULATOR ASSY-S SERIES-FILTER	1

### 5.1.10 Electronic Handwheels

The handwheels are mounted on the machine by the use of 4 SHCS. The X and Y hand wheel have a hole in the hand wheel so the mounting bolts can be accessed easily with a 5 mm Allen wrench or ball end screwdriver. The handwheels are plugged into the Computer Module on the upper right section in the electrical cabinet.

Machine	Axis	Electronic Handwheel Part Number
RX2, RX3, RX5 and RX7	X & Y	21946 or 21946R (refurbished)

### 5.1.11 Spindle Motor Wiring

The DPMSX spindle motors are wired for 220 volts.  
(See Figure 55 on how to wire the motor.)

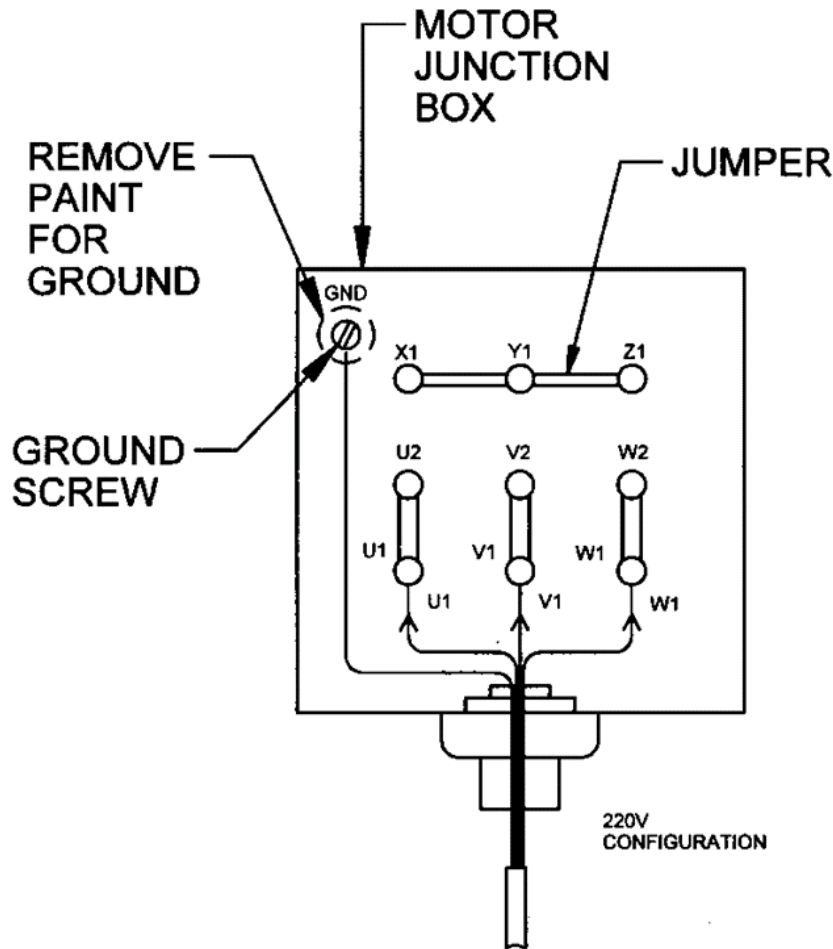

**Figure 55 – Spindle Motor Wiring**

### 5.1.12 Feed Trip Adjustment

If the feed trip is adjusted too light it will inadvertently trip when drilling. If too heavy, it will not trip accurately and stress the mechanism. The correct adjustment depends on the operation to be performed.

To adjust:

1. Release the lock nut.
2. Engage the trip handle – move it left.
3. Adjust the micrometer nut against the quill stop knob.
4. Slowly turn the adjusting screw until the handle trips.
5. Tighten the lock nut.
6. Check the reaction. If too sensitive, lower the adjusting screw slightly. If too heavy, raise it.



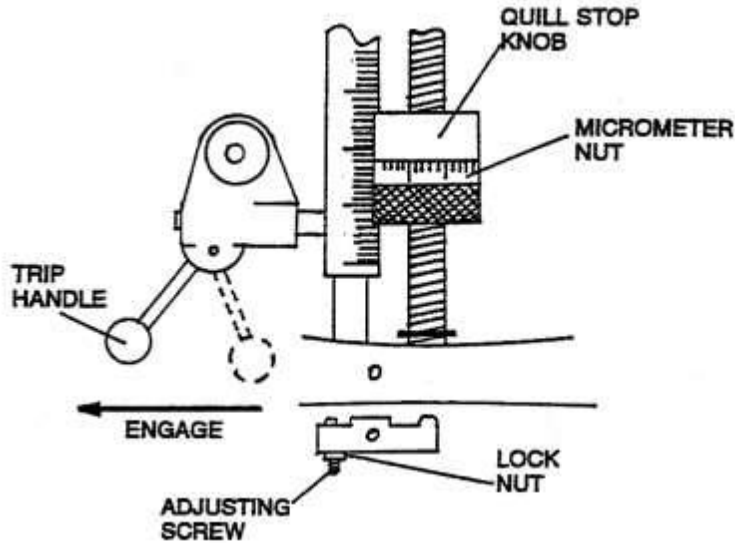

i00153

**Figure 56**

### 5.1.13 Quill Clock Spring Replacement and Adjustment

The Quill Clock Spring counterbalances the weight of the quill and tool.

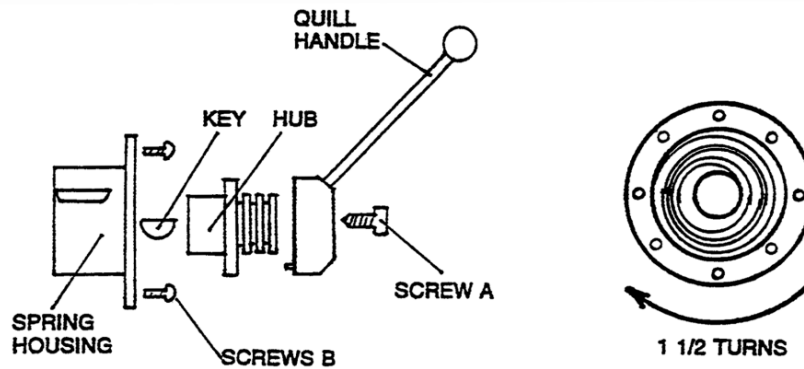

**Figure 57**

1. Move the quill to its top position and lock it in place.
2. Remove the quill handle, hub (by removing Screw A) and key.
3. Remove Screws B and allow the spring housing to unwind.
4. Remove the spring. It is held by a pin on the shaft and slot in the housing.
5. Replace the spring. Rotate the housing clockwise until the spring catches the shaft pin.
6. Rotate (wind up) the housing 1 1/2 turns, replace Screws B, key hub, Screw A, and handle.

#### **5.1.14 Spindle Motor Removal and Replacement: DPMRX2, DPMRX3, DPMRX5, & DPMRX7**

**CAUTION!**

The motor is heavy – about 120 pounds. Be certain you have the proper equipment or assistance.

1. Turn machine off. Disconnect power from machine.
2. Remove the spindle head cover to gain access to the spindle motor.
3. Open motor junction box and disconnect all wires and conduit from motor. Take note how the motor is wired and re-wire in the low voltage configuration.
4. Release the belt tensioning device that is used to tight the belt.
5. Remove the 4 screws that hold the motor down in place.
6. Slide the motor forward to remove the belt from the motor pulley.
7. Remove the motor. Be careful, the motor weighs over 120 lbs. Use a lift to remove the motor and to put the new motor in place.
8. Slid the belt over the motor pulley and snug the 4 bolts that fastens the motor down.
9. Tension the belt by use the belt tensioning device in front of the motor. Be careful not to over tighten the belt. The belt should deflect about ¼" in the center of the belt when applying force in this spot.
10. Tighten the 4 bolts that hold the motor down.
11. Connect all wires and the conduit back to the motor junction box.
12. Install the head cover plate and turn power back on to the machine.

#### **5.1.15 Spindle Drive Belt Replacement: DPMRX2, DPMRX3, DPMRX5, & DPMRX7**

1. Remove the motor.
2. Remove the draw bar and its bushing and Power Drawbar unit installed.
3. Remove the three screw, M6 x 35mm, on the top bearing cap. Place the 2 screws in the adjacent tapped holes to be used as a jack in order to remove the Bearing Cap.
4. Remove six SHCS around the bottom, holding the belt housing to the subplate.
5. Remove the belt housing.
6. Placed new belt over front pulley.
7. Reassemble in reverse order for instructions above.
8. Snug the 6 SHCS securing the bearing housing to the subplate. Install the bearing cap with the same 6 screws.
9. Re-install the motor with the belt around the pulley and tension.
10. With the quill in the fully up position and the speed shifter in the High position, run the motor and adjust the alignment of the belt housing and bearing cap to eliminate any vibration and noise. Tighten all SHCS in a star pattern.
11. Reset the belt tension.

#### **5.1.15.1 Axis Drive Belts Replacement: X-Axis DPMRX2, DPMRX3**

1. Remove the end table.
2. Remove the belt cover.
3. Loosen motor.
4. Remove and replace belt.
5. Reassemble in reverse order.

#### **5.1.15.2 Axis Drive Belts Replacement: X-Axis DPMRX5, DPMRX7**

1. Remove the belt cover.
2. Loosen motor.
3. Remove and replace belt.
4. Reassemble in reverse order.

#### **5.1.15.3 Axis Drive Belts Replacement: Y-Axis DPMRX2, DPMRX3, DPMRX5, & DPMRX7**

1. Remove the electronic handwheel.
2. Remove the belt cover.
3. Loosen motor.
4. Remove and replace belt.
5. Reassemble in reverse order.

#### **5.1.15.4 Axis Drive Belts Replacement: Z-Axis DPMRX2, DPMRX3, DPMRX5, & DPMRX7**

1. Remove the upper motor cover.
2. Loosen motor.
3. Remove and replace belt.
4. Reassemble in reverse order.

#### **5.1.16 Spindle Replacement.**

1. Remove the draw bar and its bushing.
2. Lower the quill about 1 inch and lock.
3. Remove the setscrew from the back of the spindle. Lightly tap at the setscrew location with a soft deadblow hammer to loosen the brass plug.
4. Loosen (unscrew) the large black ring (nosepiece) with a spanner wrench.  
*Note: The nosepiece has a left-hand thread – rotate counterclockwise to loosen.*
5. Using a soft bar about 12 inches long, alternately tap on the top of the spindle and loosen a few threads on the nosepiece until fully unscrewed (the nosepiece will remain attached to the spindle).
6. Continue to tap the spindle out of the quill. The spindle bearings will come out with the spindle.

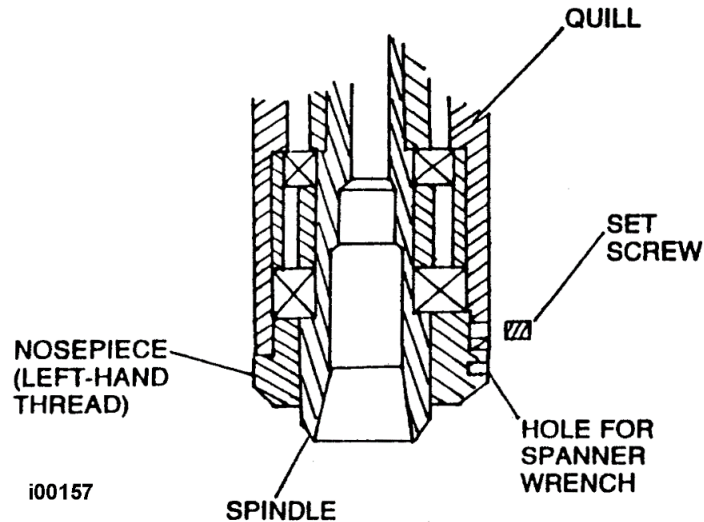

**Figure 61**

## 5.2 Maintenance

### 5.2.1 How to Clean the Touchscreen

When cleaning the touchscreen, make sure to turn off the machine. You can use any window cleaning solution to get any debris off of the screen. It is preferable to use a non-lint cloth when cleaning.

**Note:** *If you clean the screen with the power on, you may get false triggering or no touchscreen detection at all.*

### 5.2.2 Gib Adjustments

The objective of adjusting the gibs is to eliminate as much play in the table, saddle and ram sliding surfaces as possible without having the tightness of the gib interfere with their free movement and cause a decrease in the accuracy and/or performance of the machine due to excessive friction.

#### 5.2.2.1 Table Gib Adjustment: X-Axis DPMRX2, DPMRX3

See Figure 54

1. Clean all chips, dirt and excess oil from the table and saddle.
2. Center the saddle on the bed ways.
3. Move the table fully to the left side of the saddle.

**Note:** *For machines that have excessive wear in the center of the table way, it will be necessary to center the table on the saddle. The resulting adjustment of the gib will be compromised to account for the varying clearance from the center to the ends of the table.*

4. Attach a .0001 dial indicator with a magnetic base to the left front of the saddle. Place the indicator stylus on the front surface of the table as close to the indicator base as possible.

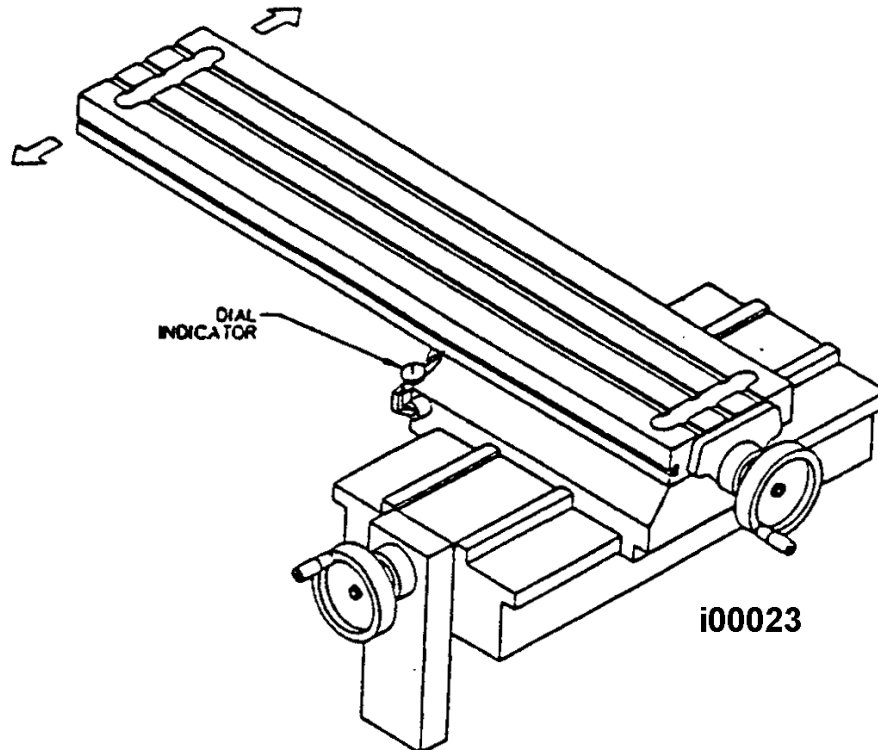

**Figure 62 – DPMRX2 & DPMRX3 Table Gib Adjustment**

5. Move the left end of the table back and forth and note the amount of movement on the dial indicator. Adjust the X-axis gib until the registered movement is 0.0010 - 0.0015.
  - To adjust the gib for excessive clearance: Loosen the gib lock screw on the right end of the saddle. Estimate the amount of gib lock screw adjustment required, and tighten the gib lock screw on the left end of the saddle. Tighten the gib lock screw on the right end of the saddle to lock the give in place, and recheck. Repeat as necessary.
  - To adjust the gib for too small of a clearance: Loosen the gib lock screw on the left end of the saddle. Estimate the amount of gib lock screw adjustment required, and tighten the gib lock screw on the right end of the saddle. Tighten the gib lock screw on the left end of the saddle to lock the gib in place, and recheck. Repeat as necessary.

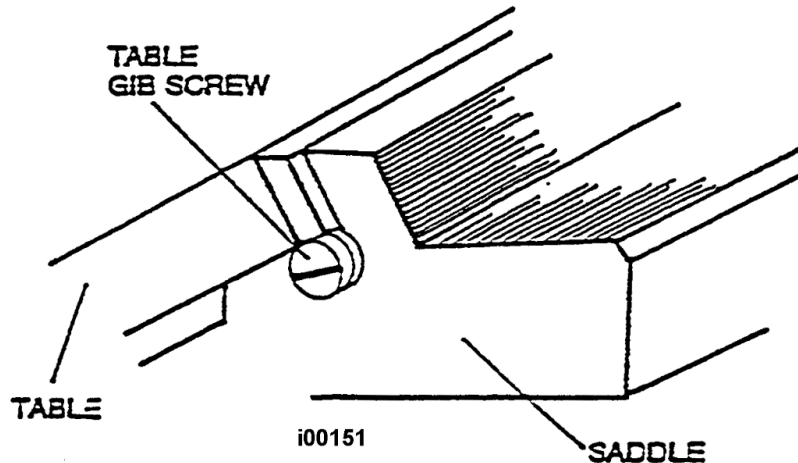

**Figure 63 – Table Gib Screw**

### 5.2.2.2 Gib Adjustment – X-Axis DPMRX5, DPMRX7

The X-axis has 2 gibs for the table because of the length of the saddle. Each gib is adjusted from each end of the table. There are not 2 adjustment screws at either end of the gib like the Y-axis and Z-axis.

**Note:** For the RX7, loosen the two set screws which lock the gib adjustment screw.

1. Clean all chips, dirt and excess oil from the table.
2. Remove the table trays.
3. Move the table to the left and mount the indicator at Point D and move the table back and forth. Note the amount of movement of the dial indicator. Adjust gib until the movement is between 0.0005 - 0.001.
4. Move the table to the right and mount the indicator at Point A and move the table back and forth. Note the amount of movement of the dial indicator. Adjust gib until the movement is between 0.0005 - 0.001.
  - To adjust the gib for excess clearance: Loosen the nut closest to the table and tighten the nut furthest from the table. Once the clearance has been taken up tighten each nut against the gib bracket. Do this for each end of the table.
  - To adjust the gib for too small of a clearance: Loosen the nut furthest from the table and tighten the inside nut up against the bracket to pull the gib away from the machine. Once the clearance has been taken up tighten each nut against the gib bracket. Do this for each end of the table.
5. Replace the table trays.

See figure 64.

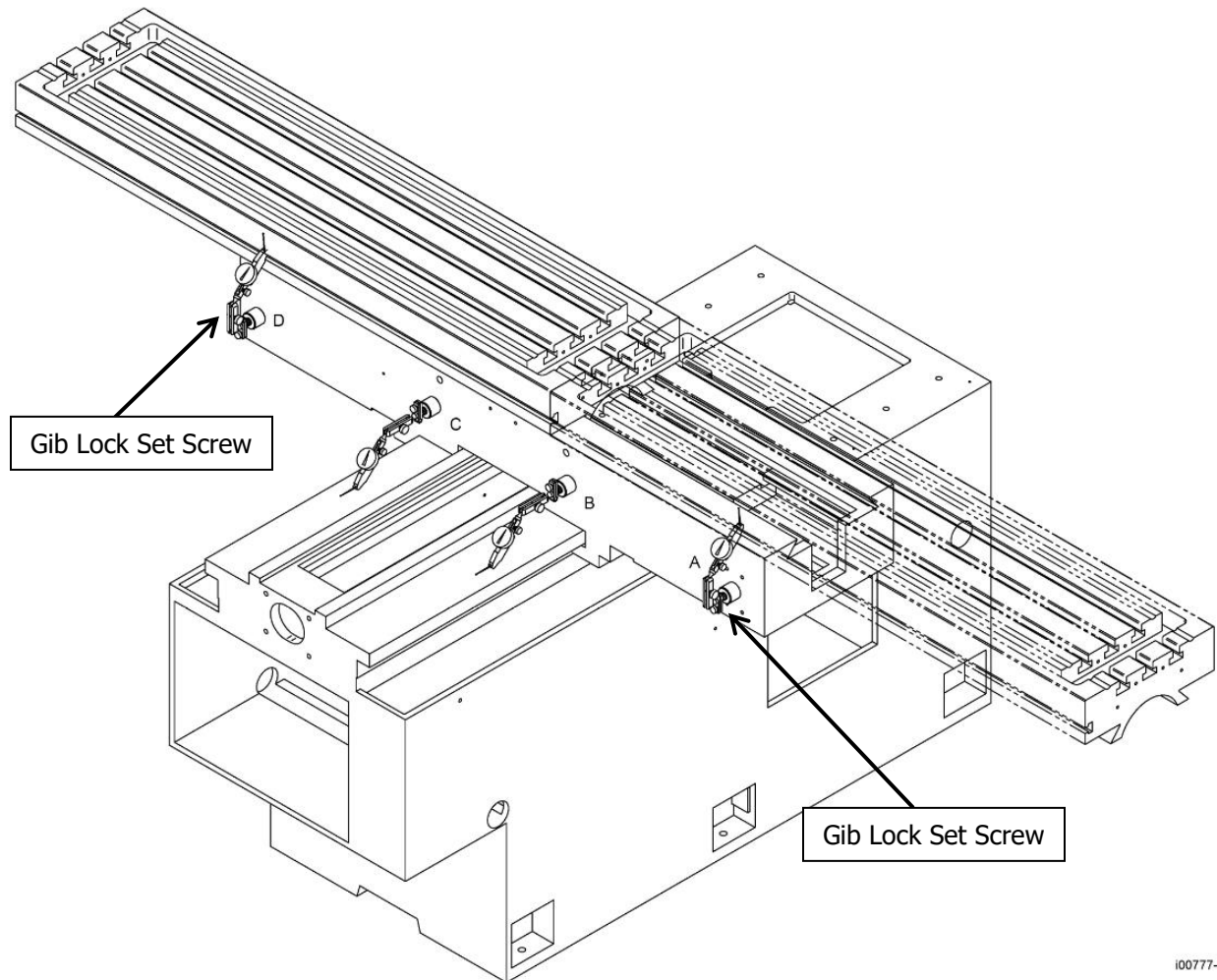

**Figure 64 – DPMRX5 Table Gib & Saddle Bottom Gib Adjustment**

i00777-V5

### 5.2.2.3 Gib Adjustment – X-Axis DPMRX5, DPMRX7

The X-Axis has 2 gibs for the table because of the length of the saddle. Each gib is adjusted from each end of the table. There are not 2 adjustment screws at either end of the gib like the Y-axis and Z-axis.

1. Clean all chips, dirt and excess oil from the table.
2. Remove the table trays.
3. Move the table to the left and mount the indicator at Point D and move the table back and forth. Note the amount of movement of the dial indicator. Adjust gib until the movement is between 0.0005 - 0.001.
4. Move the table to the right and mount the indicator at Point A and move the table back and forth. Note the amount of movement of the dial indicator. Adjust gib until the movement is between 0.0005 - 0.001.

- To adjust the gib for excess clearance: Loosen the nut closest to the table and tighten the nut furthest from the table. Once the clearance has been taken up tighten each nut against the gib bracket. Do this for each end of the table.
  - To adjust the gib for too small of a clearance: Loosen the nut furthest from the table and tighten the inside nut up against the bracket to pull the gib away from the machine. Once the clearance has been taken up tighten each nut against the gib bracket. Do this for each end of the table.
5. Replace the table trays.

#### 5.2.2.4 Saddle Side Gib Adjustment – Y-Axis DPMRX2, DPMRX3, DPMRX5, & DPMRX7

See Figure 66.

1. Clean all chips, dirt and excess oil from the table and saddle.
2. Center the saddle on the bed ways.
3. Move the table fully to the left side of the saddle.
4. Remove the chip wiper guard and chip wiper from the front and rear of the left side box way.

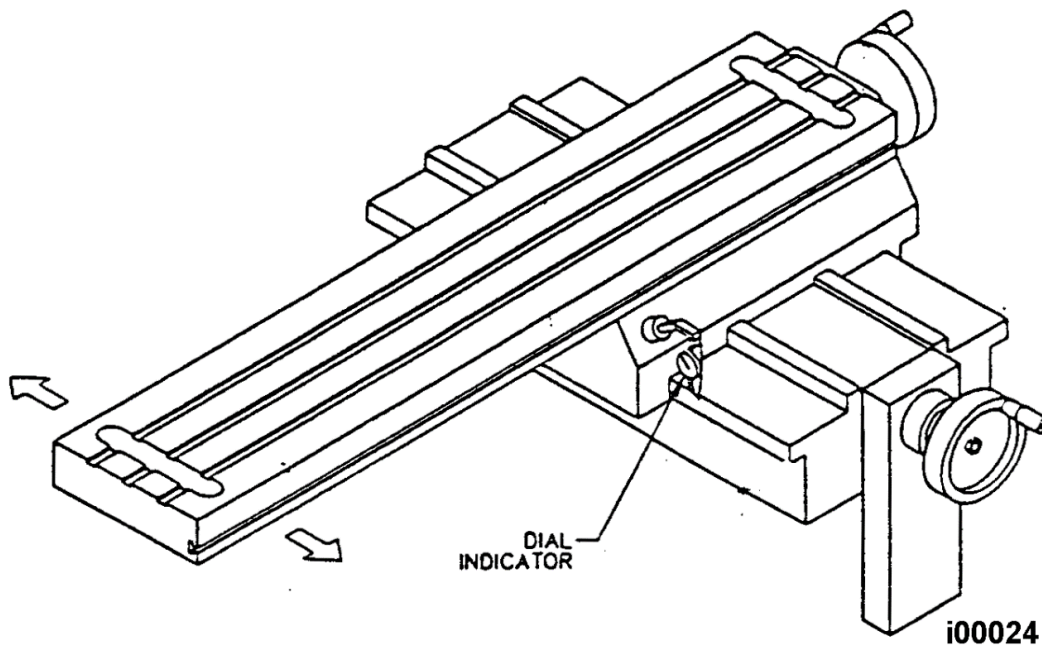

**Figure 66 – DPMRX2, DPMRX3, DPMRX5, & DPMRX7 Saddle Side Gib Adjustment**

5. Attach a .0001 dial indicator with a magnetic base to the left front of the saddle. Place the indicator stylus on the edge of the large box way.
6. Move the left end of the table back and forth and note the amount of movement on the dial indicator. Adjust the Y-axis side gib until the registered movement is .0010-.0015.
  - To adjust the gib for excessive clearance: Loosen the gib lock screw on the back of the saddle. Estimate the amount of gib lock screw adjustment required, and tighten the gib lock screw on the front of the saddle. Tighten the gib lock screw on the back end of the saddle to lock the gib in place, and recheck. Repeat as necessary.



- To adjust the gib for too small of a clearance: Loosen the gib lock screw on the front of the saddle. Estimate the amount of gib lock screw adjustment required, and tighten the gib lock screw on the back of the saddle. Tighten the gib lock screw on the front of the saddle to lock the gib in place, and recheck. Repeat as necessary.
7. Replace the front and rear chip wiper, and chip wiper guard.

#### **5.2.2.5 Saddle Bottom Gib Adjustment – Y-Axis DPMRX2 & DPMRX3 Only**

See Figure 68.

1. Clean all chips, dirt and excess oil from the table and saddle.
2. Center the saddle on the bed ways.
3. Move the table fully to the left side of the saddle.
4. Attach a .0001 dial indicator with a magnetic base to the left front of the saddle. Place the indicator stylus on the top surface of the box way.
5. Lift the end of the table up and note the amount of movement on the dial indicator. Adjust the Y-axis left bottom gib until the registered movement is .0010-.0015.
6. Move the table fully to the right.
7. Reposition the indicator to the right front of the saddle.
8. Lift the right end of the table up and note the amount of movement on the dial indicator. Adjust the Y-axis right bottom gib until the registered movement is .0010-.0015.
  - To adjust the gib for excessive clearance: Loosen the gib lock screw on the back of the saddle. Estimate the amount of gib lock screw adjustment required, and tighten the gib lock screw on the front of the saddle. Tighten the gib lock screw on the back end of the saddle to lock the gib in place, and recheck. Repeat as necessary.
  - To adjust the gib for too small of a clearance: Loosen the gib lock screw on the front of the saddle. Estimate the amount of gib lock screw adjustment required and tighten the gib lock screw on the back of the saddle. Tighten the gib lock screw on the front of the saddle to lock the gib in place, and recheck. Repeat as necessary.

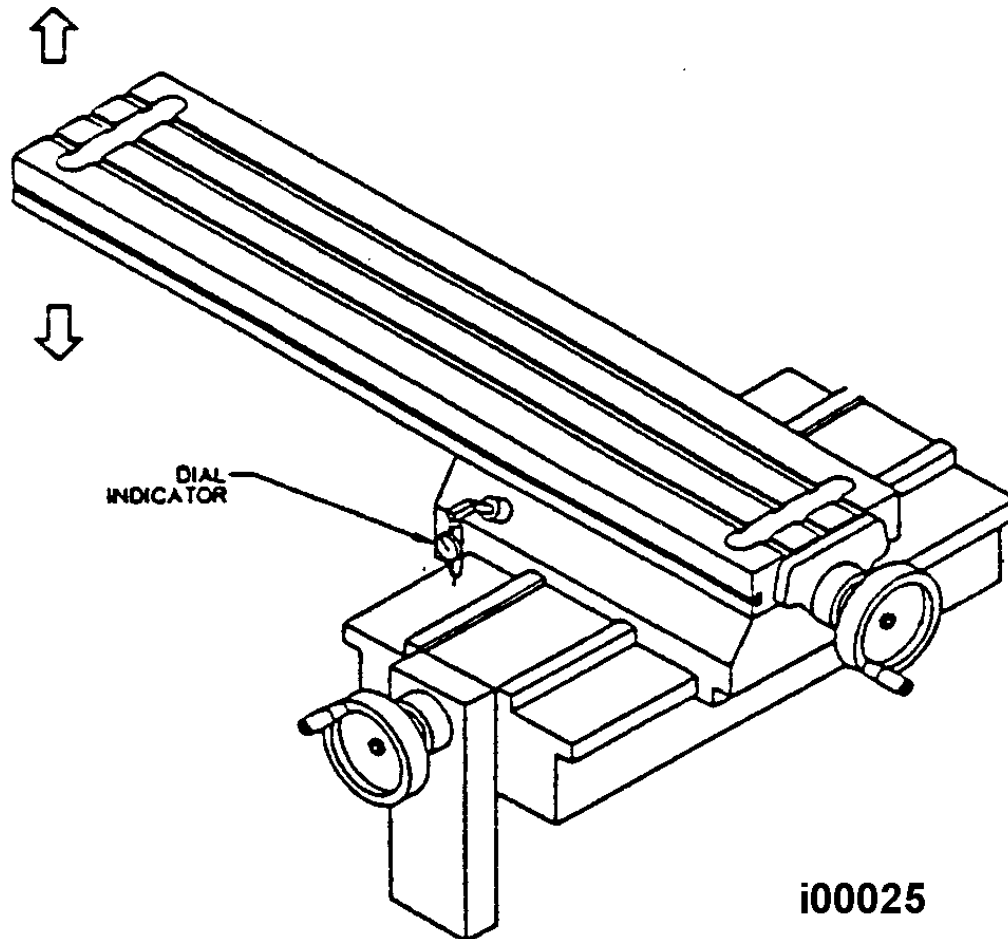

**Figure 68 – DPMRX2 & DPMRX3 Saddle Bottom Gib Adjustment**

#### **5.2.2.6 Saddle Bottom Gib Adjustment – Y-Axis DPMRX5 & DPMRX7 Only**

It is unrealistic to adjust the Y bottom ways the same way as we do on the DPMRX2 & DPMRX3 because of the extra weight of the saddle and table.

1. Clean all chips, dirt and excess oil from the table and saddle.
2. Center the saddle on the bed ways.
3. Mount your indicator on the left side of the saddle with the table in the center of its travel and zero out your indicator.
4. Then move the table all the way to the right side. When the gibs are adjusted properly you should see no more than 0.0003" movement on the indicator.
5. Do the same thing on the right side of the saddle this time moving the table all the way to the left. The reading should be positive on the indicator because the saddle should rise where you are indicating.

**Note:** You can get better readings than 0.0003" but the torque on the Y ball screw may exceed our recommended levels. Remove the ball screw cover and check the torque with an in-lb torque wrench. Normally, the torque should be around 15 in-lbs. Do not exceed 20 in-lbs. Values higher than this may cause circularity problems.

See Figure 56 for an illustration.

- To adjust the gib for excessive clearance: Loosen the gib lock screw on the back of the saddle. Estimate the amount of gib lock screw adjustment required, and tighten the gib lock screw on the front of the saddle. Tighten the gib lock screw on the back end of the saddle to lock the gib in place, and recheck. Repeat as necessary.
- To adjust the gib for too small of a clearance: Loosen the gib lock screw on the front of the saddle. Estimate the amount of gib lock screw adjustment required and tighten the gib lock screw on the back of the saddle. Tighten the gib lock screw on the front of the saddle to lock the gib in place, and recheck. Repeat as necessary.

### 5.2.2.7 Ram Back Gib Adjustment – Z-Axis

1. Clean all chips, dirt and excess oil from the table and saddle.
2. Disconnect one end of the upper and lower way cover where it is attached to the ram.
3. Position the milling head such that the table can be reached by extending the quill approximately 3/4 of its travel.
4. Place a wood block on the table underneath the spindle.
5. Attach a .0001 dial indicator with a magnetic base to the column near the base of the ram on the left side of the machine. Place the indicator stylus on the rear surface of the ram near the bottom.

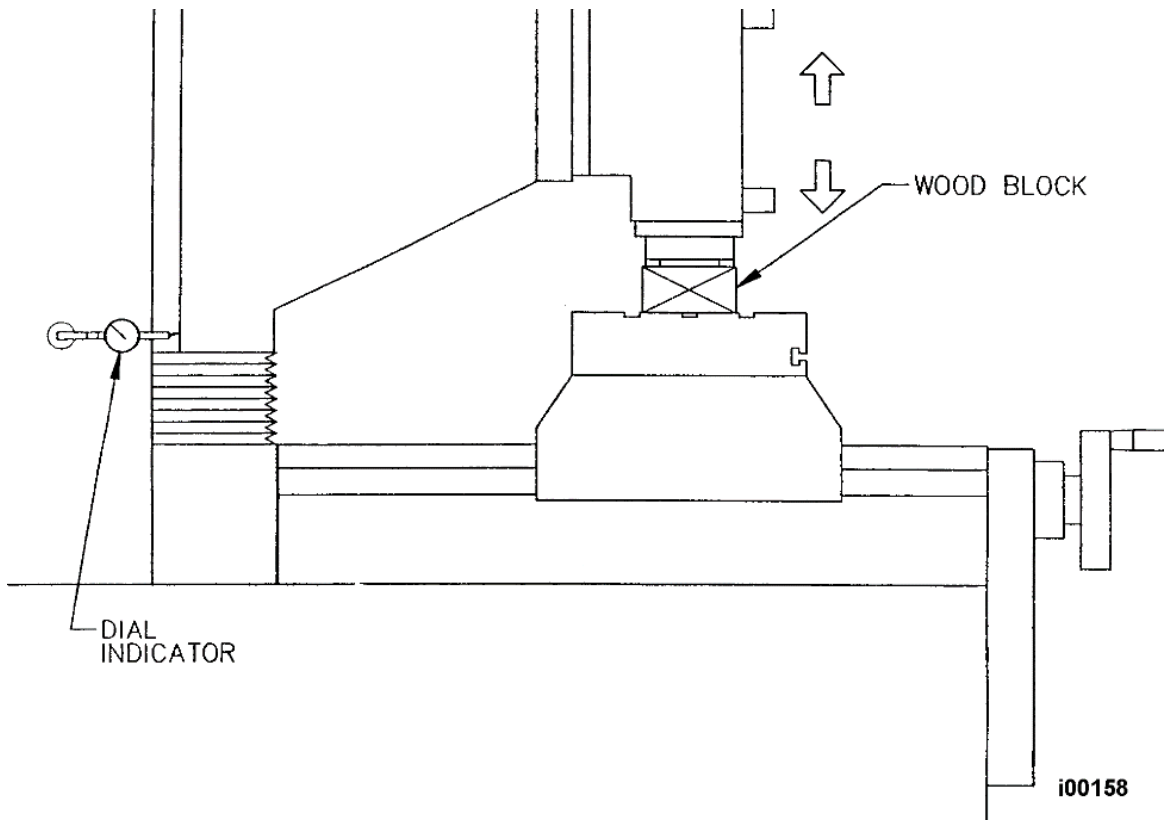

**Figure 69 – Ram Back Gib**

6. Extend the quill until it touches the wood block. Using the quill handle, push the spindle nose against the wood block and note the amount of movement on the dial indicator. For the DPMRX7, use the Z electronic handwheel to move the head down on the wood block. Adjust the left side gib until the registered movement is .001-.0015.
  - To adjust the gib for excessive clearance: Loosen the gib lock screw on the bottom of the ram. Estimate the amount of gib lock screw adjustment required and tighten the gib lock screw on the top of the ram. Tighten the gib lock screw on the bottom of the ram to lock the gib in place, and recheck. Repeat as necessary.
  - To adjust the gib for too small of a clearance: Loosen the gib lock screw on the top of the ram. Estimate the amount of gib lock screw adjustment required and tighten the gib lock screw on the bottom of the ram. Tighten the gib lock screw on the bottom of the ram. Tighten the gib lock screw on the top of the ram to lock the gib in place, and recheck. Repeat as necessary.
7. Run Service Code 12 to see the feed forward constant.
8. Repeat the procedure for the back gib on the right side of the machine.

**CAUTION!**

Be careful not to over tighten the ram gibs. Over tightening may lead to faulting and repeatability problems. Double-check the gib adjustment by checking the torque on the Z-axis. Use an in-lb torque wrench on top of the ball screw and typical readings should be from 12-17 in-lbs and consistent across the Z travel.

#### **5.2.2.8 Ram Side Gib Adjustment – Z-Axis**

1. Clean all chips, dirt and excess oil from the column ways.
2. Attach a .0001 dial indicator with a magnetic base towards the rear of the table on the right side of the ram. Place the indicator stylus on the ram in line and below the lower mounting bolt for the coolant hose connector block. (See Figure 55)
3. Lock and unlock the lower ram side gib lock and note the amount of movement on the dial indicator. Adjust the ram side gib until the registered movement is 0.0005 - 0.0010.
  - To adjust the gib for excessive clearance: Loosen the gib lock screw on the bottom of the ram. Estimate the amount of gib lock screw adjustment required, and tighten the gib lock screw on the top of the ram. Tighten the gib lock screw on the bottom of the ram to lock the gib in place, and recheck. Repeat as necessary.
  - To adjust the gib for too small of a clearance: Loosen the gib lock screw on the top of the ram. Estimate the amount of gib lock screw adjustment required and tighten the gib lock screw on the bottom of the ram. Tighten the gib lock screw on the top of the ram to lock the gib in place, and recheck. Repeat as necessary.
4. Run Service Code 12 to set the feed forward constant.
5. Reattach the upper and lower way cover to the ram.

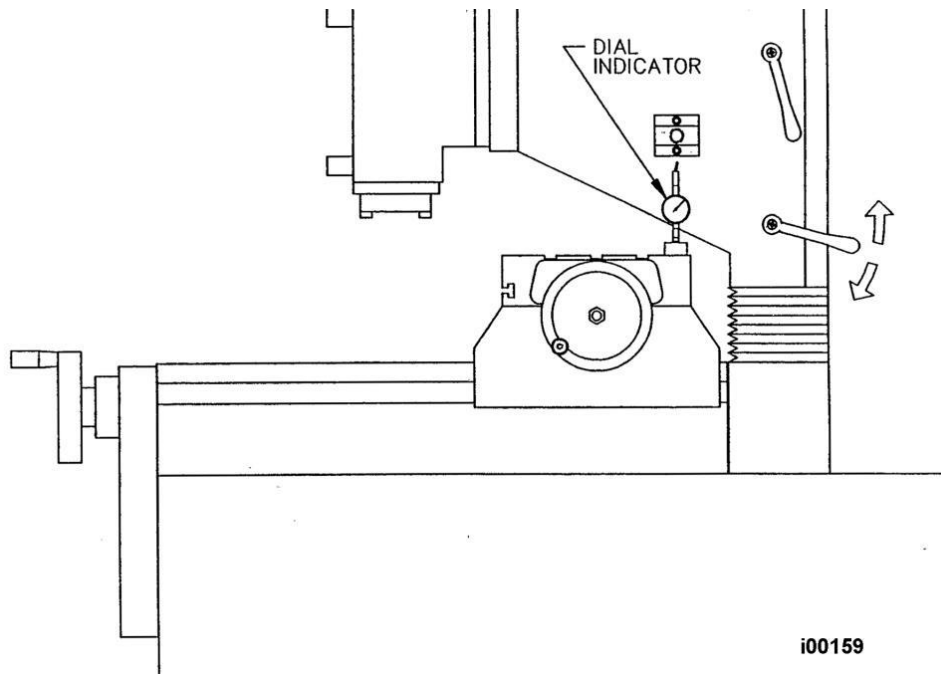

**Figure 70 – Ram Side Gib Adjustment**

### 5.2.3 Calibration & Backlash Constants

Calibration and backlash constants were set as part of the installation and set-up of your system. They should be re-set when indicated in the Troubleshooting section or after the replacement of the Computer module, or any parts of the drive train.

#### 5.2.3.1 X, Y, Z Ram & Quill Calibration

Calibration is used to teach the machine a known distance. We typically calibrate our machines over a 150 mm distance. There is no limit to how far you can calibrate the machine.

1. Set-up a gauge block or standard and indicate it parallel to the axis you are calibrating.

**Note:** Put the display in Inch or mm to match your gage block. Recommended gage blocks are:

- X and Y -- 150mm or 6"
  - Z -- 75 mm or 3"
2. Set a 0.0001" indicator in the spindle and move it up to one side of the gage block or standard.
  3. Go to setup mode, go to section "B" and press CODE 123.
  4. Select the axis you want to calibrate X, Y or Z. For the quill press the F1 key labeled QUILL.
  5. Follow the instructions on the screen to complete calibration.

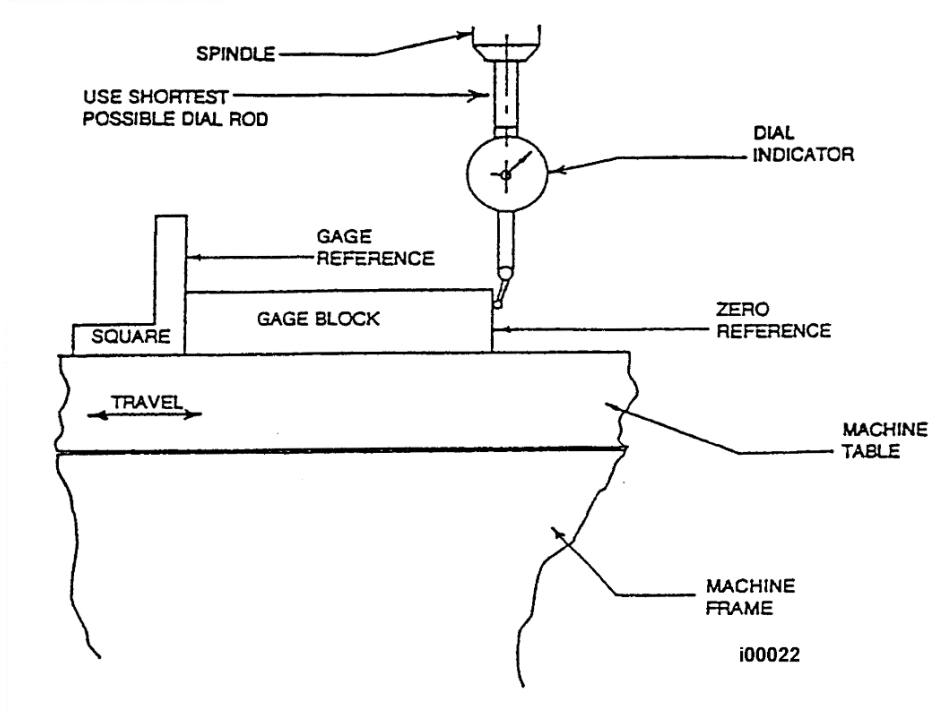

**Figure 71 – Calibration Set-Up**

### 5.2.3.2 Backlash Compensation

#### Code 11: Set X or Y backlash constant

Note: This procedure is on systems with Glass Scales only.

Go to Setup Mode, go to section "B" and press CODE 11. Refer to service code section for further explanation.

***The backlash can also be found manually with a 0.0001" indicator with the following method:***

1. Load the indicator to zero from one direction and zero out the DRO.
2. Move the indicator to 0.002" and then back to zero. Do not over shoot 0, otherwise start over.
3. Whatever number appears on the screen is the backlash value.
4. Enter this value into service code 128.
5. After entering this number redo the process. The DRO and indicator should now both read 0.

#### Code 128: Input Backlash Constant

Code 128 allows you to enter the backlash values for each axis. It displays the value after it enters. This code is only used on machines with motor encoders only.

## 5.2.4 Head Rotation & Tramming

The TRAK Bed Mills DPMRX 2, DPMRX3 and DPMRX5 heads are free to rotate up to 90 degrees to the right or left (when facing the machine).

### **CAUTION!**

The head must be supported while rotating to prevent stripping the worm gear.

### **CAUTION!**

The DPMRX7 heads will rotate to a maximum angle of 30 degrees to the right and 90 to the left (when facing the machine).

### 5.2.4.1 To Rotate the Head

1. Loosen the four locknuts.
2. Rotate the head with the adjusting worm shaft.
3. Tighten the locknuts. Snug each locknut, then lightly tighten each locknut, then fully tighten each locknut in a crisscross pattern to 50 ft-lbs.
4. Use the method shown in the figure below and a parallel bar to square the head to the table.

### 5.2.4.2 Tramming the Head

The purpose of tramming the head is make sure the head is perpendicular to the top of the table from both side to side and back to front.

Side to side tolerance – 0.001"

#### ***Side-to-Side Alignment***

1. Make sure the machine is leveled.
2. Make sure the table has been clean and the Z gibs are adjusted properly. Mount a dial indicator in a tool holder and mount in the quill.
3. Adjust the Y-axis so that the spindle is in the center of the table.
4. Adjust the Z ram so that the dial indicator will reach the table.
5. Move the dial indicator to 6 o'clock position and adjust the face so the needle is zero.
6. Do a series of sweeps from 3 o'clock to 9 o'clock and check for the repeatability of the setup. The head should be trammed with a 0.001"
7. If the head is out of tram from side to side then loosen the 4 head bolts and rotate the head with the worm shaft.
8. Once the head has been trammed tighten the 4 heads bolts. Be careful not to move the head while tightening. Tighten the bolts in a criss-cross pattern.

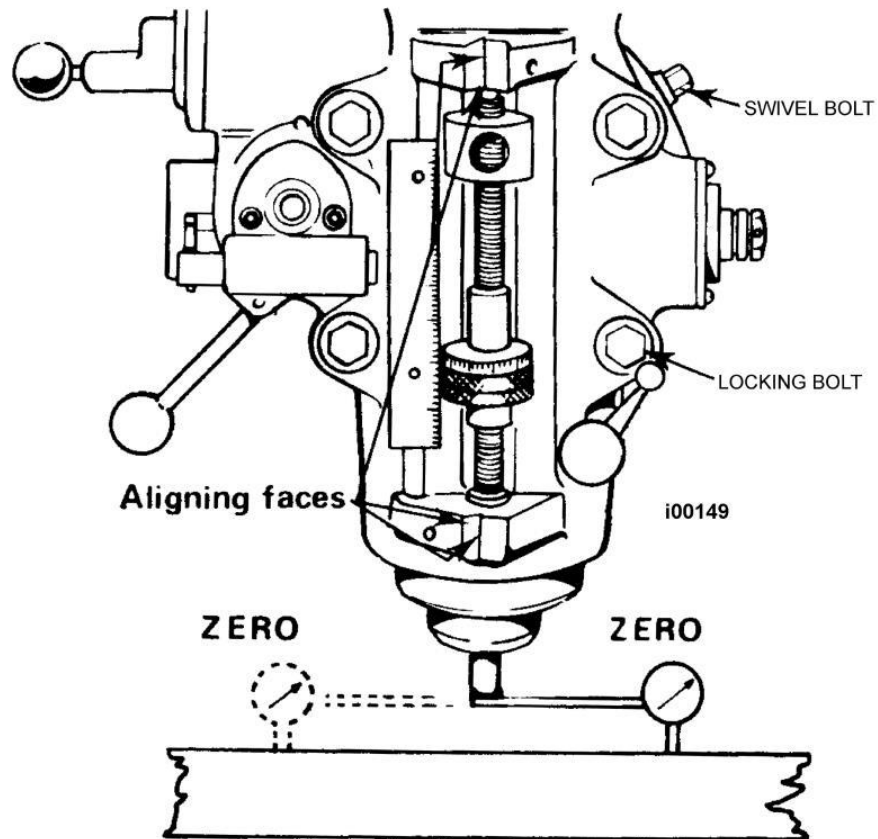

**Figure 72 – Tramping of the Head**

### ***Back-to-Front Adjustment***

**Note:** The head of the DPM bed mills machine is adjusted at the factory. This procedure should only be needed for a head replacement. It is placed in this section for continuity with the tramping discussion.

With the dial indicator sweep the table from 6 o'clock to 12 o'clock. The head should be tramped within 0.0000 to 0.0005" from front to back. (**Note:** the head must droop down rather than up because tool pressure will take care of the extra 0.0005".)

**Note:** Minor adjustments can be made with the back ram gibs. Tightening the gibs will tend to tilt the head up from the table. Loosening the gibs tends to allow the head to droop down toward the table. Over tightening or loosening can lead to other problems with the machine. Typical adjustments with the gibs is 0.0005" or less.

### **5.2.4.3 Y & Z-Axis Limit Switch Stops**

The limit switch-stops for the Y-axis are mounted on the side of the bed. The limit switch is triggered by hitting the cam stop on the saddle. The cam is placed to ensure maximum travel.

See Section 7.0 figures and parts lists for the diagrams and parts lists of the different DPMRX bed mills and the limit switch part numbers.



## 6.0 Introduction to Self-Service

The objective of this section of the manual is to allow the user of the ProtoTRAK Control to resolve the majority of potential service problems.

This manual assumes that the user is not experienced with CNC troubleshooting and repairs. Special tools are not required for the procedures described in the manual.

Please see Sections 3 for basic troubleshooting sections of the manual.

### 6.1 When You Have a Service Problem

TMT/SWI recommends that you consult this manual or our web site first. We also have a Dozuki site with detailed troubleshooting procedures <https://trakmtsupport.dozuki.com/>. Often it will be possible for you to resolve the problem yourself or isolate the problem to a particular cause.

Your next step is to contact the TMT/SWI Customer Service Group for assistance.

#### 6.1.1 Communication with the Customer Service Group

TMT/SWI Service Department Direct Line: (800) 367-3165

Web Address: [www.trakmt.com](http://www.trakmt.com)

This phone line rings directly into the TMT/SWI Customer Service Group. If a Customer Service Representative (CSR) is not available within the first few of minutes, your call is transferred into our voice mail system.

Our voice mail is continuously monitored. If you have an emergency, indicate this in your message. Our Service Voice Mail box number is 555.

TMT/SWI Service Department Direct Fax Number: (310) 886-8029  
Customer Service Group hours: Monday - Friday 7:00 AM to 4:30 PM PT  
(TMT/SWI observes a normal holiday schedule)

## 6.2 Replacements

### 6.2.1 Exchange Program

TMT/SWI keeps in stock the major subassemblies required to resolve service problems. With very few exceptions, the part needed to resolve any given service problem is on the shelf and ready to ship.

A little bit of troubleshooting on your part means that we can get the right part to you fast.

After replacing the failed unit with the replacement unit, simply put the failed unit in the same box that the replacement part came in and ship it back to us via UPS ground service.

This unique Exchange program gives our customers access to refurbished "like-new" subassemblies that have been brought up to current design revisions and go through the same QC procedures as our new products. These high-quality replacement units are available at a fraction of the price of a new subassembly.

### **6.2.2 Return Material Authorization (RMA) Number**

All shipments of replacement parts are accomplished through our Return Material Authorization (RMA) system. At the same time the CSR is diagnosing the problem and ordering the part, they will issue an RMA number that will allow us to efficiently process the return part.

# TRAK Warranty Policy

## Warranty

TRAK products are warranted to the original purchaser to be free from defects in workmanship and materials for the following periods:

Product	Warranty Period	
	Materials	Factory Labor
New TRAK/ProtoTRAK	1 Year	1 Year
Any EXCHANGE Unit	90 Days	90 Days

The warranty period starts on the date of the invoice to the original purchaser from Southwestern Industries, Inc. (SWI) or their authorized distributor.

If a product, subsystem or component proves to be defective in workmanship and fails within the warranty period, it will be repaired or exchanged at our option for a properly functioning unit in similar or better condition. Such repairs or exchanges will be made FOB Factory/Los Angeles or the location of our nearest factory representative or authorized distributor.

## Warranty Disclaimers

- This warranty is expressly in lieu of any other warranties, express or implied, including any implied warranty of merchantability or fitness for a particular purpose, and of any other obligations or liability on the part of SWI (or any producing entity, if different).
- Warranty repairs/exchanges do not cover incidental costs such as installation, labor, freight, etc.
- SWI is not responsible for consequential damages from use or misuse of any of its products.
- TRAK products are precision mechanical/electromechanical/electronic systems and must be given the reasonable care that these types of products require. Evidence that the product does not receive adequate Preventative Maintenance may invalidate the warranty. Excessive chips built up around ballscrews and way surfaces is an example of this evidence.
- Accidental damage, beyond the control of SWI, is not covered by the warranty. Thus, the warranty does not apply if a product has been abused, dropped, hit or disassembled.
- Improper installation by or at the direction of the customer in such a way that the product consequently fails, is considered to be beyond the control of the manufacturer and outside the scope of the warranty.
- Warranty does not cover wear items that are consumed under normal use of the product. These items include, but are not limited to: windows, bellows, wipers, filters, drawbars and belts.

## Extended Warranty

If an extended warranty has been purchased, the terms and conditions listed above shall apply for the extended warranty period.

## **7.0 Figures & Parts List**

<b>29106</b>	<b>System Diagram – DPMRX Bed Mills</b>
<b>29400</b>	<b>X Axis Drive Assy, DPMRX2</b>
<b>29401</b>	<b>Y axis Drive Assy, DPMRX2/3</b>
<b>29402</b>	<b>Drive Assy – Z Axis DPMRX3/5</b>
<b>29403</b>	<b>Drive Assy – Drive Assy – X Axis – DPMRX3</b>
<b>29406</b>	<b>Drive Assy – X Axis, DPMRX5</b>
<b>29407</b>	<b>Drive Assy – Y Axis, DPMRX5</b>
<b>29464</b>	<b>Drive Assy-X Axis-DPMRX7</b>
<b>29465</b>	<b>Drive Assy – Y Axis DPMRX7</b>
<b>29466</b>	<b>Drive Assy – Z Axis DPMRX7</b>
<b>29063-2</b>	<b>Coolant Pump Mounting – DPMRX2, DPMRX3, DPMRX5</b>
<b>24581-2</b>	<b>Complete Head Assy – DPMRX2</b>
<b>23964-XX</b>	<b>Complete Head Assy DPMRX3, DPMRX5</b>
<b>Figure 60</b>	<b>Complete Head Assy – DPMRX7</b>
<b>Figure 61</b>	<b>Upper Head – DPMRX7</b>
<b>Figure 61b</b>	<b>Lower Head Assembly</b>
<b>Figure 62</b>	<b>Lower Head Assy – DPMRX7</b>
<b>Figure 63</b>	<b>DPMRX7 Power Module</b>
<b>24406</b>	<b>Lower Head Housing Assy, DPMRX2</b>
<b>24411</b>	<b>Lower Head Housing Assy-White-40 T</b>
<b>29510</b>	<b>Limit Switch Kit – DPMRX2</b>
<b>29510-1</b>	<b>Limit Switch Kit – DPMRX3</b>
<b>29510-2</b>	<b>Limit Switch Kit – DPMRX5</b>
<b>29510-3</b>	<b>Limit Switch Kit – DPMRX7</b>

NOTICE: THIS DESIGN WAS ORIGINATED BY AND EMBODIES A CONFIDENTIAL PROPRIETARY DESIGN OWNED BY SOUTHWESTERN INDUSTRIES. IT IS DISCLOSED IN CONFIDENCE FOR A SPECIFIC PURPOSE AND THE RECIPIENT HEREOF AGREES NOT TO MAKE ANY REPRODUCTION, DISCLOSURE OR OTHER USE OF THIS INFORMATION WITHOUT THE WRITTEN CONSENT OF SOUTHWESTERN INDUSTRIES.  
 © SOUTHWESTERN INDUSTRIES, INC. 2018 ALL RIGHT RESERVED

REVISIONS		ECN	DATE	DFT	ENG
REV	DESCRIPTION				
A	PRODUCTION RELEASE.	14905	08/10/18	AC	AW
B	(2C7) CABLE ASSY 23490-5 WAS: 24619-7. ADDED PART NUMBERS FOR OPTIONS	15011	03/14/19	AC	AW

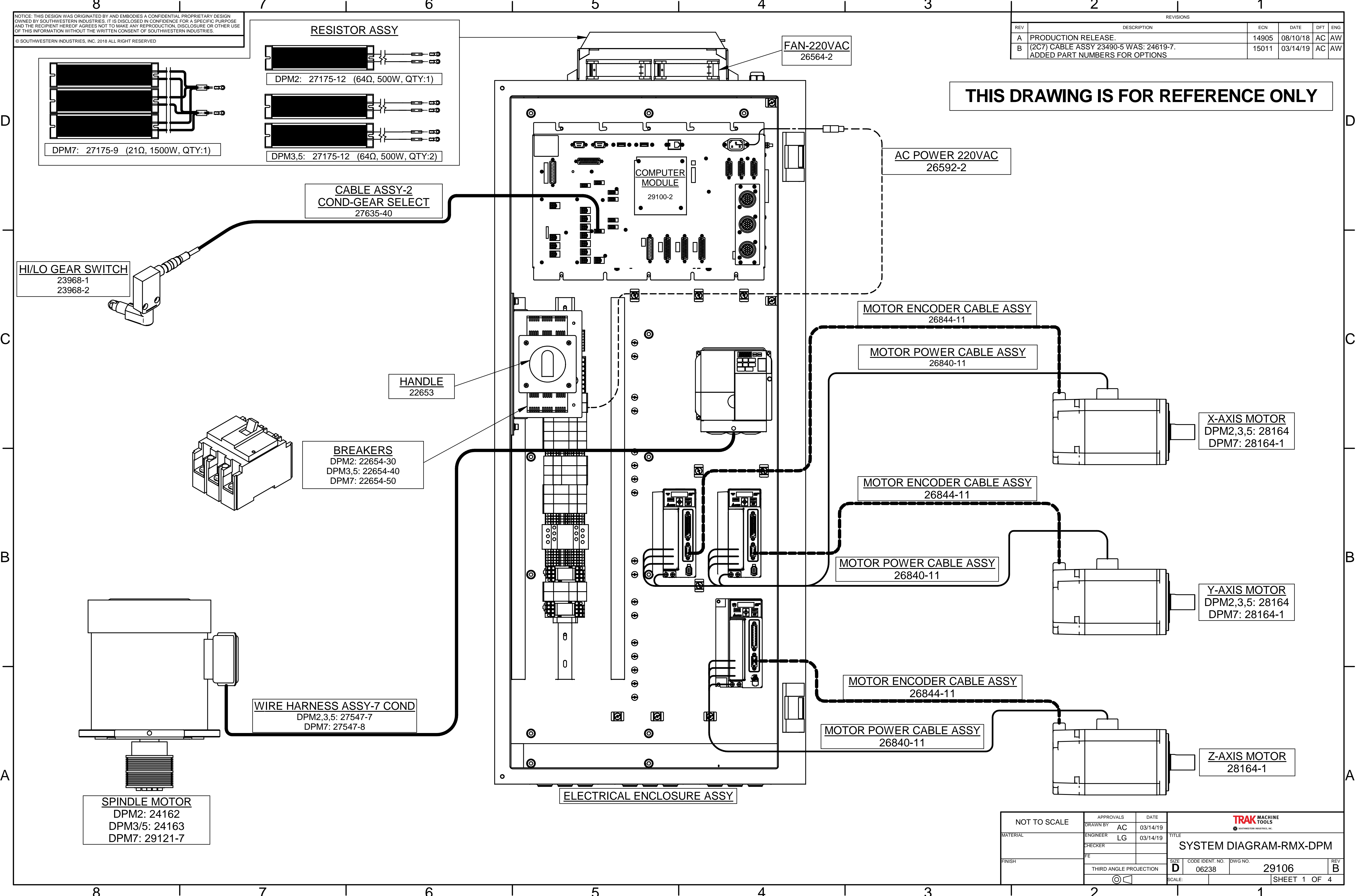

**THIS DRAWING IS FOR REFERENCE ONLY**

NOT TO SCALE		APPROVALS	DATE		
MATERIAL	ENGINEER	AC	03/14/19	TITLE	
	CHECKER	LG	03/14/19	SYSTEM DIAGRAM-RMX-DPM	
FINISH	FE			SIZE	CODE IDENT. NO.
				D	06238
				DWG NO.	29106
				REV	B
				SCALE:	SHEET 1 OF 4

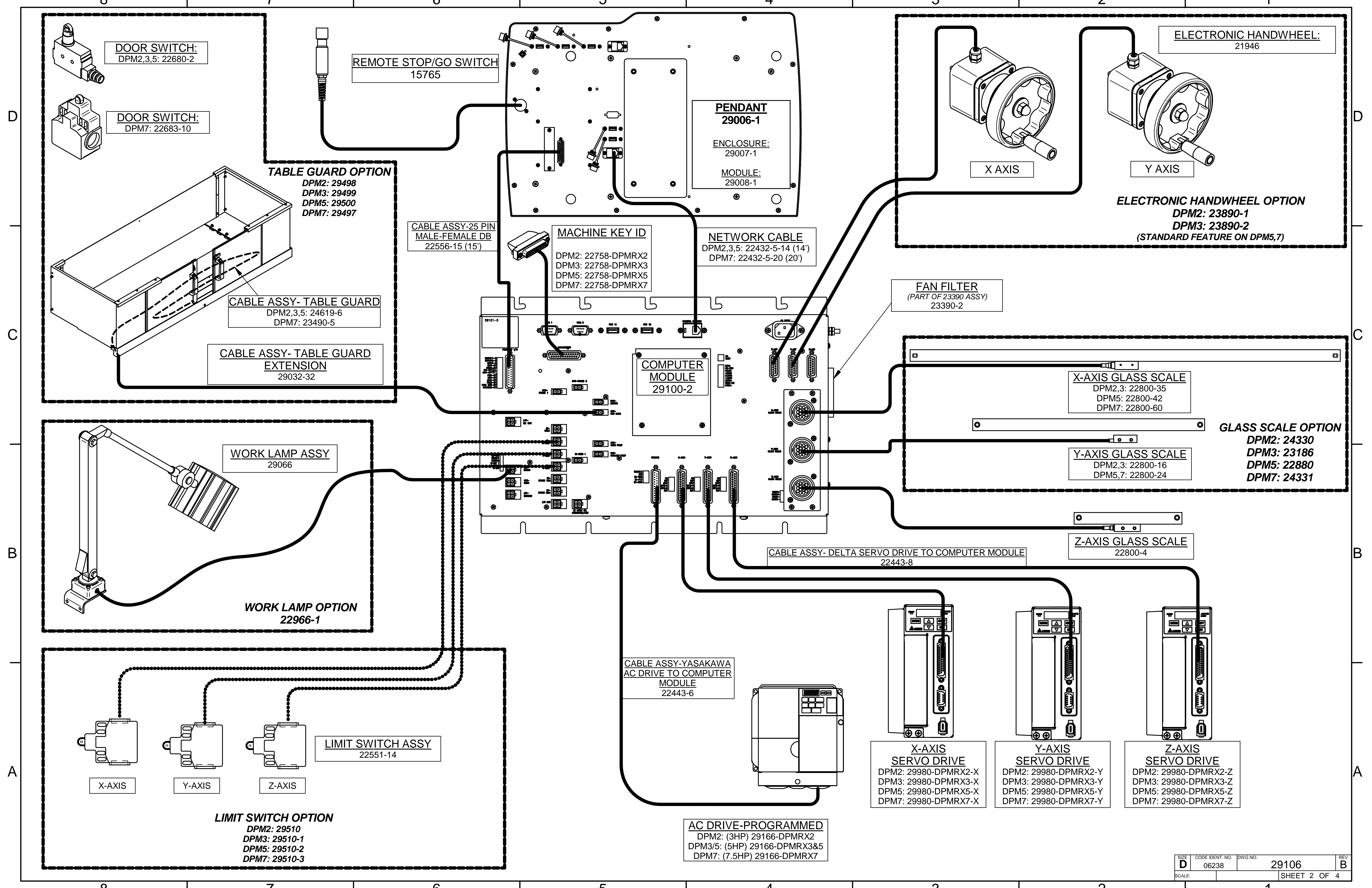



CABLE CHART

CABLE ASSY/LABEL	WIRE FROM	WIRE LABEL	WIRE GAGE	COLOR	WIRE TO
AUX-I/O	TB50-1	I24DC	22 AWG	RED	COMPUTER MODULE I/O AUX
	TB51-1	IN	22 AWG	GREEN	
	TB52-1	NO-1	22 AWG	WHITE	
	TB53-1	NO-2	22 AWG	BLACK	
AUX-POWER OUT	TB54-1	24DC	22 AWG	RED	COMPUTER MODULE OUT-24DC
	TB55-1	0DC	22 AWG	BLACK	
	TB55-2	0DC	22 AWG	GREEN	
	TB56-1	E24DC	22 AWG	WHITE	

**AUXILIARY FUNCTION OPTION  
29600**

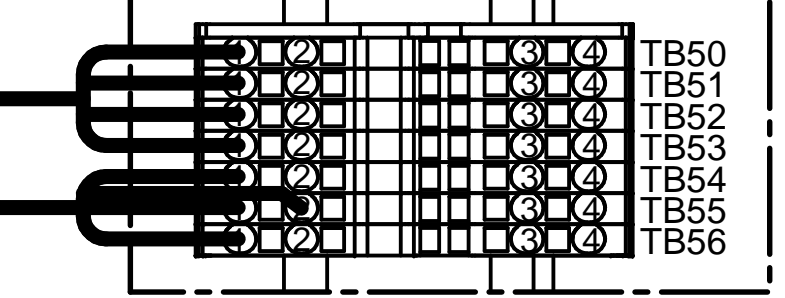

**DETAIL A**

CABLE ASSY-AUX-POWER-OUT  
29032-31

CABLE ASSY-AUX I/O  
29032-30

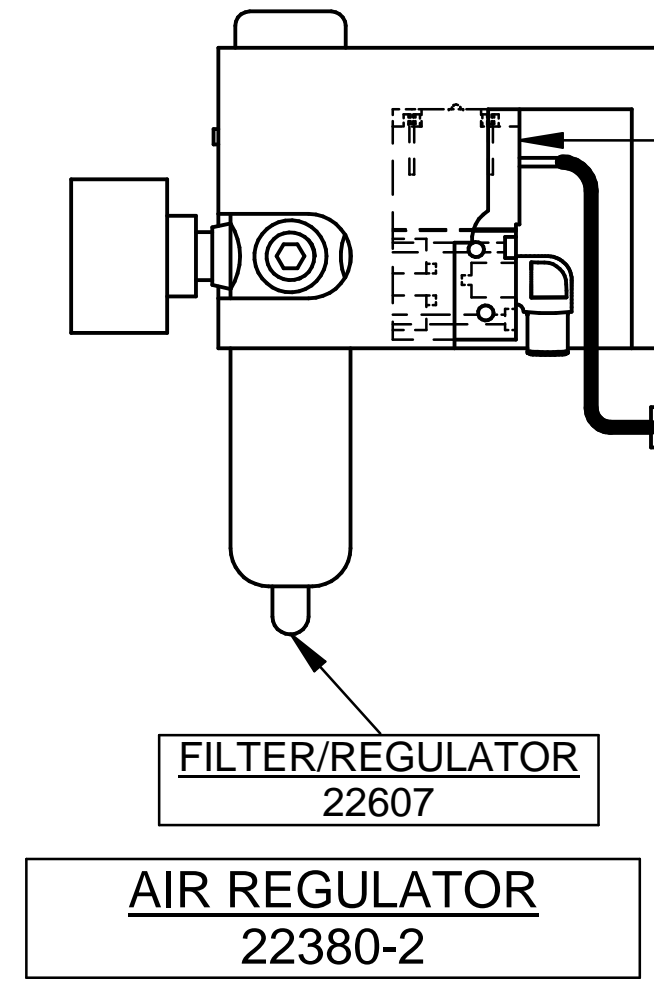

SOLENOID ASSY  
22772-1

CABLE ASSY-MISTER  
22609-1

FILTER/REGULATOR  
22607

AIR REGULATOR  
22380-2

**COOLANT PUMP OPTION  
DPM2,3,5: 29091  
DPM7: 29091-1**

WIRE CHART

WIRE FROM	TYPE OF TERMINAL FROM	WIRE LABEL	WIRE GAGE (awg)	WIRE LENGTH (in)	COLOR	WIRE TO	TYPE OF TERMINAL TO
TB3-3	FERRULE	L1-3	14	28	BLACK	F18-1	FERRULE
TB6-3	FERRULE	L2-3	14	28	BLACK	F19-1	FERRULE
F18-2	FERRULE	L1-10	14	10	BLACK	K5-12	FORK
F19-2	FERRULE	L2-10	14	10	BLACK	K5-9	FORK

F18, F19 FUSES ARE  
2 AMP RATED, TIME DELAY  
23152-2

CABLE CHART

CABLE ASSY/LABEL	WIRE FROM	WIRE LABEL	WIRE GAGE	COLOR	WIRE TO
COOLANT PUMP POWER	K5-8	L1-11	16AWG	WHITE	COOLANT PUMP
	K5-5	L2-11	16AWG	BLACK	
	GS28	GND	16AWG	GREEN	
COOLANT RELAY COMP TO K5	K5-14	E24DC-PS0	22AWG	RED	COMPUTER MODULE OUT-COOLANT PUMP
	K5-13	0DC	22AWG	BLACK	

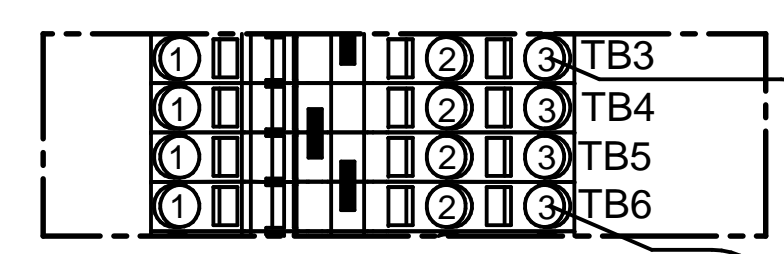

**DETAIL B**

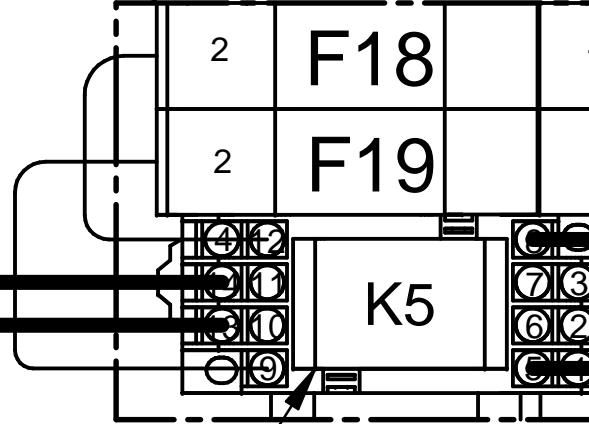

**DETAIL C**

RELAY-24DC  
COIL-4PDT  
26567-1

CABLE ASSY-  
COOLANT PUMP POWER  
27176-9

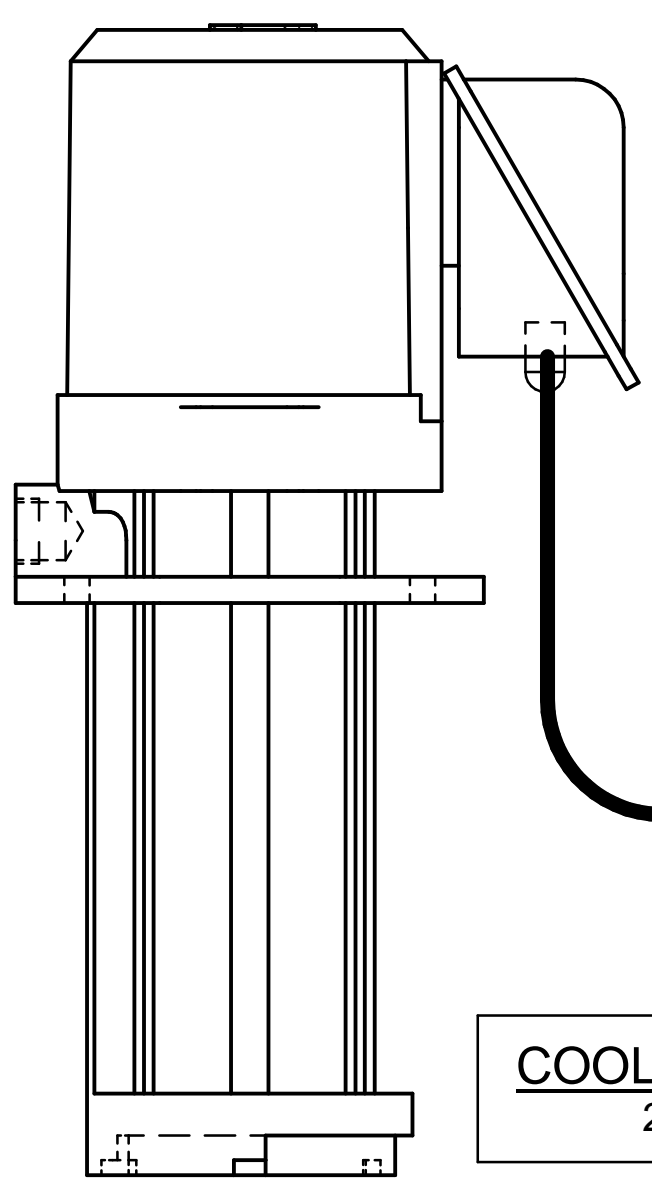

COOLANT PUMP  
29063-2

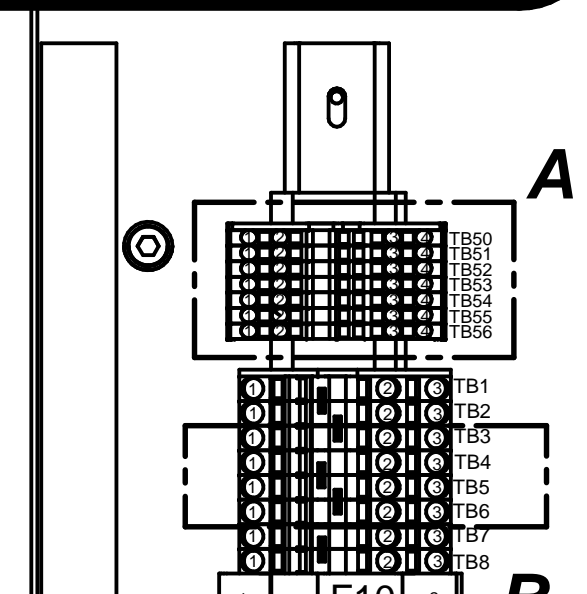
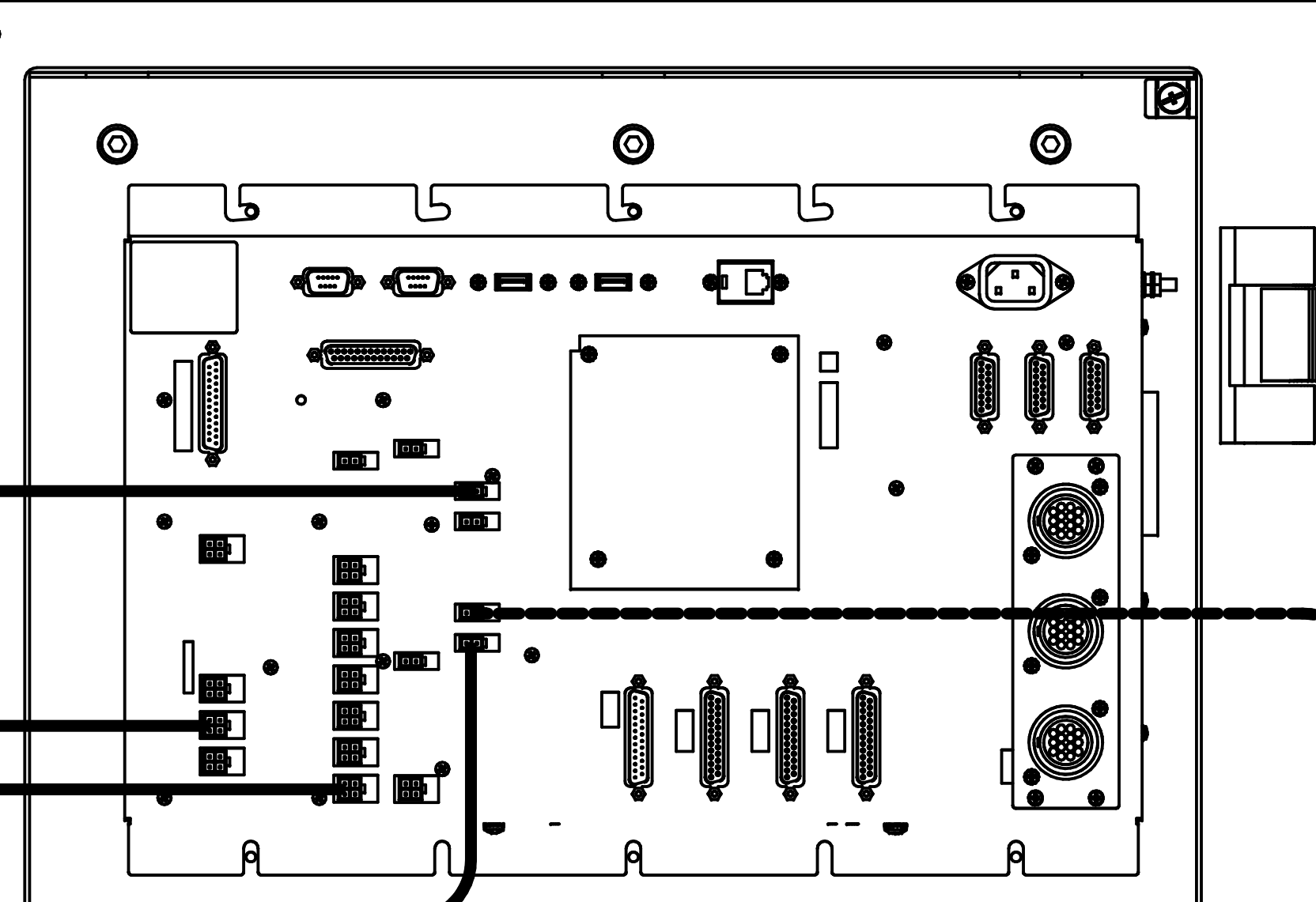

CABLE ASSY-2  
COND-LUBE  
PUMP-COMP TO K4  
27635-30

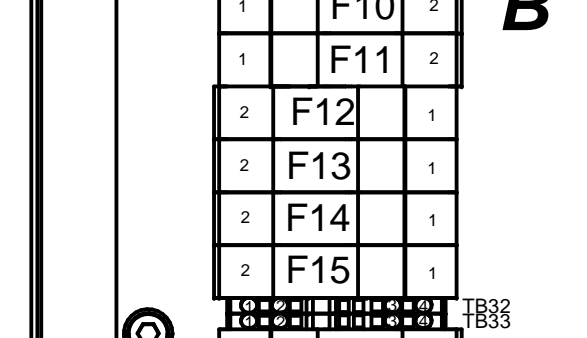

CABLE ASSY-3  
COND-LUBE PUMP  
(PART OF 29065-1)  
27176-8

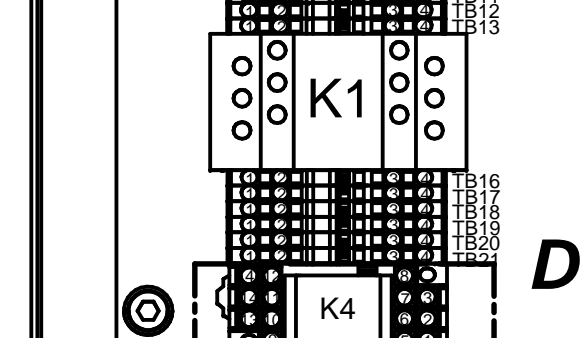
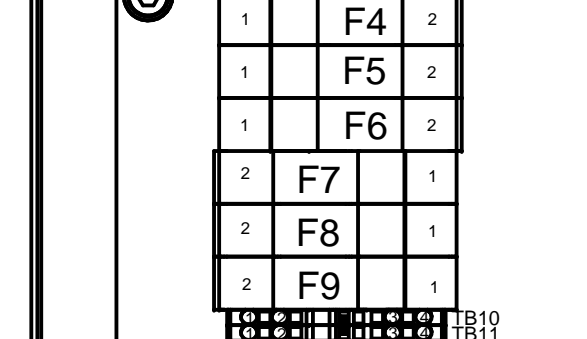

LUBE PUMP  
29065-1

# DPMRX TERMINAL BLOCKS:

## DPMRX2:

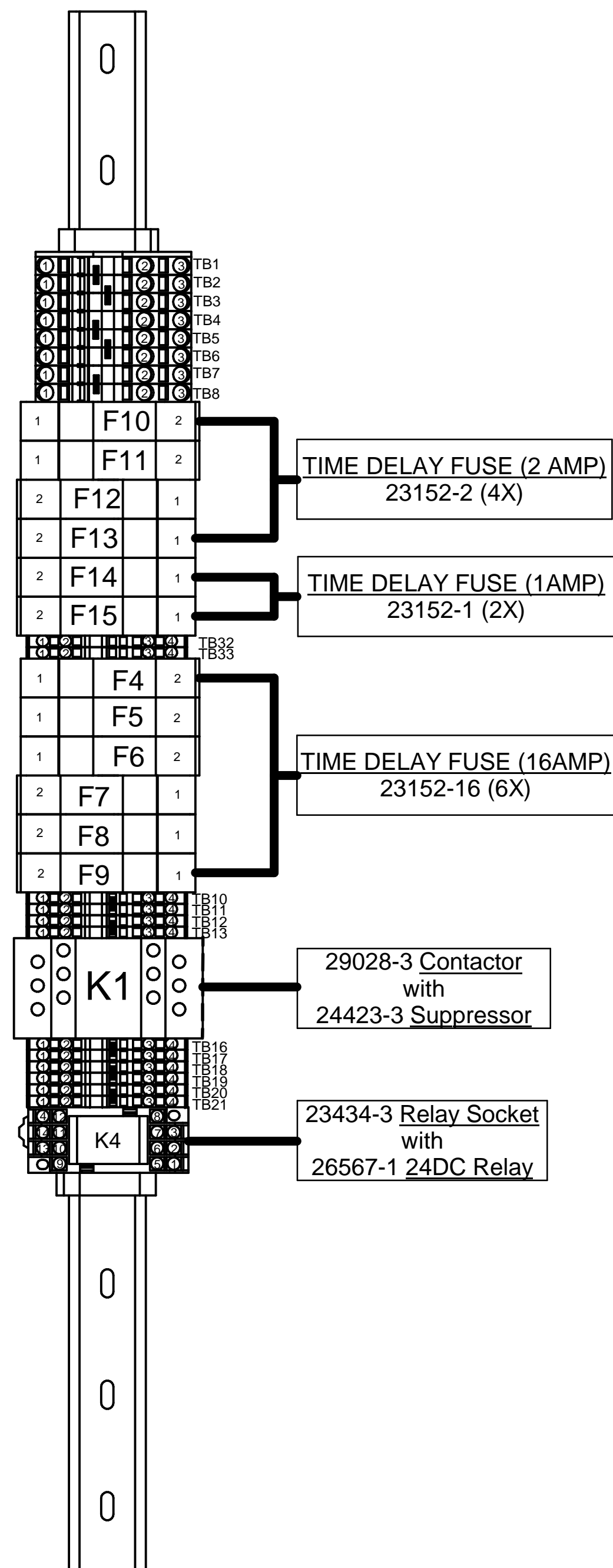

## DPMRX3&5:

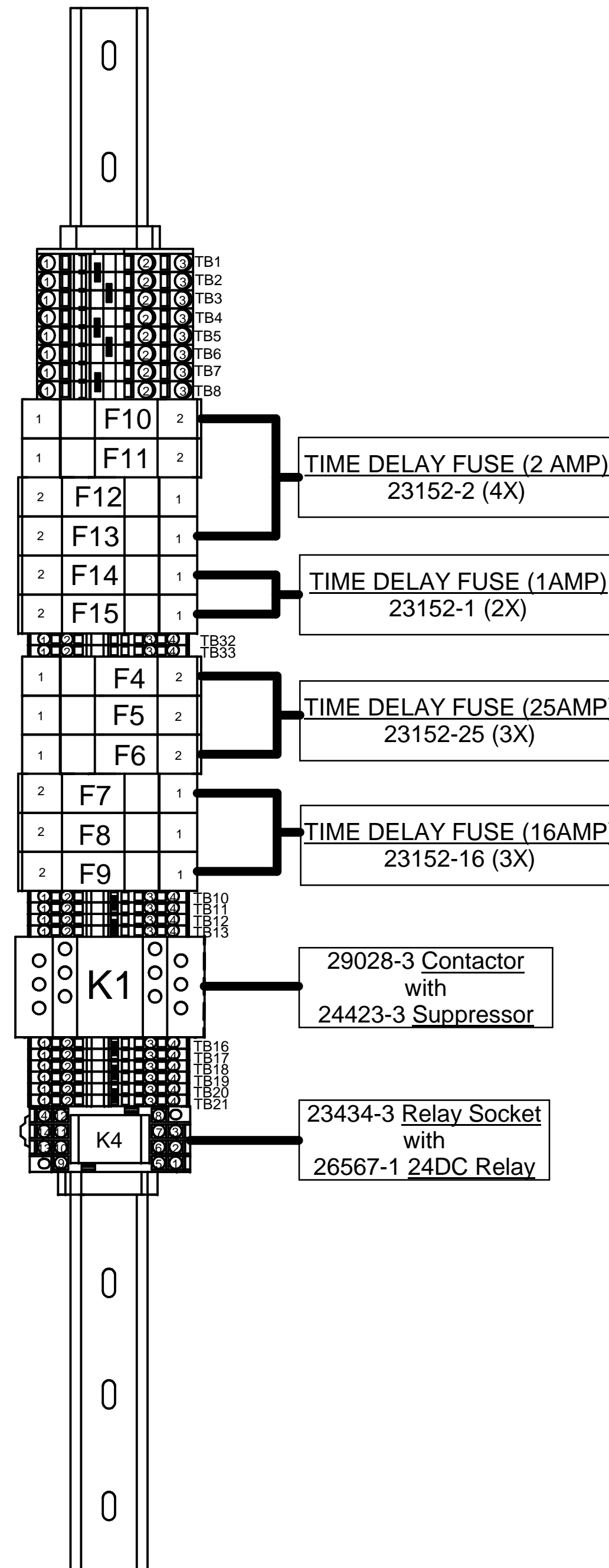

## DPMRX7:

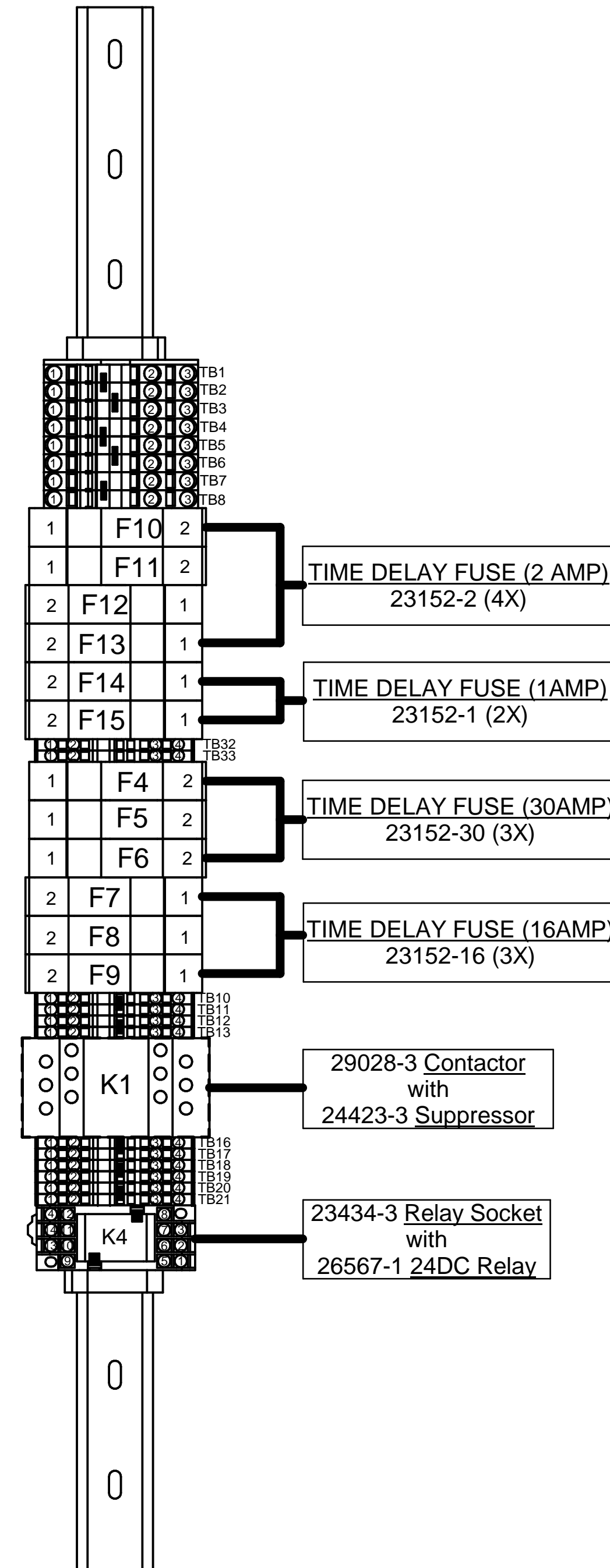



NOTICE: THIS DESIGN WAS ORIGINATED BY AND EMBODIES A CONFIDENTIAL PROPRIETARY DESIGN OWNED BY SOUTHWESTERN INDUSTRIES. IT IS DISCLOSED IN CONFIDENCE FOR A SPECIFIC PURPOSE AND THE RECIPIENT HEREOF AGREES NOT TO MAKE ANY REPRODUCTION, DISCLOSURE OR OTHER USE OF THIS INFORMATION WITHOUT THE WRITTEN CONSENT OF SOUTHWESTERN INDUSTRIES.  
© SOUTHWESTERN INDUSTRIES, INC. 2017 ALL RIGHT RESERVED

REVISIONS		ECN	DATE	DFT	ENG
REV	DESCRIPTION				
A	PRODUCTION RELEASE	14829	04/13/18	AC	LG

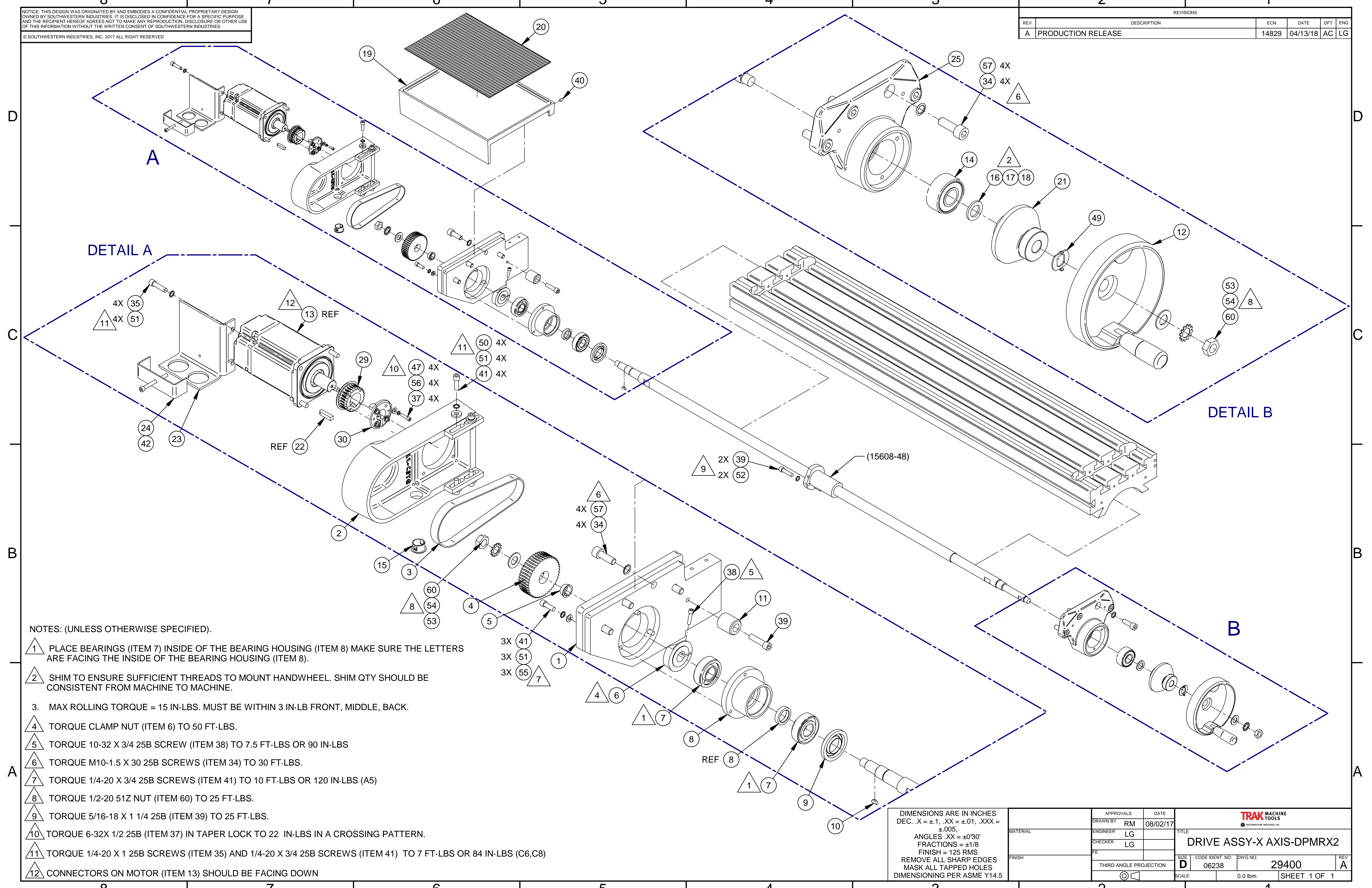

NOTES: (UNLESS OTHERWISE SPECIFIED).

- 1 PLACE BEARINGS (ITEM 7) INSIDE OF THE BEARING HOUSING (ITEM 8) MAKE SURE THE LETTERS ARE FACING THE INSIDE OF THE BEARING HOUSING (ITEM 8).
- 2 SHIM TO ENSURE SUFFICIENT THREADS TO MOUNT HANDWHEEL. SHIM QTY SHOULD BE CONSISTENT FROM MACHINE TO MACHINE.
- 3. MAX ROLLING TORQUE = 15 IN-LBS. MUST BE WITHIN 3 IN-LB FRONT, MIDDLE, BACK.
- 4 TORQUE CLAMP NUT (ITEM 6) TO 50 FT-LBS.
- 5 TORQUE 10-32 X 3/4 25B SCREW (ITEM 38) TO 7.5 FT-LBS OR 90 IN-LBS
- 6 TORQUE M10-1.5 X 30 25B SCREWS (ITEM 34) TO 30 FT-LBS.
- 7 TORQUE 1/4-20 X 3/4 25B SCREWS (ITEM 41) TO 10 FT-LBS OR 120 IN-LBS (A5)
- 8 TORQUE 1/2-20 51Z NUT (ITEM 60) TO 25 FT-LBS.
- 9 TORQUE 5/16-18 X 1 1/4 25B (ITEM 39) TO 25 FT-LBS.
- 10 TORQUE 6-32X 1/2 25B (ITEM 37) IN TAPER LOCK TO 22 IN-LBS IN A CROSSING PATTERN.
- 11 TORQUE 1/4-20 X 1 25B SCREWS (ITEM 35) AND 1/4-20 X 3/4 25B SCREWS (ITEM 41) TO 7 FT-LBS OR 84 IN-LBS (C6,C8)
- 12 CONNECTORS ON MOTOR (ITEM 13) SHOULD BE FACING DOWN

DIMENSIONS ARE IN INCHES  
DEC. .X = ±.1, .XX = ±.01, .XXX = ±.005,  
ANGLES .XX = ±0°30'  
FRACTIONS = ±1/8  
FINISH = 125 RMS  
REMOVE ALL SHARP EDGES  
MASK ALL TAPPED HOLES  
DIMENSIONING PER ASME Y14.5

APPROVALS		DATE	TITLE	
DRAWN BY	RM	08/02/17	DRIVE ASSY-X AXIS-DPMRX2	
ENGINEER	LG			
CHECKER	LG			
FINISH	THIRD ANGLE PROJECTION	SCALE: D	CODE IDENT. NO. 06238	DWG NO. 29400
			REV A	SHEET 1 OF 1

Parts List for Assembly P/N: 29400

Printed 4/26/2018

29400  
DRIVE ASSY-X AXIS-DPMRX2

Type	PL	Dwg Size	D
Revision	A	Product	DPMRX2
Status	R	Engineer	DSM
Date	4/27/2016	Planner Code	
By	DSM	Comm Code	

Item	P/N	Title	Detail	Reference(t)	Qty	UseAs	Rev	Stat
1	29410	END PLATE-X AXIS			1	EA	A	R
2	29411	BRACKET-MOTOR MOUNT-X AXIS-DPM2/3			1	EA	A	R
3	425-5M-15	BELT-TIMING 5MM POWERGRIP			1	EA	-	R
4	16983-1	PULLEY-SOLID 44 TEETH			1	EA	D	R
5	16350	FERRULE-SPROCKET-DRIVE KIT			1	EA	-	R
6	16452	NUT CLAMP-X, Y, & Z AXIS			1	EA	E	R
7	20373	BEARING-ANGULAR CONTACT-7204			2	EA	D	R
8	15612	BEARING HOUSING ASSY-X AXIS			1	EA	A	R
9	15626	SEAL-BEARING HOUSING			1	EA	A	R
10	98481A090	KEY WOODRUFF #404-1/8 X 1/2			1	EA	-	R
11	15638	STOP-STEEL-X AXIS			1	EA	D	R
12	29124	HANDWHEEL ASSY			1	EA	A	R
13	28164	MOTOR-BRUSHLESS-DELTA-750W	ECMA-C20807RS		(1)	EA	D	R
14	22008	BEARING-204KTT			1	EA	C	R
15	27348	PLUG-DOME PLUG-BLACK-PLASTIC-3/4			1	EA	A	R
16	14772	SPACER-CNC X AXIS HANDLE	.100" THICK		4	EA	B	R
17	14772-5	SPACER - .050" THICK			3	EA	B	R
18	14772-2	SPACER - .020" THICK			1	EA	B	R
19	29409	TRAY-DPM2 - MACHINED			1	EA	A	R
20	29496	RUBBER PAD - DPM2 TRAY			1	EA	A	R
21	29444	SPACER-HAND WHEEL-X AXIS-DPM2			1	EA	A	R

Item	P/N	Title	Detail	Reference(t)	Qty	UseAs	Rev	Stat
22	29433-1	KEY-80MM FRAME MOTOR			(1)	EA	A	R
23	29440-1	BRKT-CLAMP-MOTOR CONNECTOR			1	EA	A	R
24	29440-2	CLAMP-MOTOR CONNECTOR			1	EA	A	R
25	22007	END CAP-X AXIS FC006			(1)	EA	A	R
29	29430	PULLEY ASSY-26 TOOTH-15MM WIDE-19MM BORE			1	EA	A	R
30	29431-1	TAPER LOCK - 19MM BORE			1	EA	A	R
34	M10-1.5X30 25B	SCREW-SHCS-STL-BO			8	EA		R
35	1/4-20 X 1 25B	SCREW-SHCS-STL-BO			4	EA		R
37	6-32X5/8 25B	SCREW-SHCS-STL-BO			4	EA		R
38	10-32X3/4 25B	SCREW-SHCS-STL-BO			1	EA		R
39	5/16-18X1 1/4 25B	SCREW-SHCS-STL-BO			3	EA		R
40	1/4-28X3/8 42B	SCREW-SOC SET-STL-BO-CONE			1	EA	A	R
41	1/4-20 X 3/4 25B	SCREW-SHCS-STL-BO			7	EA		R
42	10-32X2 25B	SCREW-SHCS-STL-BO			1	EA		R
47	6 71B	WASHER-FLAT SAE-STL-BO			4	EA	A	R
49	15614	WASHER-TAB			1	EA	A	R
50	15759	WASHER-1/4 HARD BLK OX	.281 ID x .625 OD x .125 THK		4	EA	-	R
51	24009-3	WASHER-BELLEVILLE SPRING LK-SERRATED	.264 ID x .374 OD x .024 THK-1/4 or M6		11	EA	D	R
52	24009-1	WASHER-BELLEVILLE SPRING LK-SERRATED	.331 ID x .512 OD x .028 THK-5/16 or M8		2	EA	D	R
53	1/2 66Z	WASHER-FLAT-NARROW-ANSI TYPE B			2	EA	-	R
54	1/2 75Z	WASHER-EXT TOOTH-STL-ZINC			2	EA		R
55	M6 70B	WASHER-FLAT USS-STL-BO			3	EA	-	R
56	6 73B	WASHER-SPLIT LOCK-STL-BO			4	EA		R

Item	P/N	Title	Detail	Reference(t)	Qty	UseAs	Rev	Stat
57	24009-2	WASHER-BELLEVILLE SPRING LK-SERRATED	.413 ID x .630 OD x .036 THK-3/8 or M10		8	EA	D	R
60	1/2-20 51Z	NUT-HEX JAM-STL-ZINC			2	EA		R



NOTICE: THIS DESIGN WAS ORIGINATED BY AND EMBODIES A CONFIDENTIAL PROPRIETARY DESIGN OWNED BY SOUTHWESTERN INDUSTRIES. IT IS DISCLOSED IN CONFIDENCE FOR A SPECIFIC PURPOSE AND THE RECIPIENT HEREOF AGREES NOT TO MAKE ANY REPRODUCTION, DISCLOSURE OR OTHER USE OF THIS INFORMATION WITHOUT THE WRITTEN CONSENT OF SOUTHWESTERN INDUSTRIES.  
 © SOUTHWESTERN INDUSTRIES, INC. 2017 ALL RIGHT RESERVED

REVISIONS				
REV	DESCRIPTION	ECN	DATE	DFT ENG
A	PRODUCTION RELEASE	14829	04/13/18	AC LG

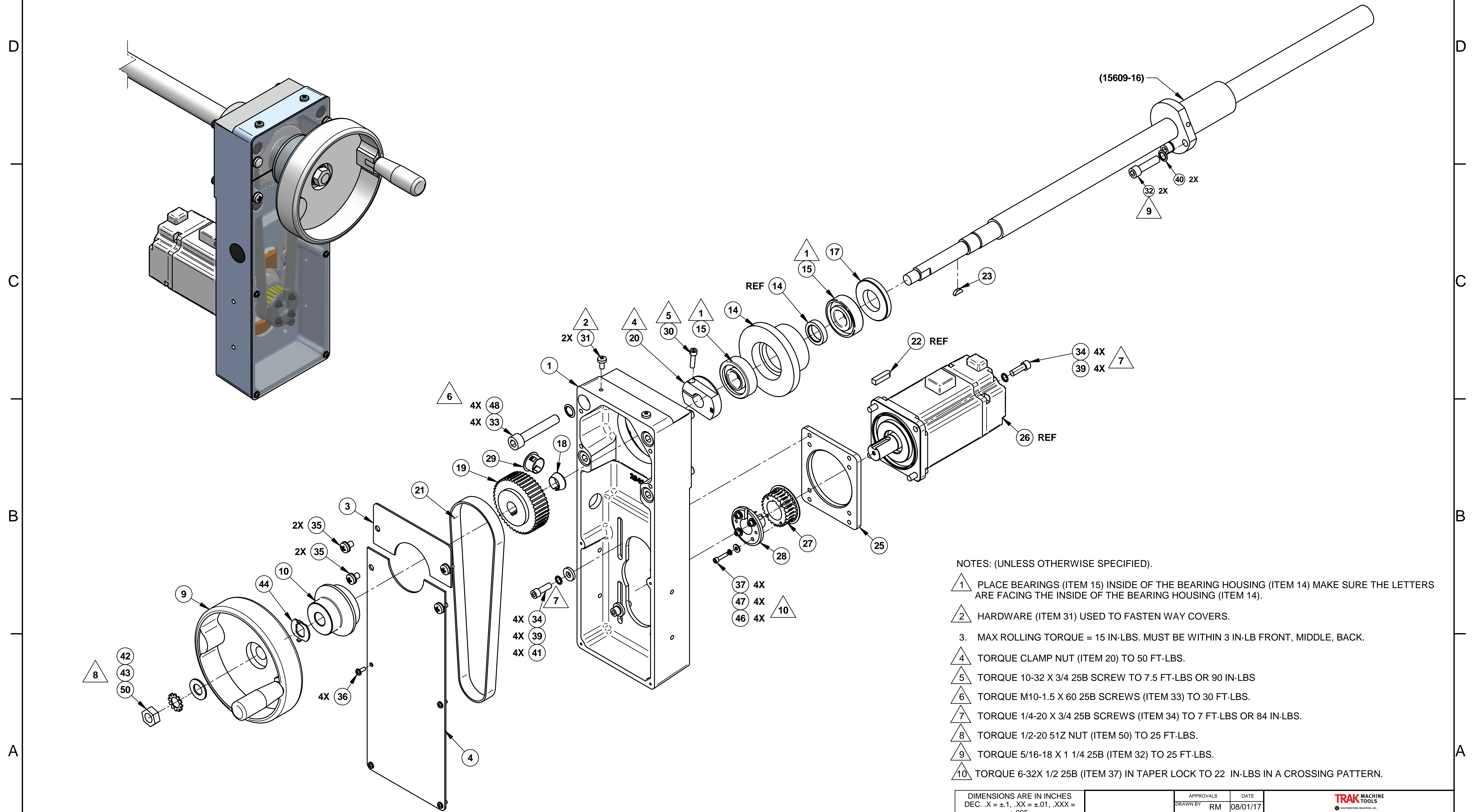

- NOTES: (UNLESS OTHERWISE SPECIFIED).
- 1 PLACE BEARINGS (ITEM 15) INSIDE OF THE BEARING HOUSING (ITEM 14) MAKE SURE THE LETTERS ARE FACING THE INSIDE OF THE BEARING HOUSING (ITEM 14).
  - 2 HARDWARE (ITEM 31) USED TO FASTEN WAY COVERS.
  - 3. MAX ROLLING TORQUE = 15 IN-LBS. MUST BE WITHIN 3 IN-LB FRONT, MIDDLE, BACK.
  - 4 TORQUE CLAMP NUT (ITEM 20) TO 50 FT-LBS.
  - 5 TORQUE 10-32 X 3/4 25B SCREW TO 7.5 FT-LBS OR 90 IN-LBS
  - 6 TORQUE M10-1.5 X 60 25B SCREWS (ITEM 33) TO 30 FT-LBS.
  - 7 TORQUE 1/4-20 X 3/4 25B SCREWS (ITEM 34) TO 7 FT-LBS OR 84 IN-LBS.
  - 8 TORQUE 1/2-20 51Z NUT (ITEM 50) TO 25 FT-LBS.
  - 9 TORQUE 5/16-18 X 1 1/4 25B (ITEM 32) TO 25 FT-LBS.
  - 10 TORQUE 6-32X 1/2 25B (ITEM 37) IN TAPER LOCK TO 22 IN-LBS IN A CROSSING PATTERN.

DIMENSIONS ARE IN INCHES DEC. X = ±.1, .XX = ±.01, .XXX = ±.005 ANGLES .XX = ±0'30' FRACTIONS = ±1/8 FINISH = 125 RMS REMOVE ALL SHARP EDGES MASK ALL TAPPED HOLES DIMENSIONING PER ASME Y14.5		APPROVALS DRAWN BY RM ENGINEER LG CHECKER LG DATE 08/01/17	TITLE <b>DRIVE ASSY-Y AXIS-DPMRX2/3</b>
MATERIAL	FINISH	THIRD ANGLE PROJECTION 	SIZE D CODE IDENT. NO. 06238 DWG NO. 29401 SCALE: 0.0 lbm SHEET 1 OF 1

Parts List for Assembly P/N: 29401

Printed 4/26/2018

29401  
DRIVE ASSY-Y AXIS-DPMRX2/3

Type	PL	Dwg Size	D
Revision	A	Product	DPMRX2
Status	R	Engineer	RM
Date	4/27/2016	Planner Code	
By	DSM	Comm Code	

Item	P/N	Title	Detail	Reference(t)	Qty	UseAs	Rev	Stat
1	29412	BRACKET-MOTOR MOUNT-X OR Y AXIS-DPM			1	EA	A	R
3	29415	COVER-UPPER			1	EA	A	R
4	29416	COVER-LOWER			1	EA	A	R
9	29124	HANDWHEEL ASSY			1	EA	A	R
10	29445	SPACER-HAND WHEEL-Y AXIS-DPM			1	EA	A	R
14	15980	BEARING HOUSING ASSY-LARGE FLANGE-Y AXIS			1	EA	B	R
15	20373	BEARING-ANGULAR CONTACT-7204			2	EA	D	R
17	15626	SEAL-BEARING HOUSING			1	EA	A	R
18	16350	FERRULE-SPROCKET-DRIVE KIT			1	EA	-	R
19	16983-1	PULLEY-SOLID 44 TEETH			1	EA	D	R
20	16452	NUT CLAMP-X, Y, & Z AXIS			1	EA	E	R
21	600-5M-15	BELT-TIMING			1	EA	-	R
22	29433-1	KEY-80MM FRAME MOTOR			(1)	EA	A	R
23	98481A090	KEY WOODRUFF #404-1/8 X 1/2			1	EA	-	R
25	29421	ADAPTER PLATE-750W BRUSHLESS MOTOR (80MM)			1	EA	A	R
26	28164	MOTOR-BRUSHLESS-DELTA-750W	ECMA-C20807RS		(1)	EA	D	R
27	29430	PULLEY ASSY-26 TOOTH-15MM WIDE-19MM BORE			1	EA	A	R
28	29431-1	TAPER LOCK - 19MM BORE			1	EA	A	R
29	27348	PLUG-DOME PLUG-BLACK-PLASTIC-3/4			1	EA	A	R
30	10-32X3/4 25B	SCREW-SHCS-STL-BO			1	EA		R

Item	P/N	Title	Detail	Reference(t)	Qty	UseAs	Rev	Stat
31	M5-0.8X10 10Z	SCREW-PH-PHIL-STL-ZINC			2	EA	-	R
32	5/16-18X1 1/4 25B	SCREW-SHCS-STL-BO			2	EA		R
33	M10-1.5X60 25B	SCREW-SHCS-STL-BO			4	EA		R
34	1/4-20X3/4 25B	SCREW-SHCS-STL-BO			8	EA	A	R
35	1/4-20X3/8 31Z	SCREW-PH-PHIL-EXT SEMS-STL-ZINC			4	EA	-	R
36	6-32X3/8 31Z	SCREW-PH-PHIL-EXT SEMS-STL-ZINC			4	EA	A	R
37	6-32X5/8 25B	SCREW-SHCS-STL-BO			4	EA		R
39	24009-3	WASHER-BELLEVILLE SPRING LK-SERRATED	.264 ID x .374 OD x .024 THK-1/4 or M6		8	EA	D	R
40	24009-1	WASHER-BELLEVILLE SPRING LK-SERRATED	.331 ID x .512 OD x .028 THK-5/16 or M8		2	EA	D	R
41	15759	WASHER-1/4 HARD BLK OX	.281 ID x .625 OD x .125 THK		4	EA	-	R
42	1/2 66Z	WASHER-FLAT-NARROW-ANSI TYPE B			1	EA	-	R
43	1/2 75Z	WASHER-EXT TOOTH-STL-ZINC			1	EA		R
44	15614	WASHER-TAB			1	EA	A	R
46	6 71B	WASHER-FLAT SAE-STL-BO			4	EA	A	R
47	6 73B	WASHER-SPLIT LOCK-STL-BO			4	EA		R
48	24009-2	WASHER-BELLEVILLE SPRING LK-SERRATED	.413 ID x .630 OD x .036 THK-3/8 or M10		4	EA	D	R
50	1/2-20 51Z	NUT-HEX JAM-STL-ZINC			1	EA		R



NOTICE: THIS DESIGN WAS ORIGINATED BY AND EMBODIES A CONFIDENTIAL PROPRIETARY DESIGN OWNED BY SOUTHWESTERN INDUSTRIES. IT IS DISCLOSED IN CONFIDENCE FOR A SPECIFIC PURPOSE AND THE RECIPIENT HEREOF AGREES NOT TO MAKE ANY REPRODUCTION, DISCLOSURE OR OTHER USE OF THIS INFORMATION WITHOUT THE WRITTEN CONSENT OF SOUTHWESTERN INDUSTRIES.

© SOUTHWESTERN INDUSTRIES, INC. 2016 ALL RIGHT RESERVED

REVISIONS				
REV	DESCRIPTION	ECN	DATE	DFT ENG
A	PRODUCTION RELEASE	14829	04/13/18	AC LG

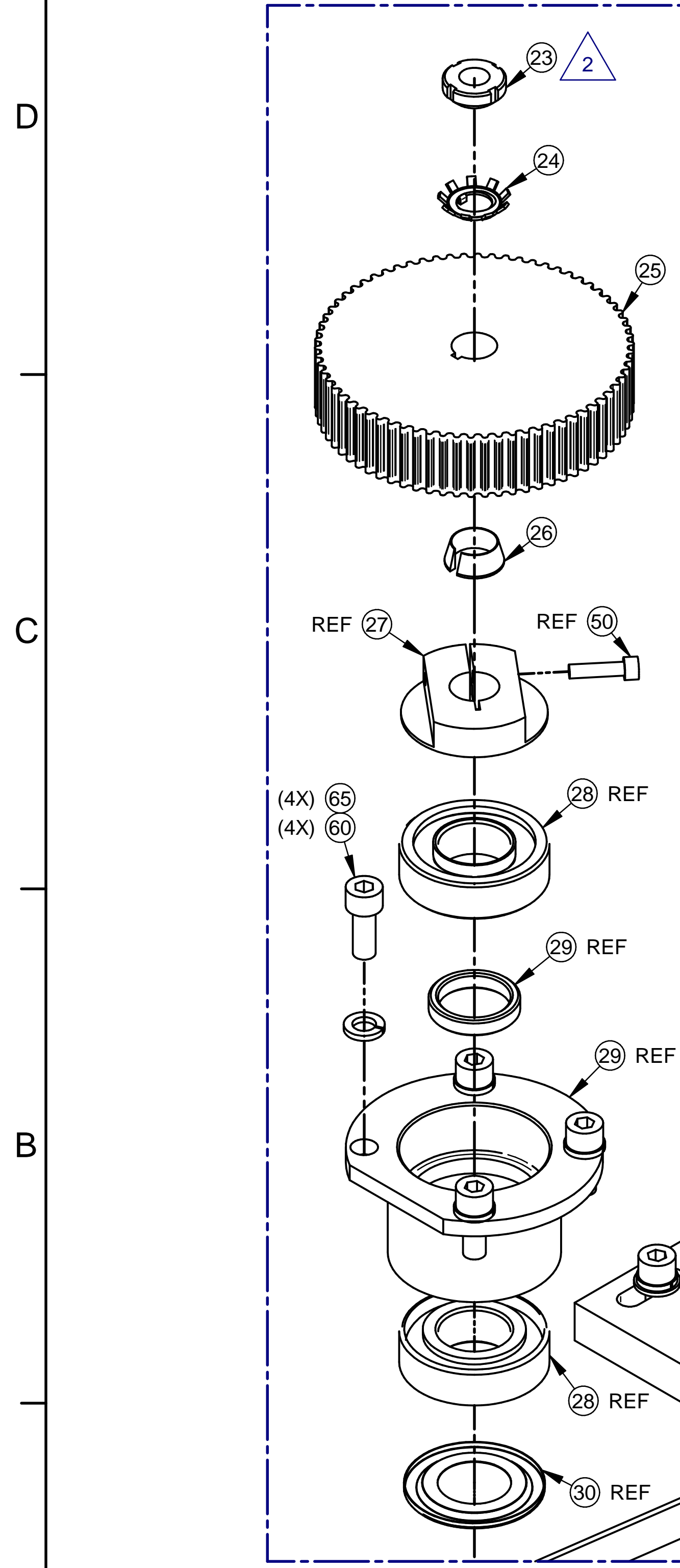

DETAIL A

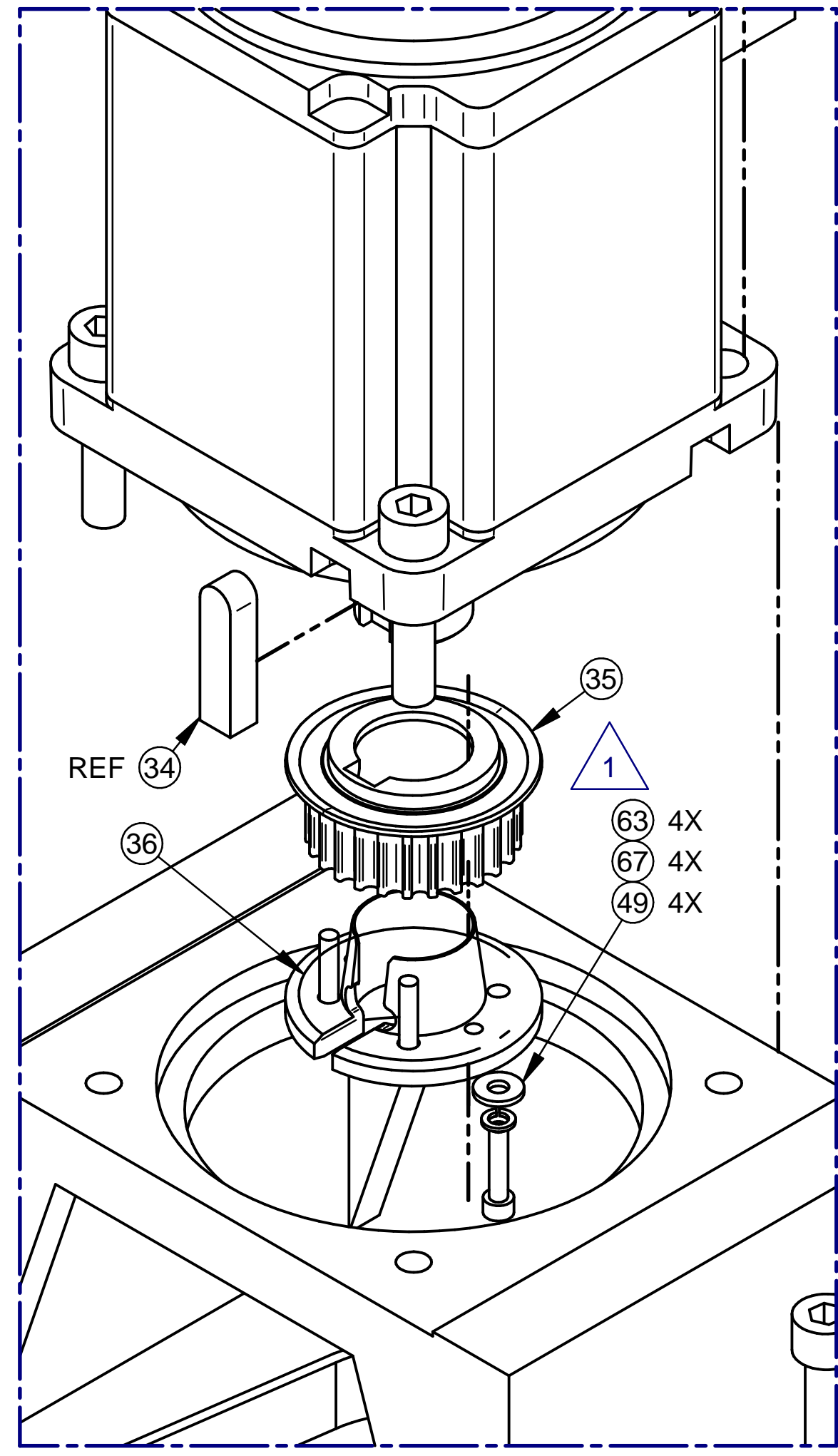
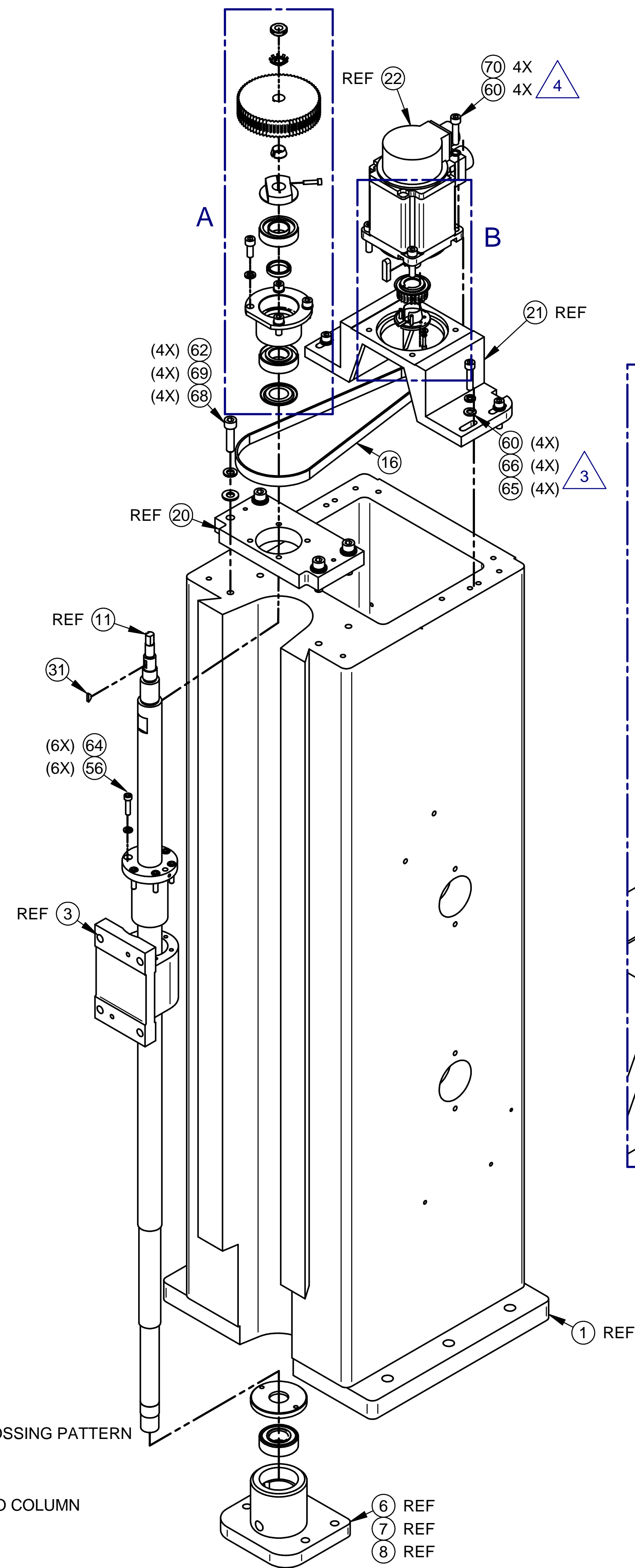

DETAIL B

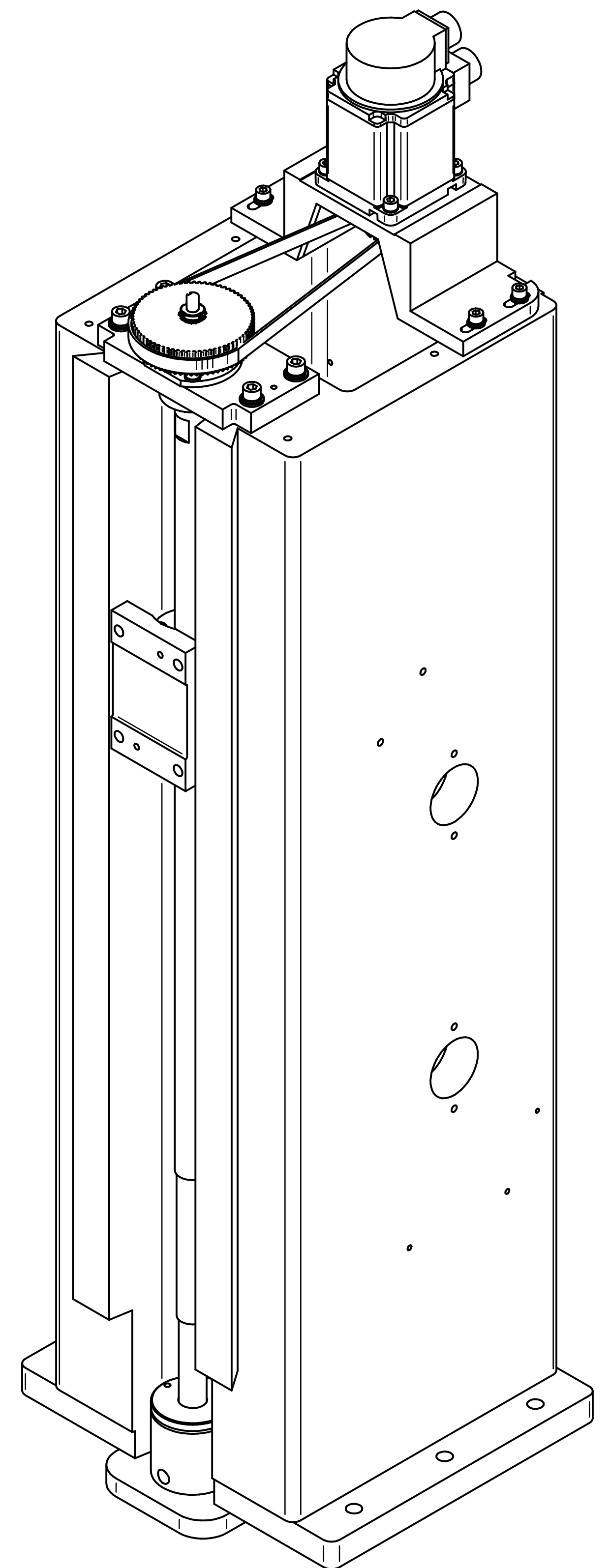

NOTES: (UNLESS OTHERWISE SPECIFIED)

- 1 TORQUE 6-32X 1/2 25B (ITEM 37) IN TAPER LOCK TO 22 IN-LBS IN A CROSSING PATTERN
- 2 TORQUE NO1 (ITEM 23) SCREW TO 20 FT-LBS
- 3 TORQUE M8-1.25X25 25B (ITEM 60) SCREWS FROM MOTOR BRACKET TO COLUMN TO 30 FT-LBS
- 4 TORQUE M8-1.25X25 25B (ITEM 60) SCREWS TO 7 FT-LBS

DIMENSIONS ARE IN INCHES DEC. X = ±.1, .XX = ±.01, .XXX = ±.005, ANGLES .XX = ±0°30'		APPROVALS	DATE	TRAK MACHINE TOOLS	
FINISH = 125 RMS REMOVE ALL SHARP EDGES MASK ALL TAPPED HOLES DIMENSIONING PER ASME Y14.5		DRAWN BY RM	01/27/16	SHEET 1 OF 1	
THIRD ANGLE PROJECTION		ENGINEER LG		TITLE DRIVE ASSY-Z AXIS-DPMRX2	
		CHECKER LG		SIZE D	CODE IDENT. NO. 06238
				DWG NO. 29402	REV A
				SCALE: NA	



Parts List for Assembly P/N: 29402

Printed 4/13/2018

29402  
DRIVE ASSY-Z AXIS-DPMRX2

Type	PL	Dwg Size	D
Revision	A	Product	DPMRX2
Status	R	Engineer	RM
Date	12/4/2015	Planner Code	
By	Rogelio	Comm Code	

Item	P/N	Title	Detail	Reference(t)	Qty	UseAs	Rev	Stat	Type
1	23613	COLUMN-DPM2	LM0009		(1)	EA	1	R	PS
3	23657	YOKE-Z AXIS-DPM2	LM0039		(1)	EA	A	R	PS
6	PJ540015	BRACKET LOWER ELEVATING BALL SCREW			(1)	EA		R	PS
7	22583	BEARING-SELF ALIGNING 2205E-2RS1TN9			(1)	EA	A	R	DWG
8	16774	PROTECTOR-BEARING			(1)	EA	-	R	DWG
11	23662	BALLSCREW-Z AXIS	LM0010		(1)	EA	A	R	PS
16	755-5MHP-15	BELT - TIMING 5MM OMEGA HP			1	EA	A	R	PS
20	23664	BRACKET-Z AXIS BALLSCREW-DPME2	LM0011		(1)	EA	-	R	DWG
21	29883-2	BRACKET-MOTOR MOUNT -Z AXIS-DPM2			(1)	EA	A	R	DWG
22	28164-1	MOTOR-BRUSHLESS-DELTA-1KW	ECMA-C21010RS		(1)	EA	B	R	DWG
23	N01	LOCKNUT			1	EA		R	PS
24	W01	LOCKWASHER			1	EA		R	PS
25	29881	PULLEY-BALLSCREW-70 TOOTH			1	EA	A	R	DWG
26	16350	FERRULE-SPROCKET-DRIVE KIT			1	EA	-	R	DWG
27	16773	NUT CLAMP-Z AXIS			(1)	EA	C	R	DWG
28	20374	BEARING-ANGULAR CONTACT-7205	FOR REPL SEE 23940		(2)	EA	G	R	DWG
29	16295-1	HOUSING-BEARING ASSY-Z AXIS			(1)	EA	B	R	PL
30	7204-AVH	NILOS RING-7204			(1)	EA		R	PS
31	98481A090	KEY WOODRUFF #404-1/8 X 1/2			1	EA	-	R	PS
34	29433-2	KEY-100MM FRAME MOTOR			(1)	EA		R	PS

Item	P/N	Title	Detail	Reference(t)	Qty	UseAs	Rev	Stat	Type
35	29434	PULLEY ASSY-26 TOOTH-15MM WIDE-22MM BORE			1	EA	A	R	PL
36	29431-2	TAPER LOCK - 22MM BORE			1	EA	A	R	PS
49	6-32X5/8 25B	SCREW-SHCS-STL-BO			4	EA		R	PS
50	10-32X3/4 25B	SCREW-SHCS-STL-BO			(1)	EA		R	PS
56	M6-1.0X25 25B	SCREW-SHCS-STL-BO			(6)	EA	A	R	PS
60	M8-1.25X35 25B	SCREW-SHCS-STL-BO			4	EA		R	PS
62	M10-1.5X40 25B	SCREW-SHCS-STL-BO			(4)	EA		R	PS
63	6 71B	WASHER-FLAT SAE-STL-BO			4	EA	A	R	PS
64	M6 73B	WASHER-SPLIT LOCK-STL-BO			(6)	EA	-	R	PS
65	M8 73B	WASHER-SPLIT LOCK-STL-BO			(8)	EA		R	PS
66	M8 70B	WASHER-FLAT USS-STL-BO			(4)	EA		R	PS
67	6 73B	WASHER-SPLIT LOCK-STL-BO			4	EA		R	PS
68	M10 73B	WASHER-SPLIT LOCK-STL-BO			(4)	EA	-	R	PS
69	M10 71B	WASHER-FLAT SAE-STL-BO			(4)	EA	-	R	PS
70	24009-1	WASHER-BELLEVILLE SPRING LK-SERRATED	.331 ID x .512 OD x .028 THK-5/16 or M8		4	EA	D	R	DWG



REVISION TABLE					
REV	REV DESCRIPTION	ECN/NPI#	DATE	DFT	ENG
A	PRODUCTION RELEASE	ECN-14888	07/20/18	AC	LG
B	REMOVED 29440-2. ADDED 29440-5, 29440-6.	ECN-16276	11-22-21	JM	JJ

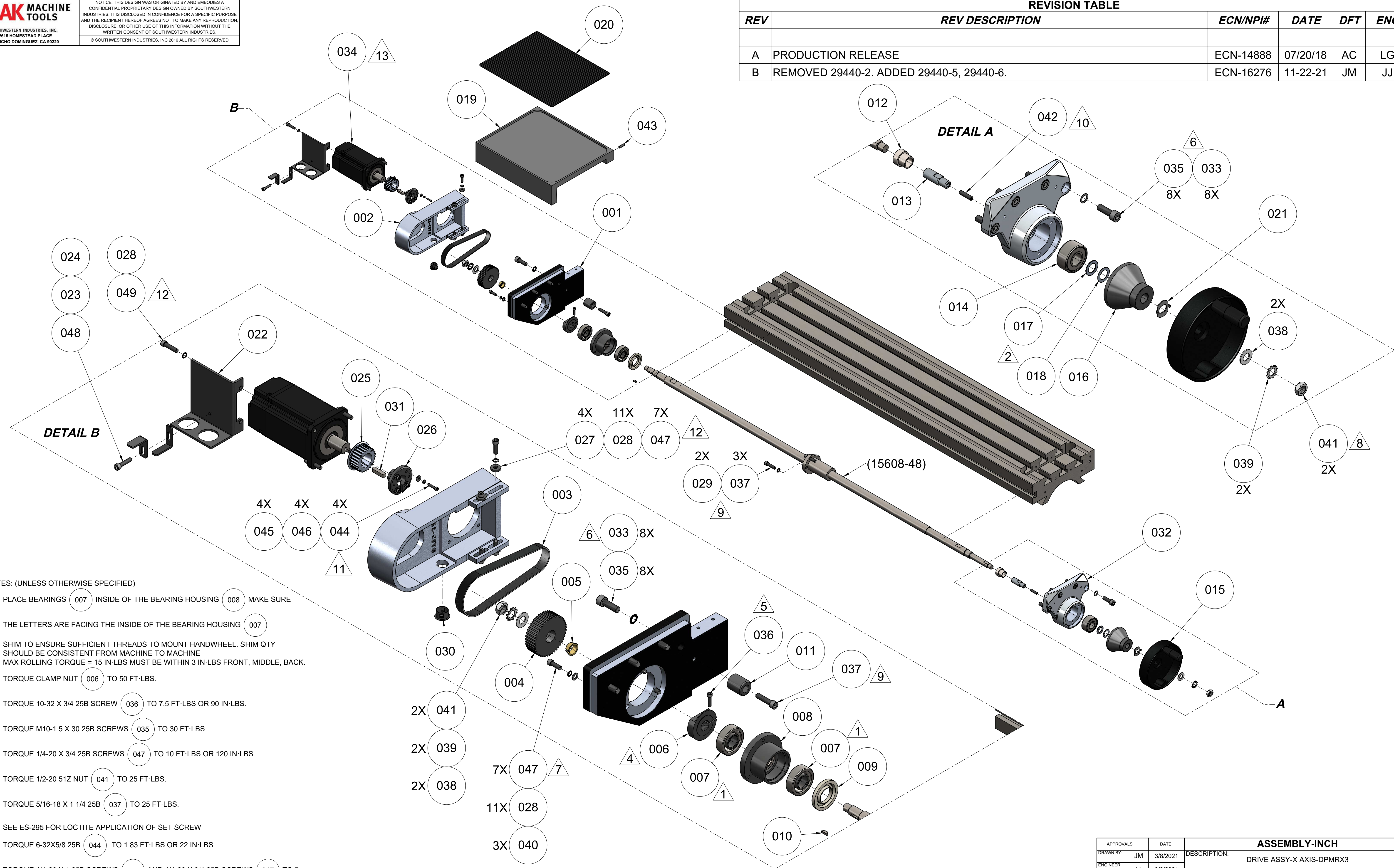

- NOTES: (UNLESS OTHERWISE SPECIFIED)
- ▲ PLACE BEARINGS (007) INSIDE OF THE BEARING HOUSING (008) MAKE SURE THE LETTERS ARE FACING THE INSIDE OF THE BEARING HOUSING (007)
  - ▲ SHIM TO ENSURE SUFFICIENT THREADS TO MOUNT HANDWHEEL. SHIM QTY SHOULD BE CONSISTENT FROM MACHINE TO MACHINE
  - 3. MAX ROLLING TORQUE = 15 IN-LBS MUST BE WITHIN 3 IN-LBS FRONT, MIDDLE, BACK.
  - ▲ TORQUE CLAMP NUT (006) TO 50 FT-LBS.
  - ▲ TORQUE 10-32 X 3/4 25B SCREW (036) TO 7.5 FT-LBS OR 90 IN-LBS.
  - ▲ TORQUE M10-1.5 X 30 25B SCREWS (035) TO 30 FT-LBS.
  - ▲ TORQUE 1/4-20 X 3/4 25B SCREWS (047) TO 10 FT-LBS OR 120 IN-LBS.
  - ▲ TORQUE 1/2-20 51Z NUT (041) TO 25 FT-LBS.
  - ▲ TORQUE 5/16-18 X 1 1/4 25B (037) TO 25 FT-LBS.
  - ▲ SEE ES-295 FOR LOCTITE APPLICATION OF SET SCREW
  - ▲ TORQUE 6-32X5/8 25B (044) TO 1.83 FT-LBS OR 22 IN-LBS.
  - ▲ TORQUE 1/4-20 X 1 25B SCREWS (049) AND 1/4-20 X 3/4 25B SCREWS (047) TO 7 FT-LBS OR 84 IN-LBS (C5,C7)
  - ▲ MOTOR CONNECTORS ON MOTOR SHOULD BE FACING DOWN.

APPROVALS	DATE	<b>ASSEMBLY-INCH</b>	
DRAWN BY: JM	3/8/2021	DESCRIPTION: DRIVE ASSY-X AXIS-DPMRX3	
ENGINEER: JJ	3/8/2021	PART NUMBER: 29403	
MASS (LBS):		DETAIL:	
THIRD ANGLE PROJECTION		REV: B	SIZE: D SHEET: 1 OF 3



PART NUMBER:	DRAWN BY: JM	3/8/2021	
29403	ENGINEER: JJ	3/8/2021	

Item No.	Part Number	Description	Detail	Type	QTY.	Item Length	Category	MFG Part Number	Manufacturer
001	29410	END PLATE - X AXIS		Normal	1				
002	29411	BRACKET-MOTOR MOUNT-X AXIS-DPM2/3		Normal	1		Manufactured		
003	425-5M-15	BELT-TIMING 5MM POWERGRIP		Normal	1		Purchased		
004	16983-1	PULLEY-SOLID 44 TEETH		Normal	1		Manufactured		
005	16350	FERRULE-SPROCKET-DRIVE KIT		Normal	1				
006	16452	NUT CLAMP-X, Y, & Z AXIS		Normal	1				
007	20373	BEARING-ANGULAR CONTACT-7204		Normal	2		Purchased	7204BMUCSMYP6	NACHI
008	15612	BEARING HOUSING ASSY-X AXIS		Normal	1		Manufactured		
009	15626	SEAL-BEARING HOUSING		Normal	1				
010	98481A090	KEY WOODRUFF #404-1/8 X 1/2		Normal	1		Purchased		
011	15638	STOP-X AXIS		Normal	1				
012	15058-.875	BUSHING-BALLSCREW EXTENSION		Normal	1		Manufactured		
013	15180	SHAFT EXTENSION-1IN		Normal	1		Manufactured		
014	22008	BEARING-204KTT		Normal	1		Purchased	204KTT	Timken
015	29124	HANDWHEEL ASSY		Normal	1				
016	29452	SPACER-HANDWHEEL X AXIS-DPM3		Normal	1		Manufactured		
017	14772-5	SPACER - .050" THICK		Normal	1		Manufactured		
018	14772-2	SPACER - .020" THICK		Normal	1		Manufactured		
019	22069	TRAY-DPMV3		Normal	1		Manufactured		
020	15977	RUBBER PAD-X AXIS		Normal	1		Manufactured		
021	15614	WASHER-TAB		Normal	1		Purchased		
022	29440-1	BRACKET-CLAMP-MOTOR CONNECTOR		Normal	1		Purchased		
023	29440-5	CLAMP-UPPER-MOTOR CONNECTOR		Normal	1		Manufactured		
024	29440-6	CLAMP-LOWER-MOTOR CONNECTOR		Normal	1		Manufactured		
025	29430	PULLEY ASSY-26 TOOTH-15MM WIDE-19MM BORE		Normal	1		Manufactured		
026	29431-1	TAPER LOCK-19MM BORE		Normal	1				
027	15759	WASHER-1/4 HARD BLK OX	.281 ID X .625 OD X .125 THK	Normal	4		Manufactured		
028	24009-3	WASHER-BELLEVILLE SPRING LK-SERRATED	.264 ID X .374 OD X .024 THK-1/4 OR M6	Normal	11		Purchased	WSPESTL025N037P L028S	ATLAS BOLT
029	24009-1	WASHER-BELLEVILLE SPRING LK-SERRATED	.331 ID X .512 OD X .028 THK-5/16 OR M8	Normal	2		Purchased	WSPESTL031N051P L031S	ATLAS BOLT
030	27348	PLUG-DOME PLUG-BLACK-PLASTIC-3/4		Normal	1		Purchased		
031	29433-1	KEY-80MM FRAME MOTOR		Normal	1		Manufactured		

PRODUCTS USED ON:

REV: **B** SHEET: **2** OF **3**

PART NUMBER: 29403	DRAWN BY: JM	3/8/2021							
	ENGINEER: JJ	3/8/2021							

Item No.	Part Number	Description	Detail	Type	QTY.	Item Length	Category	MFG Part Number	Manufacturer
032	22007	END CAP-X AXIS-FC006		Normal	1		Purchased	FC006	Ping Jeng
033	24009-2	WASHER-BELLEVILLE SPRING LK-SERRATED	.413 ID X .630 OD X .036 THK-3/8 OR M10	Normal	8		Purchased		
034	28164	MOTOR-BRUSHLESS-DELTA-750W		Normal	1		Purchased	ECMA-C20807RS-MS2	Delta
035	M10-1.5X30 (25B)	SCREW-SHCS-STL-BO	STOCKED	Normal	8		Purchased		
036	10-32X3/4 (25B)	SCREW-SHCS-STL-BO	STOCKED	Normal	1		Purchased		
037	5/16-18X1-1/4 (25B)	SCREW-SHCS-STL-BO	STOCKED	Normal	3		Purchased		
038	1/2 66Z	WASHER-FLAT-NARROW-ANSI TYPE B		Normal	2		Purchased		
039	1/2 75Z	WASHER-EXT TOOTH-STL-ZINC		Normal	2		Purchased		
040	M6 (70B)	WASHER-FLAT USS-STL-BO	STOCKED	Normal	3		Purchased		
041	1/2-20 51Z	NUT-HEX JAM-STL-ZINC		Normal	2		Purchased		
042	1/4-28X1 (43B)	SCREW-SOC SET-STL-BO-KNURLED		Normal	1		Purchased		
043	1/4-28X3/4 (42B)	SCREW-SOC SET-STL-BO-CONE		Normal	1		Purchased		
044	6-32X5/8 (25B)	SCREW-SHCS-STL-BO	STOCKED	Normal	4		Purchased		
045	6 (71B)	WASHER-FLAT SAE-STL-BO		Normal	4		Purchased		
046	6 (73B)	WASHER-SPLIT LOCK-STL-BO	STOCKED	Normal	4		Purchased		
047	1/4-20X3/4 (25B)	SCREW-SHCS-STL-BO	STOCKED	Normal	7		Purchased		
048	M6-1.0X25 (25B)	SCREW-SHCS-STL-BO	STOCKED	Normal	1		Purchased		
049	1/4-20X1 (25B)	SCREW-SHCS-STL-BO	STOCKED	Normal	4		Purchased		

NOTICE: THIS DESIGN WAS ORIGINATED BY AND EMBODIES A CONFIDENTIAL PROPRIETARY DESIGN OWNED BY SOUTHWESTERN INDUSTRIES. IT IS DISCLOSED IN CONFIDENCE FOR A SPECIFIC PURPOSE AND THE RECIPIENT HEREOF AGREES NOT TO MAKE ANY REPRODUCTION, DISCLOSURE OR OTHER USE OF THIS INFORMATION WITHOUT THE WRITTEN CONSENT OF SOUTHWESTERN INDUSTRIES.

© SOUTHWESTERN INDUSTRIES, INC. 2017 ALL RIGHT RESERVED

REVISIONS				
REV	DESCRIPTION	ECN	DATE	DFT ENG
A	PRODUCTION RELEASE.	14879	06/27/18	AC LG

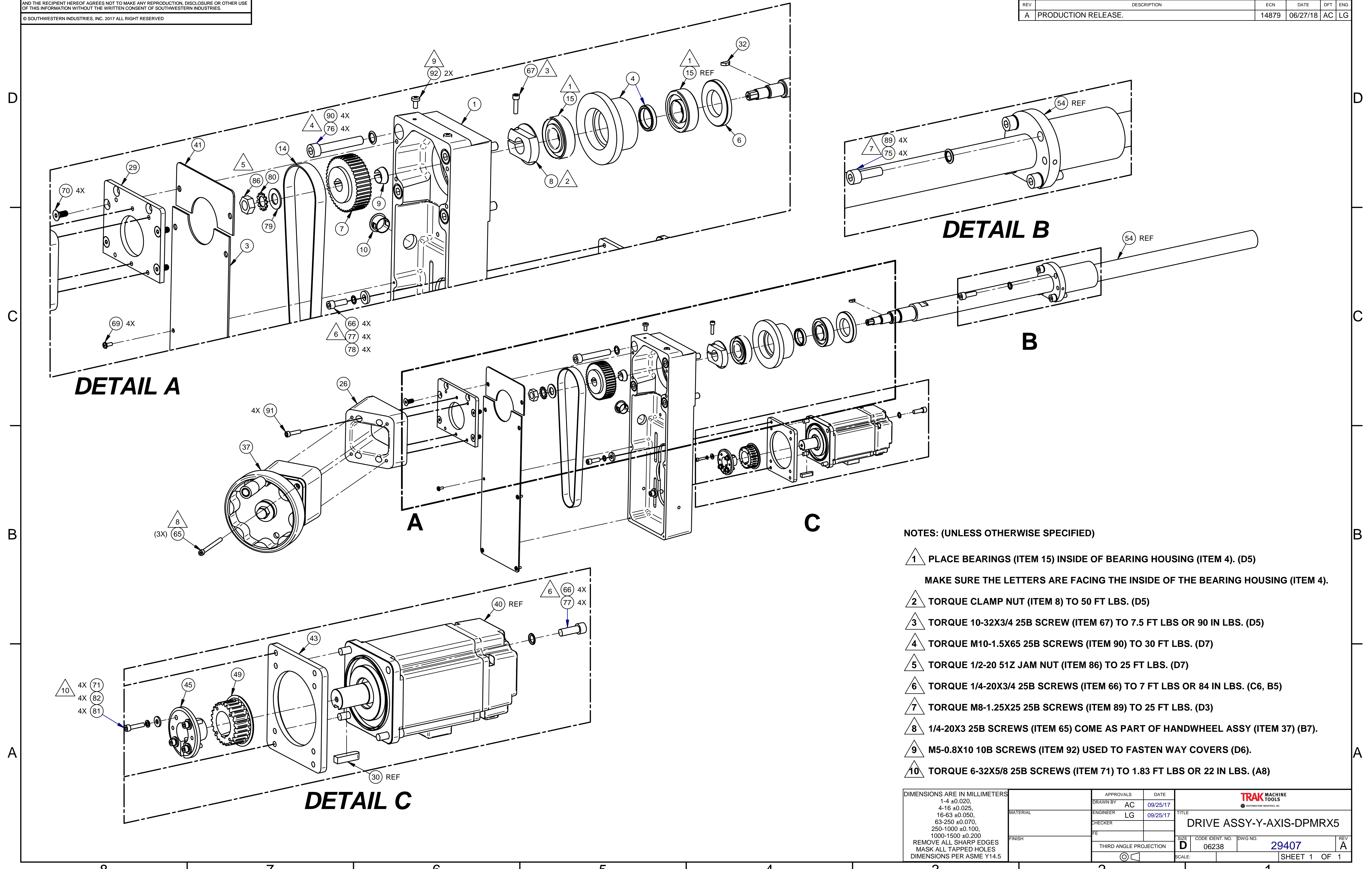

**DETAIL A**

**DETAIL B**

**DETAIL C**

- NOTES: (UNLESS OTHERWISE SPECIFIED)**
- ▲ 1 PLACE BEARINGS (ITEM 15) INSIDE OF BEARING HOUSING (ITEM 4). (D5)  
MAKE SURE THE LETTERS ARE FACING THE INSIDE OF THE BEARING HOUSING (ITEM 4).
  - ▲ 2 TORQUE CLAMP NUT (ITEM 8) TO 50 FT LBS. (D5)
  - ▲ 3 TORQUE 10-32X3/4 25B SCREW (ITEM 67) TO 7.5 FT LBS OR 90 IN LBS. (D5)
  - ▲ 4 TORQUE M10-1.5X65 25B SCREWS (ITEM 90) TO 30 FT LBS. (D7)
  - ▲ 5 TORQUE 1/2-20 51Z JAM NUT (ITEM 86) TO 25 FT LBS. (D7)
  - ▲ 6 TORQUE 1/4-20X3/4 25B SCREWS (ITEM 66) TO 7 FT LBS OR 84 IN LBS. (C6, B5)
  - ▲ 7 TORQUE M8-1.25X25 25B SCREWS (ITEM 89) TO 25 FT LBS. (D3)
  - ▲ 8 1/4-20X3 25B SCREWS (ITEM 65) COME AS PART OF HANDWHEEL ASSY (ITEM 37) (B7).
  - ▲ 9 M5-0.8X10 10B SCREWS (ITEM 92) USED TO FASTEN WAY COVERS (D6).
  - ▲ 10 TORQUE 6-32X5/8 25B SCREWS (ITEM 71) TO 1.83 FT LBS OR 22 IN LBS. (A8)

DIMENSIONS ARE IN MILLIMETERS 1-4 ±0.020, 4-16 ±0.025, 16-63 ±0.050, 63-250 ±0.070, 250-1000 ±0.100, 1000-1500 ±0.200 REMOVE ALL SHARP EDGES MASK ALL TAPPED HOLES DIMENSIONS PER ASME Y14.5		APPROVALS DRAWN BY AC 09/25/17 ENGINEER LG 09/25/17 CHECKER FE	DATE 09/25/17 09/25/17	TITLE <b>DRIVE ASSY-Y-AXIS-DPMRX5</b>
MATERIAL	FINISH	THIRD ANGLE PROJECTION	SCALE:	SIZE <b>D</b> CODE IDENT. NO. 06238 DWG NO. 29407 REV A
SHEET 1 OF 1				

Parts List for Assembly P/N: 29407

Printed 6/27/2018

29407  
DRIVE ASSY - Y-AXIS - DPMRX5

Type	PL	Dwg Size	D
Revision	A	Product	
Status	R	Engineer	AC
Date	2/2/2017	Planner Code	
By	AC	Comm Code	MANUF

Item	P/N	Title	Detail	Reference(t	Qty	UseAs	Rev	Stat	Type	Mfr	Mfr P/N
1	29412	BRACKET-MOTOR MOUNT-X OR Y AXIS-DPM			1	EA	A	R	PL		
3	29416	COVER-LOWER			1	EA	A	R	DWG		
4	21662	BEARING HOUSING ASSY			1	EA	B	R	PL		
6	16078	SEAL-BEARING			1	EA	-	R	DWG		
7	16983-1	PULLEY-SOLID 44 TEETH			1	EA	D	R	DWG		
8	16066	NUT CLAMP-X & Y AXIS			1	EA	E	R	DWG		
9	16350	FERRULE-SPROCKET-DRIVE KIT			1	EA	-	R	DWG		
10	27348	PLUG-DOME PLUG-BLACK-PLASTIC-3/4			1	EA	A	R	DWG	HEYCO	2643
14	600-5M-15	BELT-TIMING			1	EA	-	R	PS	GATES	600-5M-15
15	23940	BEARING-ANGULAR CONTACT-U/SET (2)-7205			1	EA	A	R	PL		
26	21985	SPACER ANGLED 30 DEGREE Y-AXIS			1	EA	E	R	PL		
29	21984	BRACKET - WAY COVER FRONT Y-AXIS DRIVE			1	EA	F	R	DWG		
30	29433-1	KEY-80MM FRAME MOTOR			(1)	EA	A	R	PS		
32	98481A090	KEY WOODRUFF #404-1/8 X 1/2			1	EA	-	R	PS		
37	21946	ELEC HANDWHEEL-X & Y AXIS			1	EA	K	R	PL		
39	22768-37	LABEL-TEXT-WHITE-1.00W x 1.437H	EHW Y		1	EA	AC	R	DWG		
40	28164	MOTOR-BRUSHLESS-DELTA-750W	ECMA-C20807 RS		(1)	EA	D	R	PL		
41	29415	COVER-UPPER			1	EA	A	R	DWG		
43	29421	ADAPTER PLATE-750W BRUSHLESS MOTOR (80MM)			1	EA	A	R	DWG		

Item	P/N	Title	Detail	Reference(t	Qty	UseAs	Rev	Stat	Type	Mfr	Mfr P/N
45	29431-1	TAPER LOCK - 19MM BORE			1	EA	A	R	PS		
49	29430	PULLEY ASSY-26 TOOTH-15MM WIDE-19MM BORE			1	EA	A	R	PL		
54	21565	BALLSCREW-Y AXIS LEFT HAND LEAD 5HP DPM			(1)	EA	B	R	DWG		
65	1/4-20X3 25B	SCREW-SHCS-STL-BO			(3)	EA		R	PS		
66	1/4-20X3/4 25B	SCREW-SHCS-STL-BO			8	EA	A	R	PS		
67	10-32X3/4 25B	SCREW-SHCS-STL-BO			1	EA		R	PS		
69	6-32X3/8 31Z	SCREW-PH-PHIL-EXT SEMS-STL-ZINC			4	EA	A	R	PS		
70	1/4-20X5/8 26B	SCREW-FHCS-STL-BO			4	EA		R	PS		
71	6-32X5/8 25B	SCREW-SHCS-STL-BO			4	EA		R	PS		
75	24009-1	WASHER-BELLEVILLE SPRING LK-SERRATED	.331 ID x .512 OD x .028 THK-5/16 or M8		4	EA	D	R	DWG		
76	24009-2	WASHER-BELLEVILLE SPRING LK-SERRATED	.413 ID x .630 OD x .036 THK-3/8 or M10		4	EA	D	R	DWG		
77	24009-3	WASHER-BELLEVILLE SPRING LK-SERRATED	.264 ID x .374 OD x .024 THK-1/4 or M6		8	EA	D	R	DWG		
78	15759	WASHER-1/4 HARD BLK OX	.281 ID x .625 OD x .125 THK		4	EA	-	R	DWG		
79	1/2 66Z	WASHER-FLAT-NARROW-ANSI TYPE B			1	EA	-	R	PS		
80	1/2 75Z	WASHER-EXT TOOTH-STL-ZINC			1	EA		R	PS		
81	6 71B	WASHER-FLAT SAE-STL-BO			4	EA	A	R	PS		
82	6 73B	WASHER-SPLIT LOCK-STL-BO			4	EA		R	PS		
86	1/2-20 51Z	NUT-HEX JAM-STL-ZINC			1	EA		R	PS		
89	M8-1.25X25 25B	SCREW-SHCS-STL-BO			4	EA		R	PS		
90	M10-1.5X65 25B	SCREW-SHCS-STL-BO			4	EA		R	PS		



Parts List for Assembly P/N: 29407  
DRIVE ASSY - Y-AXIS - DPMRX5

29407

Rev A

Printed 6/27/2018

Item	P/N	Title	Detail	Reference(t	Qty	UseAs	Rev	Stat	Type	Mfr	Mfr P/N
91	M6-1.0X25 25B	SCREW-SHCS-STL-BO			4	EA	A	R	PS		
92	M5-0.8X10 10Z	SCREW-PH-PHIL-STL-ZINC			2	EA	-	R	PS		



REVISION TABLE					
REV	REV DESCRIPTION	ECN/NPI#	DATE	DFT	ENG
A	PRODUCTION RELEASE	ECN-14924	09/07/18		LG
B	ADDED ITEMS 17 AND 68. ITEM 57 WAS: 58 71Z	ECN-15007	02/26/19	AC	PB
C	UPDATED BEARING HOUSING ASSEMBLY, BEARING WAS 23940	ECN-16050	11-22-19	AF	TO

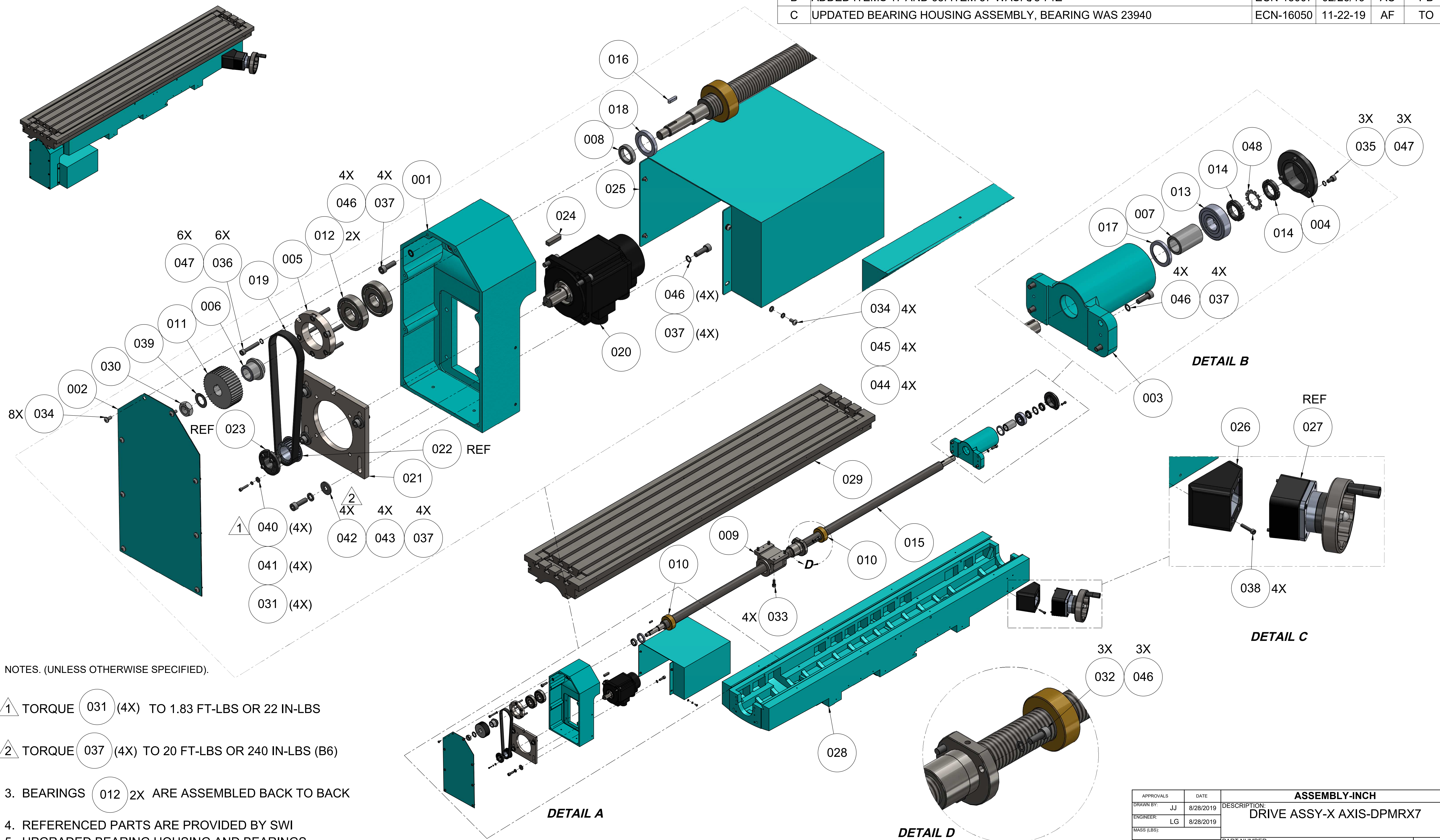

NOTES. (UNLESS OTHERWISE SPECIFIED).

- 1 TORQUE (031) (4X) TO 1.83 FT-LBS OR 22 IN-LBS
- 2 TORQUE (037) (4X) TO 20 FT-LBS OR 240 IN-LBS (B6)
- 3. BEARINGS (012) 2X ARE ASSEMBLED BACK TO BACK
- 4. REFERENCED PARTS ARE PROVIDED BY SWI
- 5. UPGRADED BEARING HOUSING AND BEARINGS INSTALLED ON SERIAL NUMBER: SB410066~SB410070

APPROVALS	DATE	DESCRIPTION: <b>ASSEMBLY-INCH</b>	
DRAWN BY: JJ	8/28/2019	DESCRIPTION: <b>DRIVE ASSY-X AXIS-DPMRX7</b>	
ENGINEER: LG	8/28/2019	PART NUMBER: 29464	
MASS (LBS):		REVISION: <b>C</b>	
THIRD ANGLE PROJECTION		DETAIL: <b>29464</b>	
		SIZE: D	SHEET: 1 OF 3



PART NUMBER: 29464	DRAWN BY: JJ	8/28/2019
	ENGINEER: LG	8/28/2019

Item No.	Part Number	Description	Detail	Type	QTY.	Who	Category	MFG Part Number	Manufacturer
001	HT-012-8D	BRACKET-MOTOR MOUNT-X AXIS-DPM7		Normal	1		Purchased	HT-012-8D	King Rich
002	HT-098-8	COVER		Normal	1		Purchased		
003	HT-011-8B	BRACKET-RIGHT BEARING		Normal	1		Purchased		
004	H-120-6	COVER		Normal	1		Purchased		
005	HT-040-8	HOUSING - BEARING		Normal	1		Purchased		
006	HT-041-6	SLEEVE-LOCKING		Normal	1		Purchased		
007	HT-166-8	BUSHING		Normal	1		Purchased		
008	HX-002	BUSHING		Normal	1		Purchased		
009	HT-022-8	BRACKET-FEED NUT		Normal	1		Purchased		
010	HT-195-14	YOKE STOP-DPM7		Normal	2		Purchased		
011	24545	PULLEY - X AXIS BALLSCREW		Normal	1		Purchased	HT-042-8C	King Rich
012	29463	BEARING - SEALED - ANGULAR CONTACT- 2562LST		Normal	2		Purchased	25 TAC 62BDDG DDG SU C10 PN7B	NSK
013	24512	BEARING-DEEP GROOVE-6305ZZ		Normal	1		Purchased	6305ZZ	Timken
014	24520	NUT - LOCK, M25X 1.5		Normal	2		Purchased		
015	24500	BALLSCREW - X AXIS		Normal	1		Purchased		
016	24546	KEY-5X5X20L		Normal	1		Purchased		
017	HT-167	SEAL-OIL		Normal	1		Purchased		
018	HT-181	SEAL OIL		Normal	1		Purchased		
019	615-5MHP-15	BELT-TIMING 5MM OMEGA HP		Reference	1		Purchased		
020	28164-1	MOTOR-BRUSHLESS-DELTA-1KW		Normal	1		Purchased	ECMA-C21010RS	Delta
021	29423	ADAPTER PLATE-2KW BRUSHLESS MOTOR (100MM)		Normal	1		Purchased	TBD BY (KR)	TBD (KR)
022	29434	PULLEY ASSY-26 TOOTH-15MM WIDE-22MM BORE		Reference	1		Manufactured		
023	29431-2	TAPER LOCK-22 MM BORE		Reference	1		Manufactured		
024	29433-2	KEY-100MM FRAME MOTOR		Normal	1		Purchased		
025	HX-056-14C	MOTOR COVER-X-AXIS-DMP7		Normal	1		Manufactured		
026	21985	SPACER ANGLED 30° Y-AXIS		Normal	1		Manufactured		
027	21946	ELEC HANDWHEEL ASSY - X & Y AXIS		Reference	1		Manufactured		
028	H-034-14C	SADDLE-DPM7		Normal	1		Purchased		
029	HT-029-14C	TABLE-DPM7		Normal	1		Purchased		
030	58-18 51Z	NUT-HEX JAM-STL-ZINC		Normal	1		Purchased		

PART NUMBER: 29464	DRAWN BY: JJ	8/28/2019
	ENGINEER: LG	8/28/2019

Item No.	Part Number	Description	Detail	Type	QTY.	Who	Category	MFG Part Number	Manufacturer
031	6-32X58 (25B)	SCREW-SHCS-STL-BO	STOCKED	Reference	4		Purchased		
032	M8-1.25X20 (25B)	SCREW-SHCS-STL-BO	STOCKED	Normal	3		Purchased		
033	M10-1.5X25 (25B)	SCREW-SHCS-STL-BO	STOCKED	Normal	4		Purchased		
034	M5-0.8X10 10B	SCREW-PH-PHIL-STL-ZINC		Normal	12		Purchased		
035	M6-1.0X10 (25B)	SCREW-SHCS-STL-BO	STOCKED	Normal	3		Purchased		
036	M6-1.0X35 (25B)	SCREW-SHCS-STL-BO	STOCKED	Normal	6		Purchased		
037	M8-1.25X25 (25B)	SCREW-SHCS-STL-BO	STOCKED	Reference	16		Purchased		
038	M6-1.0X30 (25B)	SCREW-SHCS-STL-BO	STOCKED	Normal	4		Purchased		
039	5/8 73B	WASHER-SPLIT LOCK-STL-BO	STOCKED	Normal	1		Purchased		
040	6 (71B)	WASHER-FLAT SAE-STL-BO		Reference	4		Purchased		
041	6 (73B)	WASHER-SPLIT LOCK-STL-BO	STOCKED	Reference	4		Purchased		
042	M8 (79B)	WASHER-FENDER-8.4X24-STL-BO	STOCKED	Normal	4		Purchased		
043	M8 73B	WASHER-SPLIT LOCK-STL-BO		Normal	4		Purchased		
044	M5 (70B)	WASHER-FLAT USS-STL-BO	STOCKED	Normal	4		Purchased		
045	M5 (73B)	WASHER-SPLIT LOCK-STL-BO		Normal	4		Purchased		
046	24009-1	WASHER-BELLEVILLE SPRING LK-SERRATED	.331 ID X .512 OD X .028 THK-5/16 OR M8	Reference	15		Purchased		
047	24009-3	WASHER-BELLEVILLE SPRING LK-SERRATED	.264 ID X .374 OD X .024 THK-1/4 OR M6	Normal	9		Purchased		
048	M25 75Z	WASHER-EXT TOOTH-STL-ZINC		Normal	1		Purchased		



REVISION TABLE					
REV	REV DESCRIPTION	ECN/NPI#	DATE	DFT	ENG
A	PRODUCTION RELEASE	ECN-14924	09-07-18		LG
B	ADDED ITEM 29. ITEM QTY WAS 3	ECN-15007	02-26-19	AC	PB
C	UPDATED BEARING HOUSING ASSEMBLY, BEARING WAS 23940	ECN-16050	11-22-19	JJ	TO

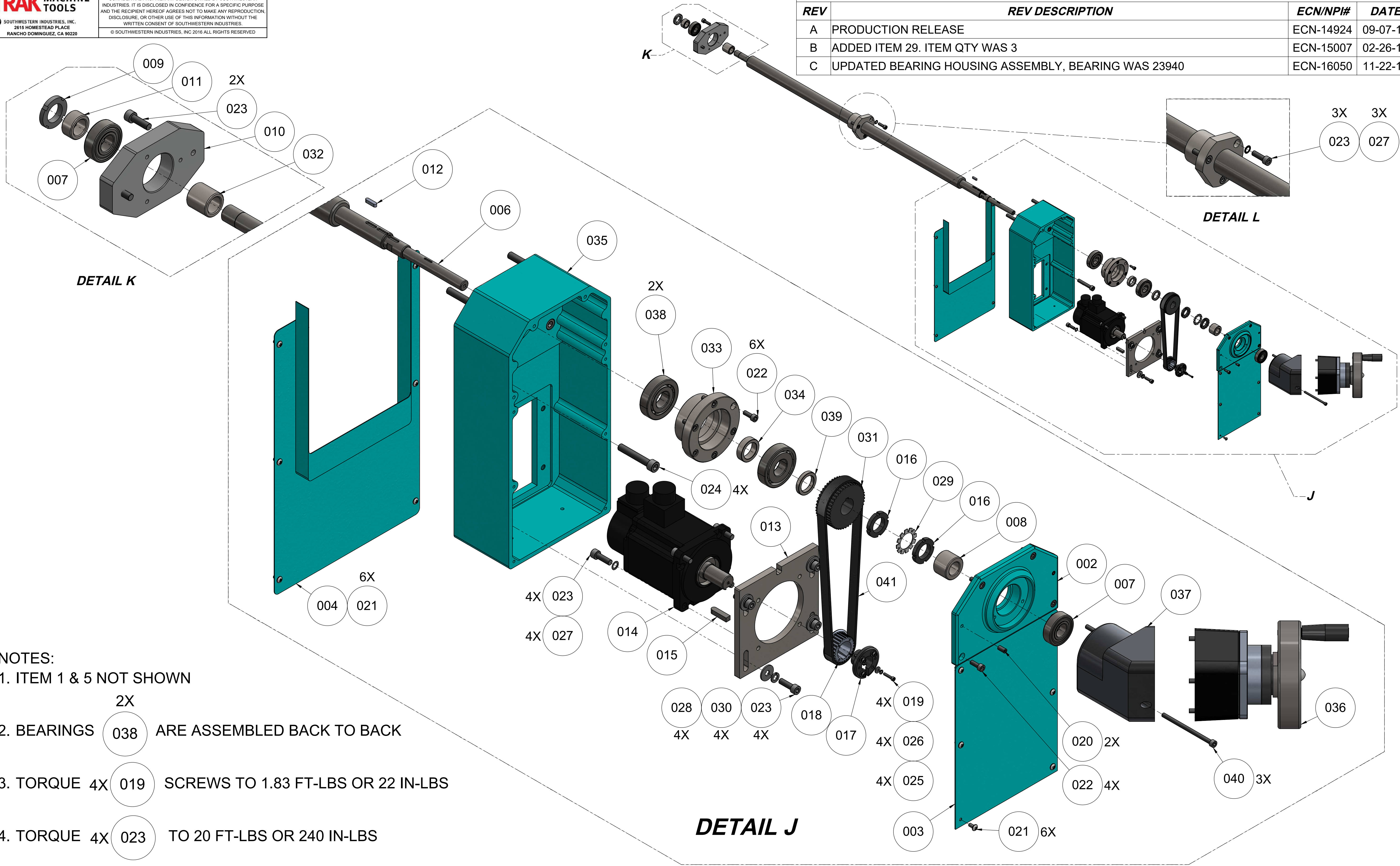

**NOTES:**

- ITEM 1 & 5 NOT SHOWN
- BEARINGS 2X 038 ARE ASSEMBLED BACK TO BACK
- TORQUE 4X 019 SCREWS TO 1.83 FT-LBS OR 22 IN-LBS
- TORQUE 4X 023 TO 20 FT-LBS OR 240 IN-LBS
- REFERNCED PARTS ARE PROVIDED BY SWI
- UPGRADED BEARING HOUSING AND BEARINGS INSTALLED ON SERIAL NUMBER: SB410066~SB410070
- FLATS ADDED TO BALLSCREW ON SERIAL NUMBER: SB410071~SB410075

APPROVALS	DATE	ASSEMBLY-INCH	
DRAWN BY: JJ	8/28/2019	DESCRIPTION: DRIVE ASSY- Y AXIS-DRPMX7	
ENGINEER: LG	8/28/2019	PART NUMBER: 29465	
MASS (LBS):		REV: C	
THIRD ANGLE PROJECTION		SIZE: D	SHEET: 1 OF 2



PART NUMBER:	DRAWN BY: JJ	8/28/2019	
29465	ENGINEER: LG	8/28/2019	

Item No.	Part Number	Description	Detail	Type	QTY.	Who	Category	MFG Part Number	Manufacturer
001	H-034-14C	SADDLE-DPM7		Normal	1		Purchased		
002	HT-028-7A	BRACKET-BEARING-CROSS FEED		Normal	1		Manufactured		
003	HT-096-8A	COVER		Normal	1		Purchased		
004	H-173-8B	COVER		Normal	1		Purchased		
005	H-067-14J	BED-DPM7		Normal	1		Purchased		
006	HT-027-8D	BALLSCREW - Y-AXIS		Normal	1		Purchased		
007	26198-1	BEARING-DEEP GROOVE-6204ZZ		Normal	2		Purchased		
008	HT-041-7	BUSHING-DPM7		Normal	1		Purchased		
009	24519	NUT - LOCK		Normal	1		Purchased		
010	HY-073-8	BRACKET-BEARING BALL SCREW		Normal	1		Purchased		
011	HT-041-8A	BUSHING		Normal	1		Purchased		
012	24546	KEY-5X5X20L		Normal	1		Purchased		
013	29423	ADAPTER PLATE-2KW BRUSHLESS MOTOR (100MM)		Normal	1		Purchased	TBD BY (KR)	TBD (KR)
014	28164-1	MOTOR-BRUSHLESS-DELTA-1KW		Normal	1		Purchased	ECMA-C21010RS	Delta
015	29433-2	KEY-100MM FRAME MOTOR		Normal	1		Purchased		
016	24520	NUT - LOCK, M25X 1.5		Normal	2		Purchased		
017	29431-2	TAPER LOCK-22 MM BORE		Reference	1		Manufactured		
018	29434	PULLEY ASSY-26 TOOTH-15MM WIDE-22MM BORE		Reference	1		Manufactured		
019	6-32X58 (25B)	SCREW-SHCS-STL-BO	STOCKED	Reference	4		Purchased		
020	1/4-20X1/2 40B	SCREW-SOC SET-STL-BO-CUP		Normal	2		Purchased		
021	10-24X38 10Z	SCREW-PH-PHIL-STL-BO		Normal	12		Purchased		
022	M6-1.0X16 (25B)	SCREW-SHCS-STL-BO	STOCKED	Normal	10		Purchased		
023	M8-1.25X25 (25B)	SCREW-SHCS-STL-BO	STOCKED	Reference	13		Purchased		
024	M10-1.5X60 (25B)	SCREW-SHCS-STL-BO	STOCKED	Normal	4		Purchased		
025	6 (71B)	WASHER-FLAT SAE-STL-BO		Reference	4		Purchased		
026	6 (73B)	WASHER-SPLIT LOCK-STL-BO	STOCKED	Reference	4		Purchased		
027	24009-1	WASHER-BELLEVILLE SPRING LK-SERRATED	.331 ID X .512 OD X .028 THK-5/16 OR M8	Reference	7		Purchased		
028	M8 (79B)	WASHER-FENDER-8.4X24-STL-BO	STOCKED	Normal	4		Purchased		
029	M25 75Z	WASHER-EXT TOOTH-STL-ZINC		Normal	1		Purchased		
030	M8 73B	WASHER-SPLIT LOCK-STL-BO		Normal	4		Purchased		
031	24544	PULLEY - Y AXIS BALLSCREW		Normal	1		Purchased	HT-042-8A	King Rich
032	HT-041-8B	BUSHING		Normal	1		Purchased	HT-041-8B	King Rich
033	HT-077-8	HOUSING-BEARING		Normal	1		Purchased		
034	MB110090	SPACER		Normal	1		Purchased		
035	HT-028-8D	BRACKET-MOTOR MOUNT-Y AXIS-DPM7		Normal	1		Purchased	HT-028-8D	King Rich
036	21946	ELEC HANDWHEEL ASSY - X & Y AXIS		Reference	1		Manufactured		
037	22904	SPACER ANGLED 45° Y-AXIS KING RICH		Normal	1		Manufactured		
038	29463	BEARING - SEALED - ANGULAR CONTACT- 2562LST		Normal	2		Purchased	25 TAC 62BDDG DDG SU C10 PN7B	NSK
039	HT-081-8	SPACER-BEARING		Normal	1		Purchased		
040	M6-1.0X95 (25B)	SCREW-SHCS-STL-BO		Normal	3		Purchased		
041	670-5MHP-15	BELT-TIMING 5MM OMEGA HP		Reference	1		Purchased		

NOTICE: THIS DESIGN WAS ORIGINATED BY AND EMBODIES A CONFIDENTIAL PROPRIETARY DESIGN OWNED BY SOUTHWESTERN INDUSTRIES. IT IS DISCLOSED IN CONFIDENCE FOR A SPECIFIC PURPOSE AND THE RECIPIENT HEREOF AGREES NOT TO MAKE ANY REPRODUCTION, DISCLOSURE OR OTHER USE OF THIS INFORMATION WITHOUT THE WRITTEN CONSENT OF SOUTHWESTERN INDUSTRIES.

© SOUTHWESTERN INDUSTRIES, INC. 2017 ALL RIGHT RESERVED

REVISIONS					
REV	DESCRIPTION	ECN	DATE	DFT	ENG
A	PRODUCTION RELEASE	14924	09/07/18	AC	LG
B	ITEM 6 WAS: 24519	15007	02/26/19	AC	PB
C	ADDED NOTES: 4,5,6	16195	06/12/20	AF	TO

D  
C  
B  
A

D  
C  
B  
A

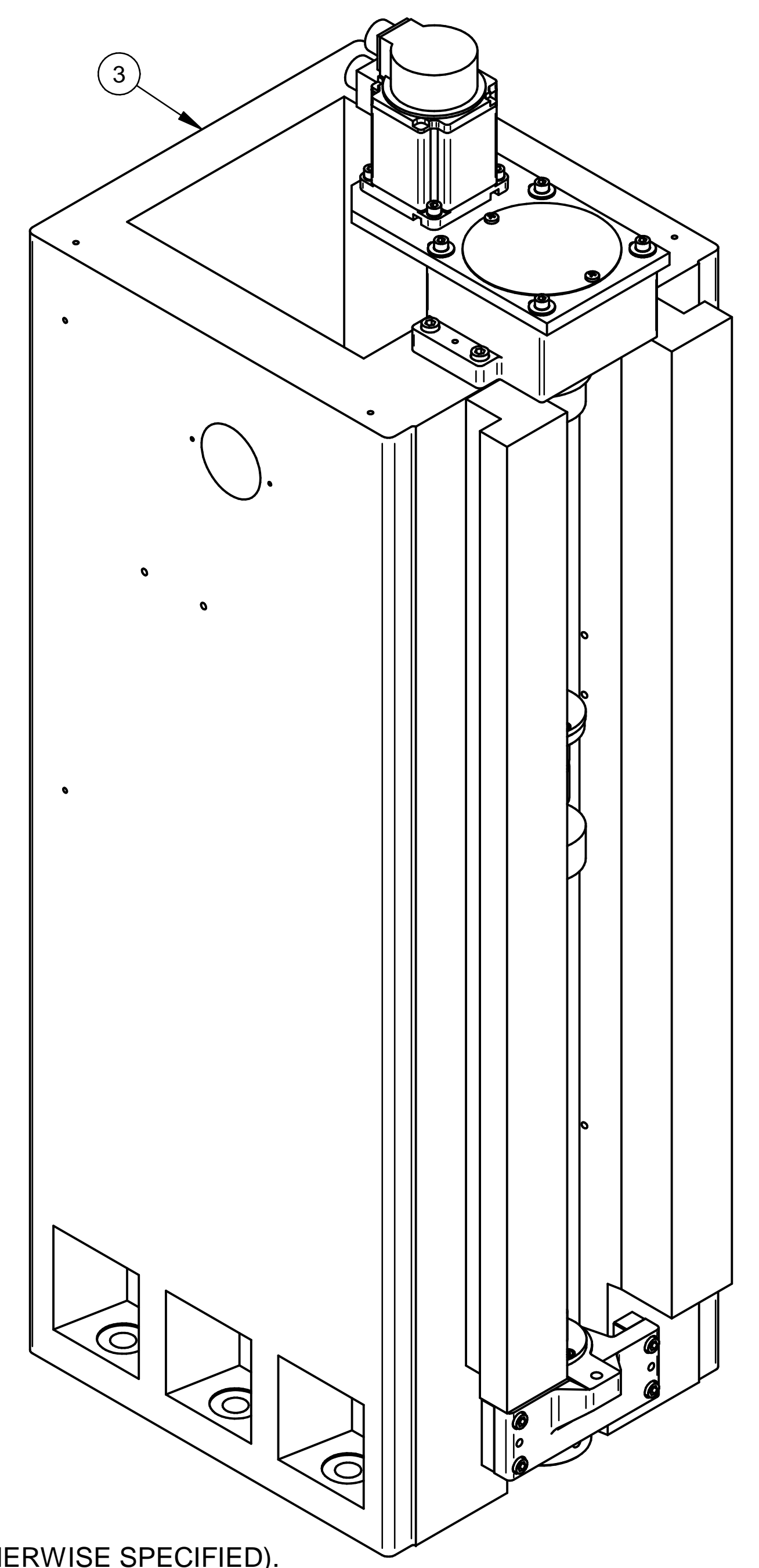
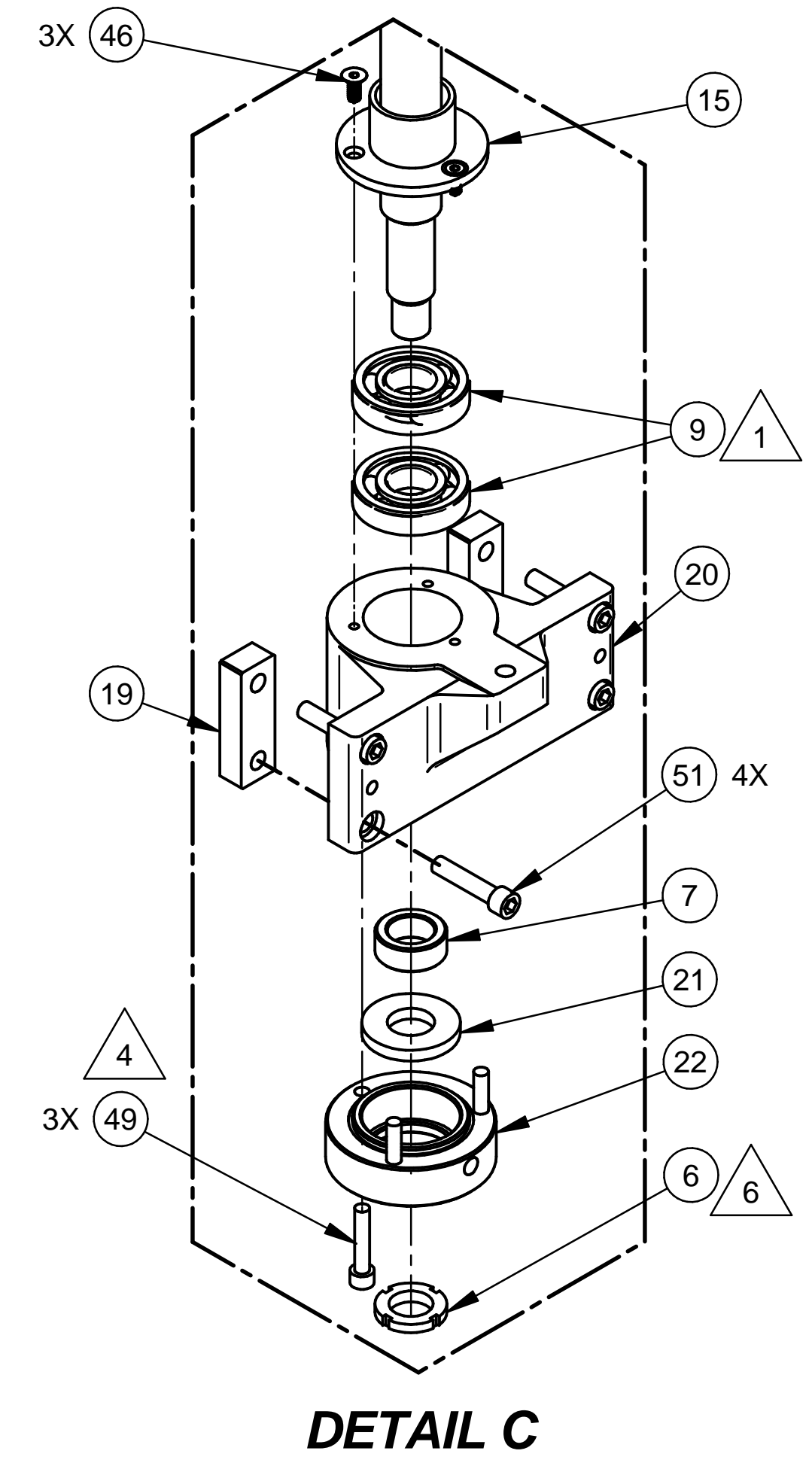
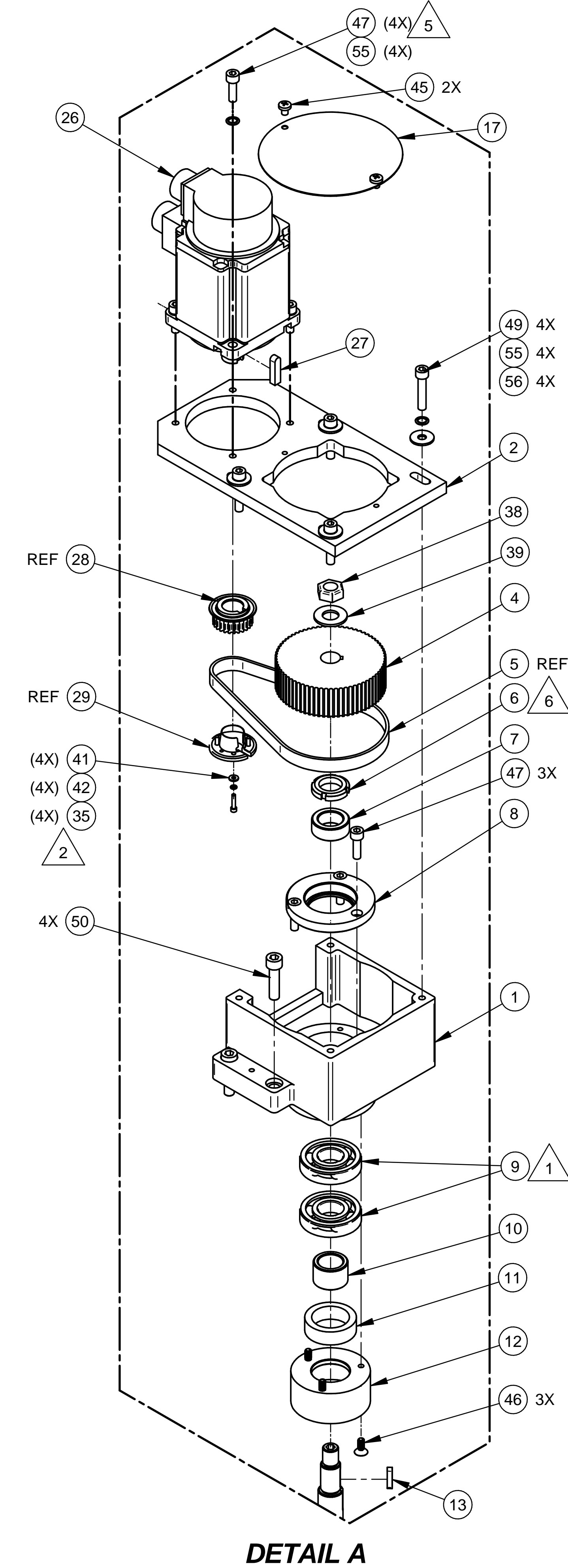
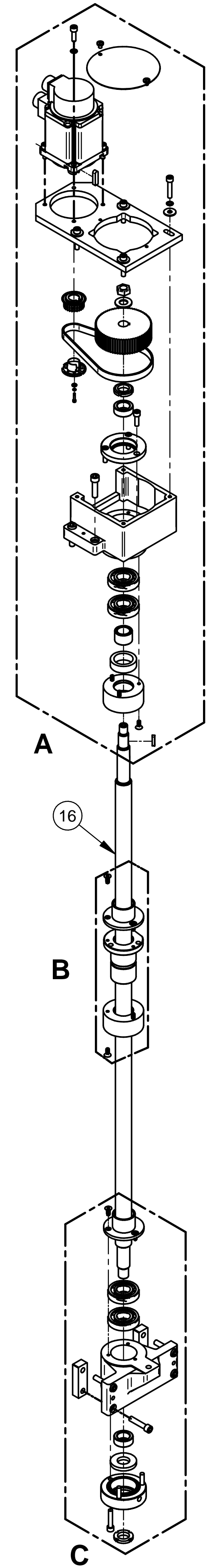
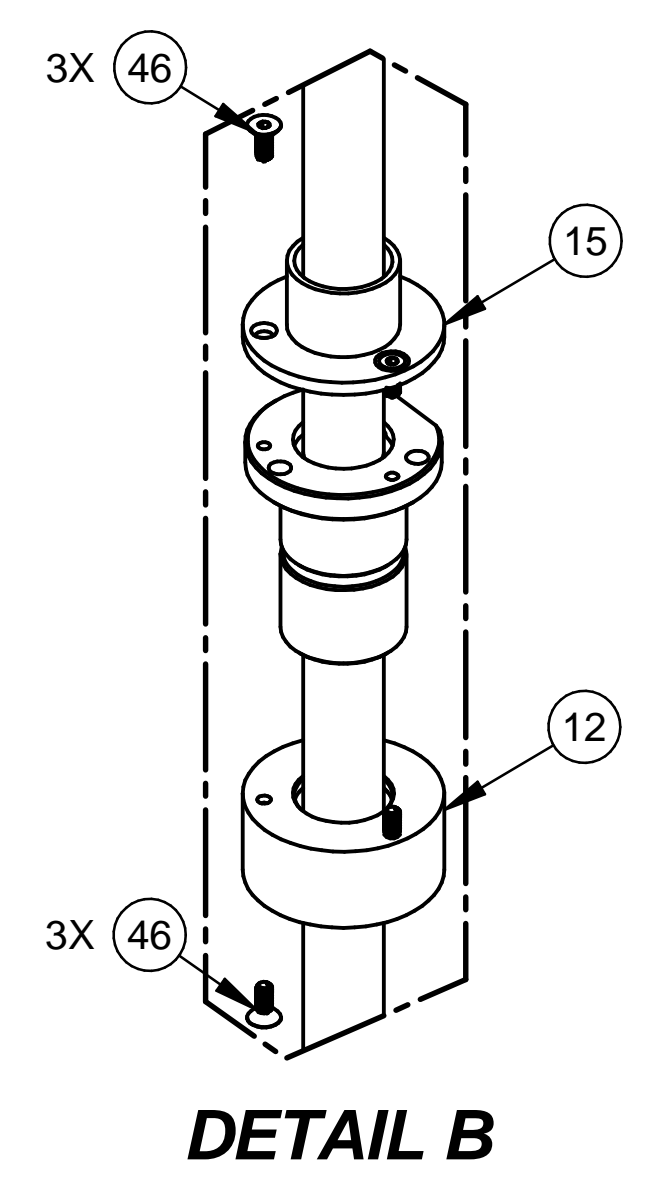

- NOTES: (UNLESS OTHERWISE SPECIFIED).
- 1. BEARINGS (ITEM 9) ARE ASSEMBLED FACE TO FACE
  - 2. TORQUE 6-32X5/8 SCREWS (ITEM 35) TO 1.83 FT-LBS OR 22 IN-LBS
  - 3. REFERENCED PARTS ARE PROVIDED BY SWI
  - 4. TORQUE M8-1.25X40 SCREWS (ITEM 49) TO 243 IN-LBS
  - 5. TORQUE M8-1.25X25 SCREWS (ITEM 47) TO 156 IN-LBS
  - 6. TORQUE 24515 NUTLOCK (ITEM 6) TO 113 IN-LBS

DIMENSIONS ARE IN MILLIMETERS  
 1-4 ±0.020,  
 4-16 ±0.025,  
 16-63 ±0.050,  
 63-250 ±0.070,  
 250-1000 ±0.100,  
 1000-1500 ±0.200  
 REMOVE ALL SHARP EDGES  
 MASK ALL TAPPED HOLES  
 DIMENSIONS PER ASME Y14.5

APPROVALS		DATE	TITLE	
DRAWN BY	AC	11/14/17	DRIVE ASSY-Z AXIS-DPMRX7	
ENGINEER	LG	11/14/17	SIZE	CODE IDENT. NO.
CHECKER	LG		D	06238
FINISH			DWG NO.	29466
THIRD ANGLE PROJECTION			SCALE:	REV
				C
				SHEET 1 OF 3

8 7 6 5 4 3 2 1

Part Number: 29466

Description: DRIVE ASSY-Z AXIS-DPMRX7

Detail:

Revision: C

Status: Released

Date Created: 10/16/2017

Drawn By: AC

Engineer: LG

REV	ECN/NPI #	DFT	ENG
C	16195	AF	TO
ADDED NOTES: 4,5,6			

Item	Part No.	Description	Detail	Qty	Type	BomUnit	Use As	Rev	Rec Type	MFG	MFG P/N	Status
1	H-140-10	HOLDER FIXED MOTOR		1	Normal		EA	-	PS	KING RICH	H-140-10	Released
2	H-140-14	HOLDER FIXED- DPMRX7		1	Normal		EA	A	PS			Released
3	H-067-8	BODY-MACHINE		1	Normal		EA	-	PS	KING RICH	H-067-8	Released
4	29881-1	PULLEY-BALLSCREW-70 TOOTH-39MM		1	Normal		EA	A	DWG			Released
5	535-5MHP-15	BELT - TIMING 5MM OMEGA HP		1	Reference		EA	A	PS			Released
6	24515	NUT-LOCK	M25 X 1.5	2	Normal		EA	-	PS	KING RICH		Released
7	HX-002-10	BUSHING-BEARING		2	Normal		EA	-	PS	KING RICH	HX-002-10	Released
8	HX-007-9	COVER-BEARING		1	Normal		EA	-	PS	KING RICH	HX-007-9	Released
9	24513	BEARING-ANGULAR CONTACT-U/SET (2)		2	Normal		EA	A	PS			Released
10	HX-002-14	BUSHING-BEARING		1	Normal		EA	A	PS			Released
11	AOS385216	SEAL-OIL-38x52x16		1	Normal		EA	-	PS	KING RICH	AOS385216	Released
12	HX-028-10	SUPPORT-DUST HELMET		2	Normal		EA	-	PS	KING RICH	HX-028-10	Released
13	24543	KEY - 5 x 5 x 25L		1	Normal		EA	-	PL	KING RICH	AK0505025	Released
15	HX-030-10	SUPPORT-DUST HELMET		2	Normal		EA	-	PS	KING RICH	HX-030-10	Released
16	24502	BALLSCREW - Z AXIS		1	Normal		EA	A	PS	KING RICH	HT-089-8B	Released
17	29560	COVER-Z AXIS-DPM7		1	Normal		EA	A	PS			Released
19	H-160-14	SPACER-BRACKET-Z AXIS		2	Normal		EA	A	PS			Released
20	H-160-10	BRACKET-BEARING		1	Normal		EA	A	PS			Released
21	AOS255211	SEAL-OIL-25x52x11		1	Normal		EA	-	PS	KING RICH	AOS255211	Released
22	HX-007-A	COVER-BEARING		1	Normal		EA	A	PS			Released
26	28164-1	MOTOR-BRUSHLESS-DELTA-1KW	ECMA-C21010RS	1	Normal		EA	B	DWG			Released
27	29433-2	KEY-100MM FRAME MOTOR		1	Normal		EA		PS			Released



28	29434	PULLEY ASSY-26 TOOTH-15MM WIDE-22MM BORE		1	Reference	EA	A	PL	Released
29	29431-2	TAPER LOCK - 22MM BORE		1	Reference	EA	A	PS	Released
35	6-32X5/8 25B	SCREW-SHCS-STL-BO		4	Reference	EA		PS	Released
38	5/8-18 51Z	NUT-HEX JAM-STL-ZINC	NON-STOCKABLE	1	Normal	EA	A	PS	Released
39	5/8 71Z	WASHER-FLAT SAE-STL-ZINC	NON-STOCKBLE	1	Normal	EA	A	PS	Released
41	6 71B	WASHER-FLAT SAE-STL-BO		4	Reference	EA	A	PS	Released
42	6 73B	WASHER-SPLIT LOCK-STL-BO		4	Reference	EA		PS	Released
45	1/4-20X5/16 10Z	SCREW-PH-PHIL-STL-ZINC	NON-STOCKABLE	2	Normal	EA	A	PS	Released
46	1/4-20X3/4 26B	SCREW-FHCS-STL-BO		12	Normal	EA	-	PS	Released
47	M8-1.25X25 25B	SCREW-SHCS-STL-BO		4	Reference	EA		PS	Released
49	M8-1.25X40 25B	SCREW-SHCS-STL-BO		7	Normal	EA		PS	Released
50	M10-1.5X40 25B	SCREW-SHCS-STL-BO		4	Normal	EA		PS	Released
51	M10-1.5X20 25B	SCREW-SHCS-STL-BO		4	Normal	EA		PS	Released
55	24009-1	WASHER-BELLEVILLE SPRING LK- SERRATED	.331 ID x .512 OD x .028 THK-5/16 or M8	4	Reference	EA	D	DWG	Released
56	M8 79B	WASHER-FENDER-8.4X24-STL-BO		4	Normal	EA	A	PS	Released

NOTICE: THIS DESIGN WAS ORIGINATED BY AND EMBODIES A CONFIDENTIAL PROPRIETARY DESIGN OWNED BY SOUTHWESTERN INDUSTRIES. IT IS DISCLOSED IN CONFIDENCE FOR A SPECIFIC PURPOSE AND THE RECIPIENT HEREOF AGREES NOT TO MAKE ANY REPRODUCTION, DISCLOSURE OR OTHER USE OF THIS INFORMATION WITHOUT THE WRITTEN CONSENT OF SOUTHWESTERN INDUSTRIES.

© SOUTHWESTERN INDUSTRIES, INC. 2017 ALL RIGHT RESERVED

REVISIONS

REV	DESCRIPTION	ECN	DATE	DFT	ENG
A	PRODUCTION RELEASE	14877	06/08/18	AC	AW
B	TITLE WAS: COOLANT PUMP 1/8HP-220VAC 3/8-19 BSPT WAS: 3/8-18 BSPT	14942	10/16/18	AC	AW
C	CHANGED VIEW OF COOLANT PUMP WIRING	16062	09/27/19	AF	AW

SPECIFICATIONS	
OUTPUT:	1/8 HP
VOLTS:	220VAC
AMP:	0.52 A
R.P.M:	3450
PHASE:	1
POLE:	2

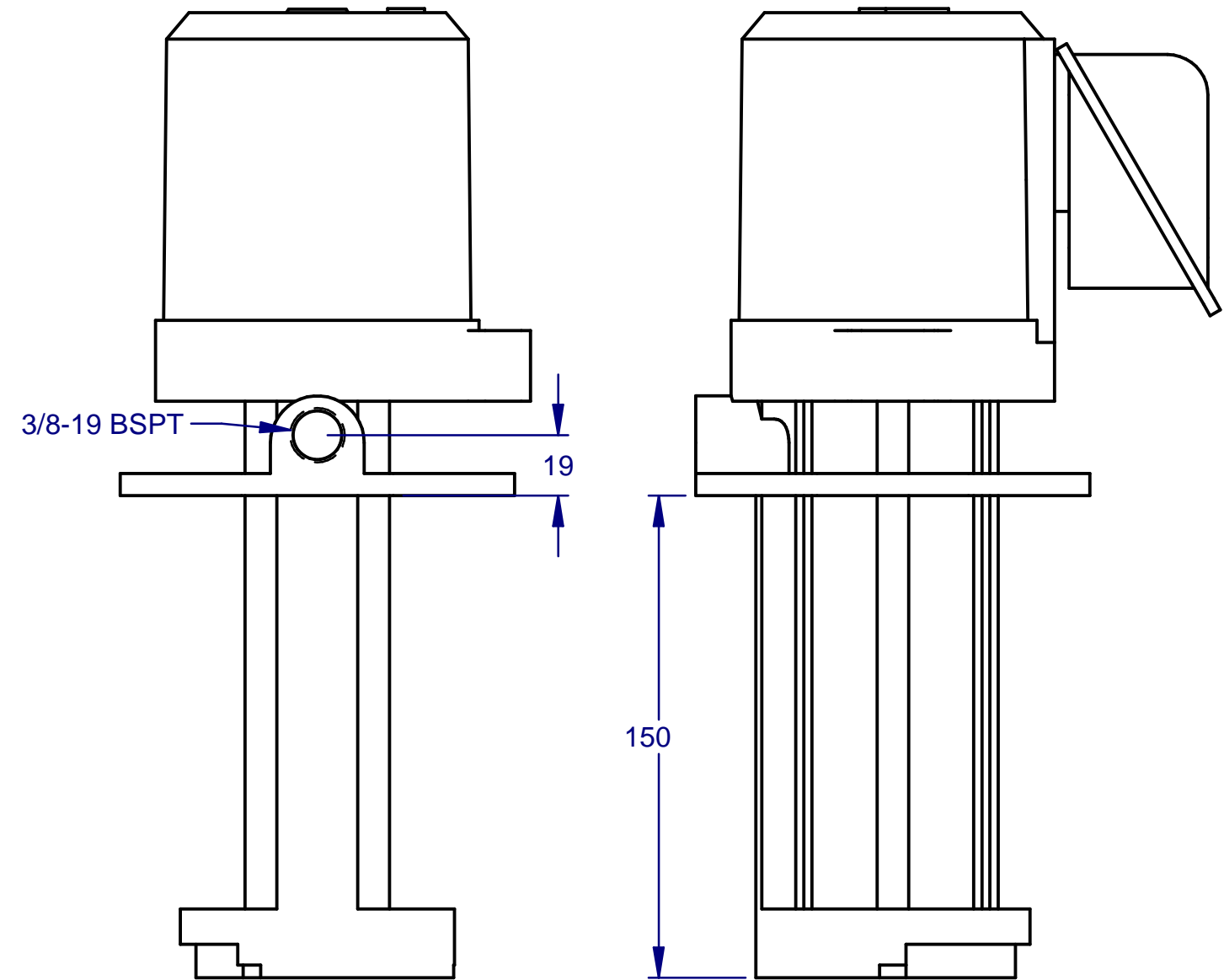
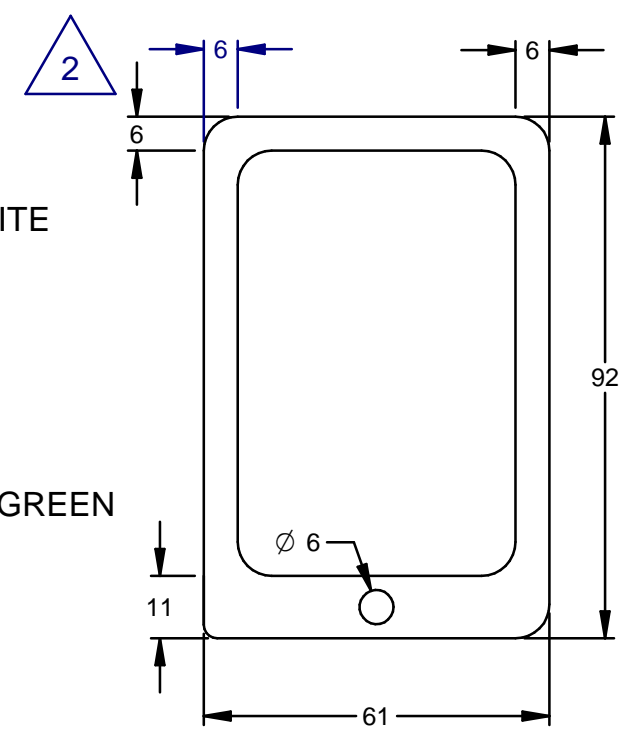
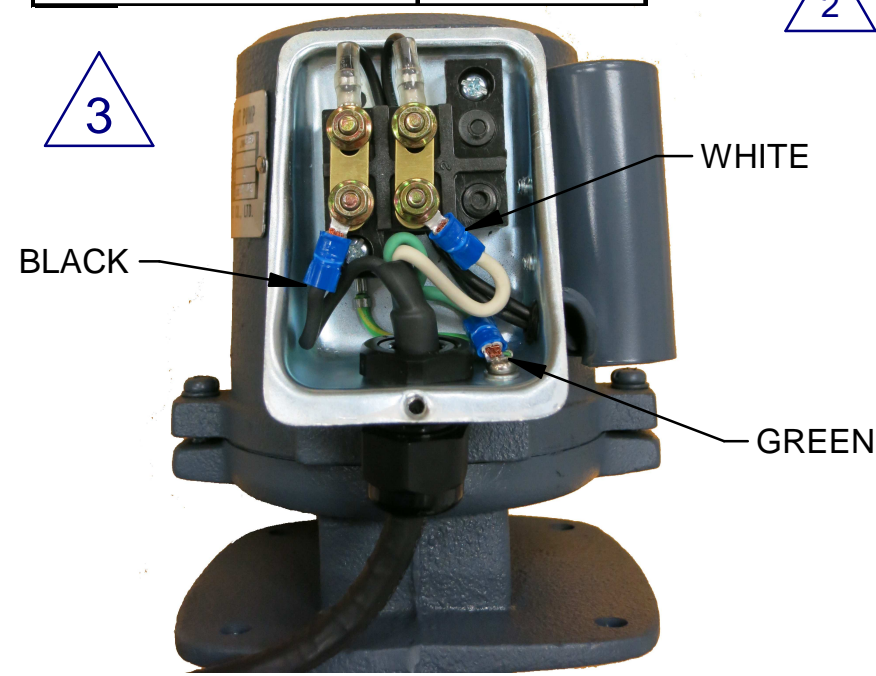

**SPECIFICATION CONTROL DRAWING**  
 IN CASE OF CONFLICT BETWEEN VENDOR SPECIFICATIONS FOR THIS PART AND SPECIFICATIONS OF THIS DRAWING, THE LATTER CONTROLS.  
 IDENTIFICATION OF THE "SUGGESTED SOURCE(S) OF SUPPLY" HEREON IS NOT TO BE CONSTRUED AS A GUARANTEE OF PRESENT OR CONTINUED AVAILABILITY AS A SOURCE OF SUPPLY FOR THE ITEM(S) DESCRIBED ON THE DRAWING.

SWI P/N	VENDOR P/N	VENDOR	MFG P/N	MFG	DESCRIPTION
29063-2		KING RICH	JW-8150,1/8 HPX150MMX220V, SINGLE PHASE	CHIU WEI	COOLANT PUMP 1/8 HP-220AC

NOTES: UNLESS OTHERWISE SPECIFIED

- FOR FUTHER INFORMATION SEE R29063-2\_01 & 02
- 2mm THICK "BUNA-N RUBBER" GASKET INCLUDED AS SHOWN ABOVE
- SEE PAGE 2 FOR REV A AND B CONNECTIONS

DIMENSIONS ARE IN MILLIMETERS 1-4 ±0.020, 4-16 ±0.025, 16-63 ±0.050, 63-250 ±0.070, 250-1000 ±0.100, 1000-1500 ±0.200 REMOVE ALL SHARP EDGES MASK ALL TAPPED HOLES DIMENSIONS PER ASME Y14.5	APPROVALS	DATE				
	DRAWN BY AC	10/19/17				TITLE
	ENGINEER RO	10/19/17	CHECKER	SIZE	CODE IDENT. NO.	REV
	MATERIAL -	FE	THIRD ANGLE PROJECTION	B	06238	29063-2
FINISH -			SCALE: -		SHEET 1 OF 2	

NOTICE: THIS DESIGN WAS ORIGINATED BY AND EMBODIES A CONFIDENTIAL PROPRIETARY DESIGN OWNED BY SOUTHWESTERN INDUSTRIES. IT IS DISCLOSED IN CONFIDENCE FOR A SPECIFIC PURPOSE AND THE RECIPIENT HEREOF AGREES NOT TO MAKE ANY REPRODUCTION, DISCLOSURE OR OTHER USE OF THIS INFORMATION WITHOUT THE WRITTEN CONSENT OF SOUTHWESTERN INDUSTRIES.

© SOUTHWESTERN INDUSTRIES, INC. 2017 ALL RIGHT RESERVED

REVISIONS					
REV	DESCRIPTION	ECN	DATE	DFT	ENG
A	PRODUCTION RELEASE	14877	06/08/18	AC	AW
B	TITLE WAS: COOLANT PUMP 1/8HP-220VAC 3/8-19 BSPT WAS: 3/8-18 BSPT	14942	10/16/18	AC	AW
C	CHANGED VIEW OF COOLANT PUMP WIRING	16062	09/27/19	AF	AW

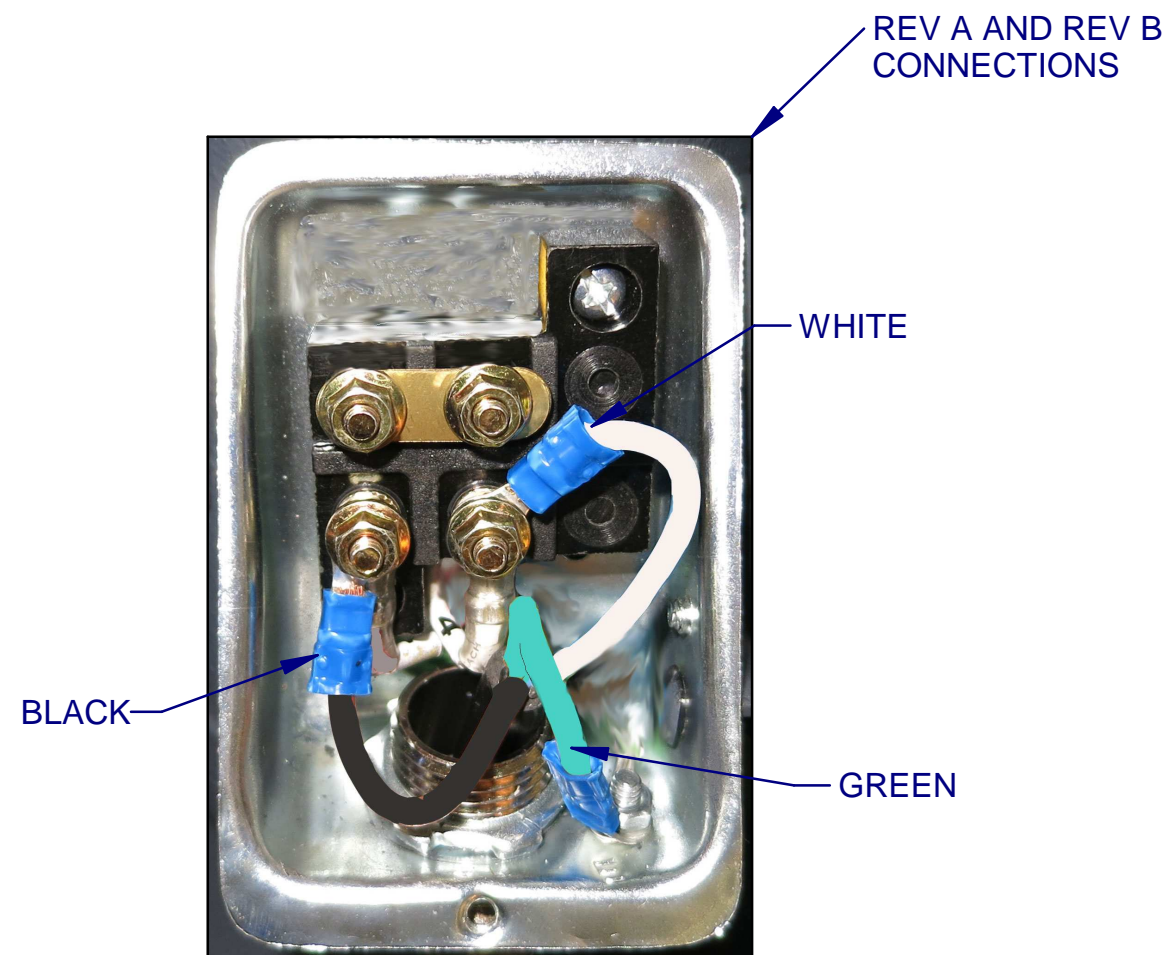

DIMENSIONS ARE IN MILLIMETERS 1-4 ±0.020, 4-16 ±0.025, 16-63 ±0.050, 63-250 ±0.070, 250-1000 ±0.100, 1000-1500 ±0.200 REMOVE ALL SHARP EDGES MASK ALL TAPPED HOLES DIMENSIONS PER ASME Y14.5	APPROVALS	DATE	 <small>SOUTHWESTERN INDUSTRIES, INC.</small>			
	DRAWN BY AC	10/19/17				
	ENGINEER RO	10/19/17	TITLE	COOLANT PUMP 1/8 HP-220VAC-3/8 BSPT		
	CHECKER		SIZE	CODE IDENT. NO.	REV	
MATERIAL	FE	THIRD ANGLE PROJECTION	<b>B</b>	06238	29063-2	<b>C</b>
FINISH			SCALE: -		SHEET 2 OF 2	



NOTICE: THIS DESIGN WAS ORIGINATED BY AND EMBODIES A CONFIDENTIAL PROPRIETARY DESIGN OWNED BY SOUTHWESTERN INDUSTRIES. IT IS DISCLOSED IN CONFIDENCE FOR A SPECIFIC PURPOSE AND THE RECIPIENT HEREOF AGREES NOT TO MAKE ANY REPRODUCTION, DISCLOSURE OR OTHER USE OF THIS INFORMATION WITHOUT THE WRITTEN CONSENT OF SOUTHWESTERN INDUSTRIES.

**FOR GREEN LOWER HEAD HOUSING SEE 20779**

REVISIONS					
REV	DESCRIPTION	ECN	DATE	DRFT	ENG
B	ADDED ITEMS 101-109	13854	6.14.11		LG
C	ADDED ITEMS 98-100, & 110-114. DELETED NOTE 1.	14090	10/08/13		Sal
D	ADDED ITEM 115 NOSE PIECE-R8	14512	04/05/16		LG
E	ITEM 80 WAS: K-B163, ADDED ITEM 116, NOTE 1	14748	11/11/17	AC	LG
F	ITEMS 43-46, 48, 49, 107 WAS: K-B170, K-B175-3, K-B175-2, K-B175-1, K-B175, K-B191, K-B190, 20849.	14863	06/11/18	Sal	LG

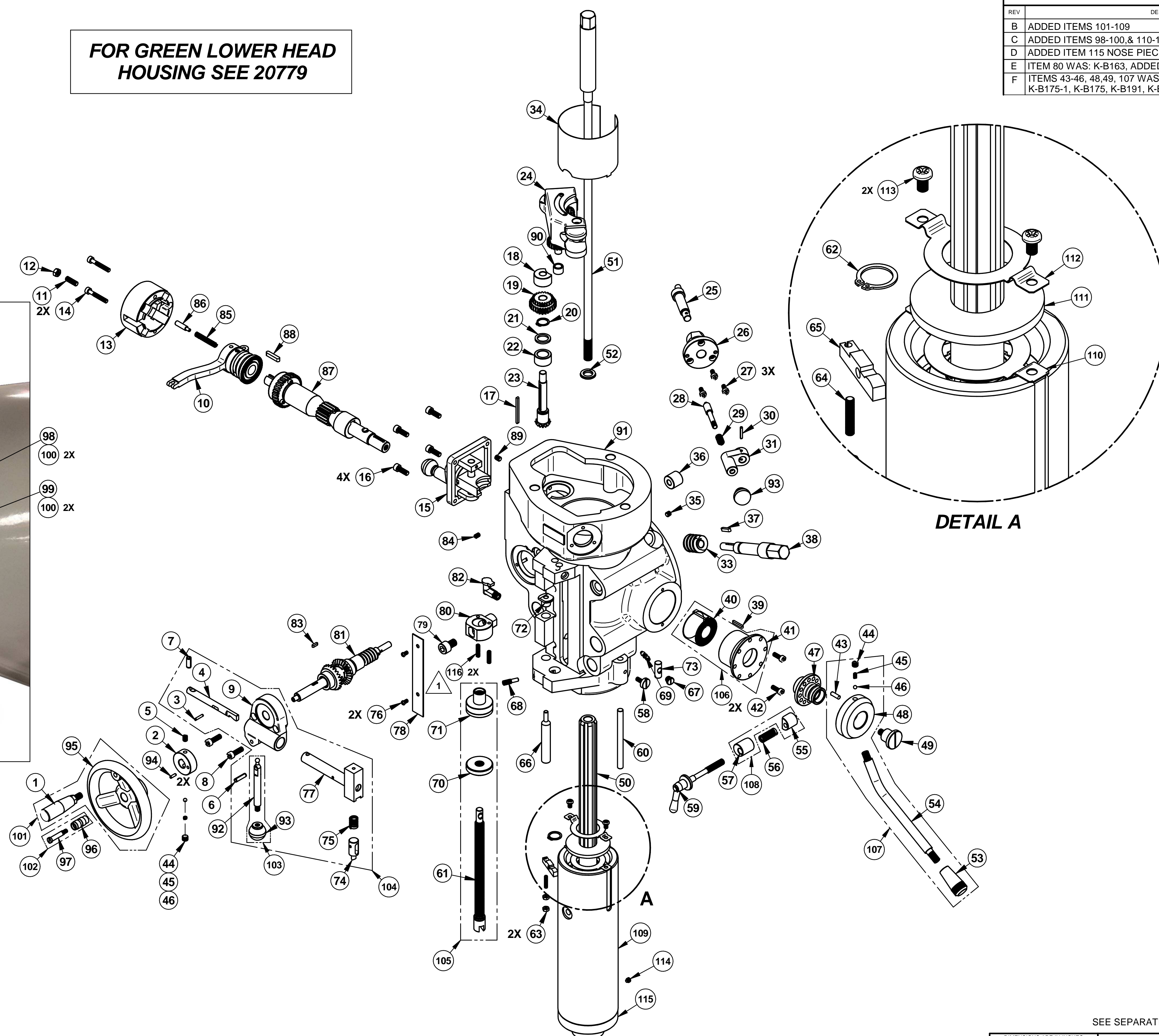
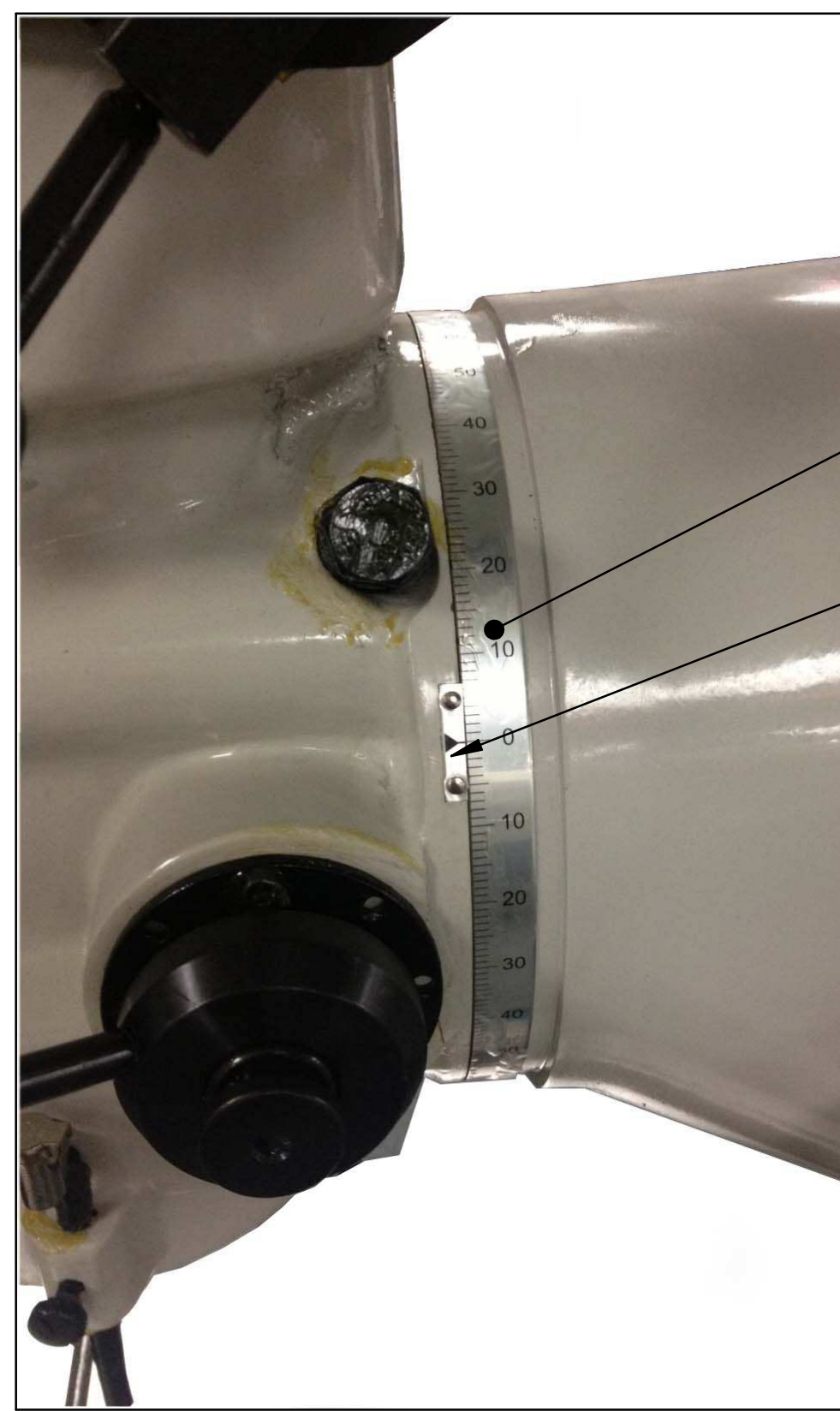

- NOTES: (UNLESS OTHERWISE SPECIFIED).
- ADJUST SET SCREW (ITEM 116) TO TOUCH CASTING, MAKING SURE NO UNDUE STRESS IS PLACED ON QUILL FEED TRIP PLUNGER (ITEM 73). MAKE SURE QUILL FEED TRIP PLUNGER IS TRIPPED PRIOR TO SET SCREWS MAKING CONTACT (B5)
  - ITEMS BOXED ABOVE ARE SOLD AS AN ASSEMBLY.

DIMENSIONS ARE IN INCHES DEC. X = ±.1, XX = ±.01, XXX = ±.005 ANGLES: XX = ±0°30' FRACTIONS = ±1/8 FINISH = 125 RMS REMOVE ALL SHARP EDGES MASK ALL TAPPED HOLES DIMENSIONING PER ASME Y14.5		APPROVALS DRAWN BY RC ENGINEER LG MFE FE	DATE 6-01-07 6.4.07	SOUTHWESTERN INDUSTRIES, INC. 2615 HOMESTEAD PLACE RANCHO DOMINGUEZ, CA. 90220-5610	
TITLE <b>LOWER HEAD HOUSING ASSY-WHITE-R8</b>				SIZE <b>D</b>	REV <b>F</b>
MATERIAL		CODE IDENT. NO. 06238	DWG NO. 24406	SHEET 1 OF 1	
FINISH		SCALE: NONE			

SEE SEPARATE "A" SIZE SHEET FOR PARTS LIST

**Parts List for Assembly P/N: 24581-2**

Printed 5/16/2011

**24581-2**

HEAD ASSY-SPINDLE CONTROL-5 HP-WHITE-40T

REV	ECN	SIGN	DATE
-	13796	PM	5.16.11

Type	PL	Dwg Size	D
Revision	-	Product	
Status	R	Engineer	PM
Date	4/28/2011	Planner Code	
By	RC	Comm Code	

Item	P/N	Title	Detail	Rev	UseAs	Qty	Stat	Reference(t)	Mfr	Mfr P/N
1	24633-2	UPPER HEAD ASSY-SPINDLE CONTROL-5 HP-WHITE-40T		-	EA	1	R			
2	24411	LOWER HEAD HOUSING ASSY-WHITE-40T		A	EA	1	R			

Parts List for Assembly P/N: 24633-2

Printed 6/14/2019

**24633-2**  
 UPPER HEAD ASSY-SPINDLE CONTROL-5  
 HP-WHITE-40T

Type	PL	Dwg Size	D
Revision	A	Product	
Status	U	Engineer	PM
Date	4/27/2011	Planner Code	
By	RC	Comm Code	PURCH

REV	ECN	SIG	DATE
-	13796	PM	5.16.11
A	13822	PM	

Item	P/N	Title	Detail	Qty	UseAs	Rev	Stat	Mfr
1	20697-1	GEAR HOUSING ASSY		1	EA	-	R	TOPONE
2	20697-2	HI-LOW SHIFT CLUTCH ASSY		1	EA	A	U	TOPONE
3	20697-3	HI-LOW SHIFT ASSY	SEE 24939	1	EA	A	R	TOPONE
4	VS12	FRU-K3-SOCKET CAP SCREW M6-P1.0x15L		2	EA		R	TOPONE
5	20697-4	PULLEY PINION ASSY		1	EA	B	U	TOPONE
6	VS64	FRU-K3-BULL GEAR PINION BEARING CAP		1	EA		R	TOPONE
7	VS93	FRU-K3-SCREW M5-P0.8x15L		3	EA		R	TOPONE
8	VS117	FRU-K3-KEY 5x525L		1	EA		R	
9	FVS62	TIMING BELT PULLEY		1	EA		R	TOPONE
10	VS126	FRU-K3-WASHER Ø 5/8		1	EA		R	
11	VS61	FRU-K3-JAM NUT 5/8-11NC		1	EA		R	TOPONE
12	20697-5	LOWER VARI-DISC DRIVE ASSY		1	EA	B	R	TOPONE
13	FVS63	BELT 8YU-600L		1	EA		R	TOPONE
14	VS14-1	FRU-K3-SCREW M8-P1.25x18L		3	EA		R	
15	24169	KEY-8 mm X 8 mm		1	EA	-	R	
16	23597	BELT-MICRO-V-J PROFILE 10 RIBS "J"	340J (864mm)	1	EA	-	R	TOPONE
17	23967	PULLEY-SPINDLE NT 40		1	EA	B	R	TOPONE
18	VS1	FRU-K3-BELT HOUSING		1	EA		R	TOPONE
19	VS137	FRU-K3-SOCKET CAP SCREW M8-P1.25x25L		9	EA		R	
20	FVS13	TOP BEARING CAP		1	EA		R	TOPONE
21	FVS13-1	FRU-K3-WAVE WASHER		1	EA		U	TOPONE
22	FVS15	BALL BEARING (6909VV)		1	EA	A	R	TOPONE
23	VS129	FRU-K3-SCREW- SOC HD CAP M6-P1.0x18L		3	EA		R	

Item	P/N	Title	Detail	Qty	UseAs	Rev	Stat	Mfr
24	VS16	FRU-K3-SPEED CHANGE HOUSING	GREEN	1	EA		R	TOPONE
25	VS07	FRU-K3-SCREW- SOC HD CAP M6-P1.0x35L		4	EA		R	
26	24163	MOTOR ASSY-SPINDLE-5 HP-DPMS3/S5		1	EA	A	R	JIN SHIN ELECTRICAL & MACH. CO. LTD
27	3/8 70P	WASHER-FLAT USS-STL-BO		4	EA		R	
28	3/8-16X1 1/4 24B	SCREW-HEX HEAD-STL-BO		4	EA	-	R	
29	VS11	FRU-K3-MOTOR PULLEY COVER		1	EA		R	TOPONE
30	VS104	FRU-K3-COPPER CHIP(2REQ.)		2	EA		R	TOPONE
31	VS131	FRU-K3-SCREW- FLAT HD PHILIP M5-P0.8x10L		2	EA		R	
32	VS132	FRU-K3-STUD Ø 7/16-100L		3	EA		R	
34	VS101	FRU-K3-VENTILATOR(2REQ.)		2	EA		R	TOPONE
35	VS136	FRU-K3-SCREW- SOC HD CAP M6-P1.0x10L		12	EA		R	
36	VS54	FRU-K3-HANDLE FIX BLOCK		(1)	EA		R	TOPONE
37	VS55	FRU-K3-SET SCREW		(1)	EA		R	TOPONE
38	VS56	FRU-K3-BRAKE LOCK HANDLE		(1)	EA		R	TOPONE
39	VS57	FRU-K3-BAKELITE BALL HANDLE		(1)	EA		R	TOPONE
40	OIL-1	FRU-K3-OIL CUP		1	EA		R	TOPONE
41	20818	BEARING-SPACER		1	EA	-	R	
42	VS52-1	FRU-K3-NUT		(1)	EA		R	
43	23969-2	BRACKET - GEAR SWITCH-5 HP		1	EA	-	R	
45	23986-2	COLLAR-CLAMP Ø76 OD x Ø50 ID x 18 THK		1	EA	-	R	TOPONE
46	M5-0.8X12 25B	SCREW-SHCS-STL-BO		2	EA	-	R	



NOTICE: THIS DESIGN WAS ORIGINATED BY AND EMBODIES A CONFIDENTIAL PROPRIETARY DESIGN OWNED BY SOUTHWESTERN INDUSTRIES. IT IS DISCLOSED IN CONFIDENCE FOR A SPECIFIC PURPOSE AND THE RECIPIENT HEREOF AGREES NOT TO MAKE ANY REPRODUCTION, DISCLOSURE OR OTHER USE OF THIS INFORMATION WITHOUT THE WRITTEN CONSENT OF SOUTHWESTERN INDUSTRIES.

REVISIONS				
REV	DESCRIPTION	ECN	DATE	APPRV
A	ADDED NOTES 2,3 & 4.	12839	1-18-05	JE
B	UPDATE DWG TO SHOW NEW CLAMP ITEM 16	13416	7.28.08	JG
C	ADD NOTE 5 AND SECTION B-B	13482	2.06.09	JG
D	ADDED ITEM 7 & NOTE 6	14252	12/19/14	PM
E	ADDED ITEM 17 AND 4X ITEM 18	14803	02/12/18	LG

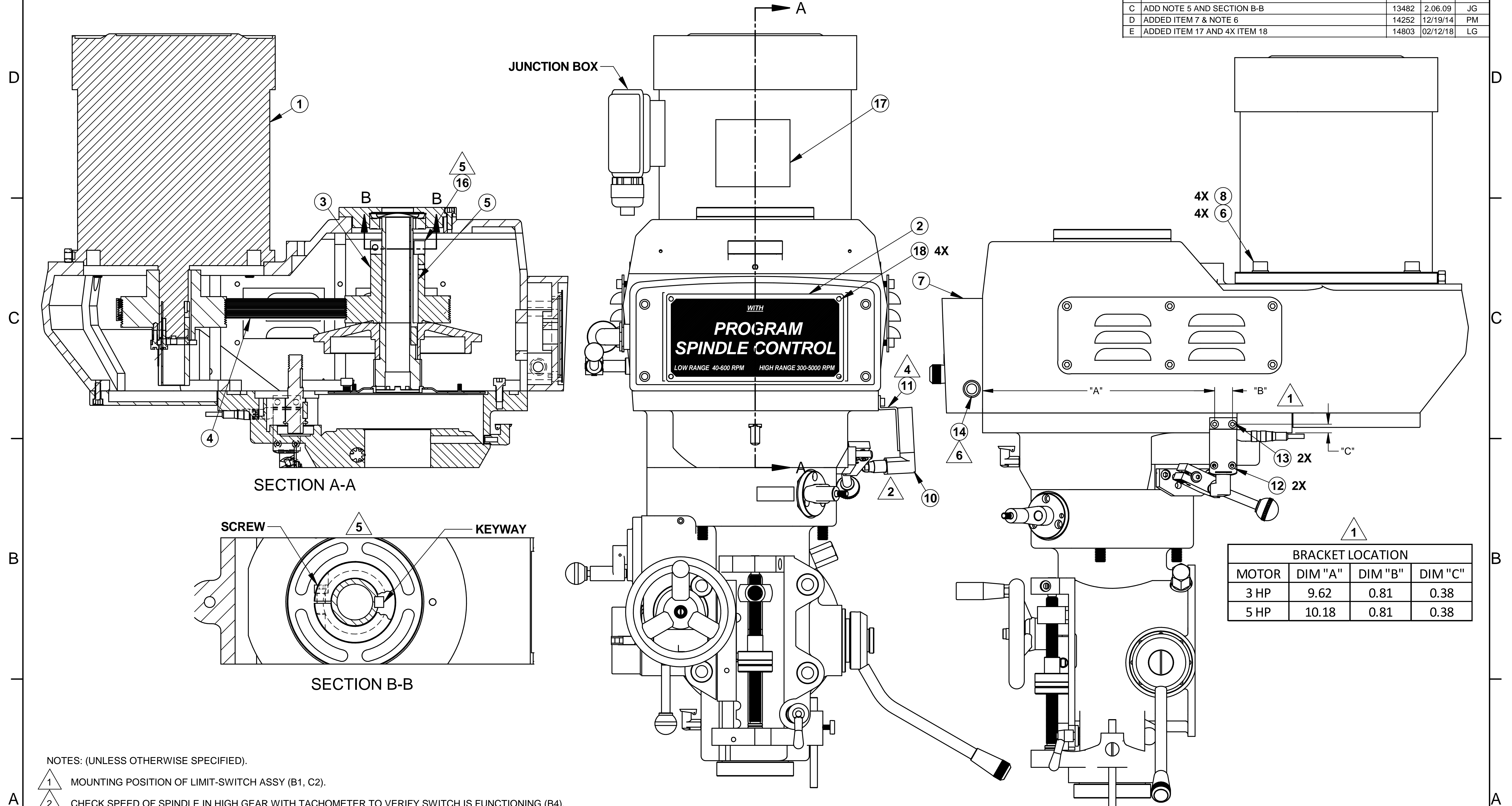

- NOTES: (UNLESS OTHERWISE SPECIFIED).
- 1 MOUNTING POSITION OF LIMIT-SWITCH ASSY (B1, C2).
  - 2 CHECK SPEED OF SPINDLE IN HIGH GEAR WITH TACHOMETER TO VERIFY SWITCH IS FUNCTIONING (B4).
  - 3. RUN SPINDLE IN HIGH GEAR WITH SWITCH SET TO 'FOR' AND VERIFY SPINDLE RUNS CLOCKWISE(FROM TOP). IF IT DOES NOT RUN CORRECTLY, SWAP T1 & T2 AT MOTOR AND RELABEL CORRECTLY SO T1 - U1 AND T2 - V1.
  - 4 BEND BRACKET (ITEM 11) TO ENSURE SWITCH IS TRIPPED (C4).
  - 5 WHEN TIGHTENING CLAMP (ITEM 16), MAKE SURE SIDE WITH SCREW IS 180° FROM SHAFT KEYWAY SEE SECTION B-B (B6, D6).
  - 6 ADD PLUG (ITEM 14) WHEN REQUIRED (B3).

BRACKET LOCATION			
MOTOR	DIM "A"	DIM "B"	DIM "C"
3 HP	9.62	0.81	0.38
5 HP	10.18	0.81	0.38

FOR PARTS LIST SEE SEPARATE "A" SIZE SHEET

DIMENSIONS ARE IN INCHES DEC. X = ±.1, XX = ±.01, XXX = ±.005 ANGLES: XX = ±0°01' FRACTIONS = 1/8 FINISH = 125 RMS REMOVE ALL SHARP EDGES MASK ALL TAPPED HOLES DIMENSIONING PER ASME Y14.5		APPROVALS	DATE	SOUTHWESTERN INDUSTRIES, INC. 2615 HOMESTEAD PLACE RANCHO DOMINGUEZ, CA. 90220-5610	
DRAWN BY JJ		6-02-04		TITLE	
ENGINEER JG		10-05-04		HEAD ASSY - SPINDLE CONTROL	
MATERIAL		FE		SIZE	CODE IDENT. NO.
FINISH		THIRD ANGLE PROJECTION		D	06238
		SCALE: 1 : 2		DWG NO.	23964-XX
				REV	E
				SHEET 1 OF 1	



Parts List for Assembly P/N: 24406

Printed 7/30/2018

24406

LOWER HEAD HOUSING ASSY-WHITE-R8  
SEE 24939, 20779, 26109

Type	PL	Dwg Size	D
Revision	F	Product	
Status	R	Engineer	LG
Date	6/1/2007	Planner Code	
By	RC	Comm Code	PURCH

Item	P/N	Title	Detail	Reference(t	Qty	UseAs	Rev	Stat	Type	Mfr	Mfr P/N
1	K-B125-2	FRU-K3-HANDWHEEL HANDLE (AVAILABLE ONLY IN ASSY. 20835)			1	EA		R	PS	TOPONE	
2	K-B113	FRU-K3-HAND WHEEL CLUTCH			1	EA		R	PS	TOPONE	
3	K-B117	FRU-K3-ROLL PIN Ø3x15L		20832	1	EA		R	PS	TOPONE	
4	K-B103	FRU-K3-CAM ROD		20832	1	EA		R	PS	TOPONE	
5	K-B108	FRU-K3-SOCKET SET SCREW M6-P1.0x8L			1	EA		R	PS	TOPONE	
6	K-B119-1	FRU-K3-ROLL PIN Ø3x20L		20832	1	EA		R	PS	TOPONE	
7	K-B103-1	FRU-K3-CAM ROD PIN Ø5 x 16L		20832	1	EA	A	R	PS	TOPONE	
8	K-B107	FRU-K3-CAP SCREW M6-P1.0x25L			2	EA		R	PS	TOPONE	
9	K-B106	FRU-K3-FEED TRIP BRACKET		20832	1	EA		R	PS	TOPONE	
10	20779-4	OVERLOAD CLUTCH TRIP ASSY	SEE 24939, 26109		1	EA	A	R	PL	TOPONE	
11	K-B73	FRU-K3-SOCKET SET SCREW M6-P1.0x20L			1	EA		R	PS	TOPONE	
12	K-B101	FRU-K3-CHEM BLACKED LOCKNUT M6-P1.0		20831	1	EA		R	PS	TOPONE	
13	K-B99	FRU-K3-CLUTCH ARM COVER			1	EA		R	PS	TOPONE	
14	M5-0.8X50 25B	SCREW-SHCS-STL-BO	NON STOCKABLE		2	EA	-	R	PS		
15	20779-2	QUILL FEED SELECTOR ASSY			1	EA	A	R	PL	TOPONE	
16	K-B67	FRU-K3-CAP SCREW M6-P1.0x18L		20828	4	EA		R	PS	TOPONE	
17	K-B29	FRU-K3-CLUSTER GEAR KEY 3x3x45L			1	EA		R	PS	TOPONE	
18	K-B27	FRU-K3-CLUSTER GEAR SHAFT UPPER BEARING			1	EA		R	PS	TOPONE	
19	K-B28	FRU-K3-CLUSTER GEARS ASSEMBLY			1	EA		R	PS	TOPONE	

Parts List for Assembly P/N: 24406  
 LOWER HEAD HOUSING ASSY-WHITE-R8  
 SEE 24939, 20779, 26109

24406

Rev F

Printed 7/30/2018

Item	P/N	Title	Detail	Reference(t)	Qty	UseAs	Rev	Stat	Type	Mfr	Mfr P/N
20	K-B94	FRU-K3-SNAP RING 95 DOWEL PIN Ø 14			1	EA		R	PS	TOPONE	
21	K-B32	FRU-K3-BEVEL GEAR THRUST SPACER			1	EA		R	PS	TOPONE	
22	K-B33	FRU-K3-BEVEL GEAR BEARING			1	EA		R	PS	TOPONE	
23	K-B31	FRU-K3-CLUSTER GEAR SHAFT 6602BB		20823	1	EA		R	PS	TOPONE	
24	20779-1	WORM GEAR CRADLE ASSY			1	EA	-	R	PL	TOPONE	
25	K-B18	FRU-K3-WORM GEAR CRADLE THROW-OUT		21441	1	EA		R	PS	TOPONE	
26	K-B19	FRU-K3-SHIFT SLEEVE			1	EA		R	PS	TOPONE	
27	K-B25	FRU-K3-CAP SCREW(3REQ.) M5-P0.8x12L			3	EA		R	PS	TOPONE	
28	K-B20	FRU-K3-GEAR SHIFT PLUNGER		20821	1	EA		R	PS	TOPONE	
29	K-B21	FRU-K3-COMPRESSION SPRING		20821	1	EA		R	PS	TOPONE	
30	K-B22	FRU-K3-ROLL PIN Ø3x20L		20821	1	EA		R	PS	TOPONE	
31	K-B23	FRU-K3-SHIFT CRANK		20821	1	EA		R	PS	TOPONE	
33	K-B186	FRU-K3-WORM GEAR			1	EA		R	PS	TOPONE	
34	K-B128	FRU-K3-QUILL SKIRT			1	EA		R	PS	TOPONE	
35	K-B189-1	FRU-K3-ADJ WORM SHAFT SET SCREW M6-P1.0x6L			1	EA		R	PS	TOPONE	
36	K-B42	FRU-K3-BUSHING		20821	1	EA		R	PS	TOPONE	
37	K-B187	FRU-K3-KEY 4x4x18L			1	EA		R	PS	TOPONE	
38	K-B189	FRU-K3-ADJ WORM SHAFT			1	EA		R	PS	TOPONE	
39	K-B171	FRU-K3-KEY 3x3x20L			1	EA		R	PS	TOPONE	
40	K-B178	FRU-K3-CLOCK SPRING(CLOCK SPRING ASSY.)			1	EA		R	PS	TOPONE	
41	K-B177	FRU-K3-SPRING COVER			1	EA		R	PS	TOPONE	
42	K-B169	FRU-K3-RD.HEAD SCREW(2REQ.) M5-P0.8x15L			2	EA		R	PS	TOPONE	
43	FB175-3	DOWEL PIN			1	EA		R	PS	TOPONE	

Item	P/N	Title	Detail	Reference(t)	Qty	UseAs	Rev	Stat	Type	Mfr	Mfr P/N
44	FB116	HANDWHEEL CLUTCH SPRING SCREW M8-P1.25x6L		20849	2	EA		R	PS	TOPONE	
45	FB175-2	COMPRESSION SPRING		20849	2	EA		R	PS		
46	FB114	STEEL BALL		20849	2	EA		R	PS	TOPONE	
47	K-B176	FRU-K3-PINION SHAFT HUB SLEEVE			1	EA		R	PS	TOPONE	
48	FB175	RACK FEED HANDLE HUB		20849	1	EA		R	PS	TOPONE	
49	K-B172	FRU-K3-PINION SHAFT HUB SCREW			1	EA		R	PS	TOPONE	
50	20836	SPINDLE ASSY-K2 & K3	SEE 24939		1	EA	E	R	PL		
51	VS109	DRAWBAR-R8-MANUAL			1	EA	A	R	PS	TOPONE	
52	VS109-1	FRU-K3-SPACER			1	EA		R	PS	TOPONE	
53	FB191	PLASTIC BALL HANDLES		20840	1	EA		R	PS	TOPONE	
54	FB190	PINION SHAFT HUB HANDLE		20840	1	EA		R	PS	TOPONE	
55	K-B148	FRU-K3-QUILL LOCK SLEEVE		20843	1	EA		R	PS	TOPONE	
56	K-B148-1	FRU-K3-COMPRESSION SPRING			1	EA		R	PS	TOPONE	
57	K-B153	FRU-K3-QUILL LOCK SLEEVE TAPPED		20843	1	EA		R	PS	TOPONE	
58	KB-201	FRU-K3-INDICATOR ROD SCREW			1	EA		R	PS	TOPONE	
59	K-B149	FRU-K3-LOCK HANDLE		20845	1	EA		R	PS	TOPONE	
60	KB-202	FRU-K3-INDICATOR ROD			1	EA		R	PS	TOPONE	
61	K-B164	FRU-K3-QUILL STOP MICRO-SCREW		20847	1	EA		R	PS	TOPONE	
62	K-B160	FRU-K3-SNAP RING Ø16			1	EA		R	PS	TOPONE	
63	K-B124-2	FRU-K3-FEED TRIP PLUNGER NUT M40-P0.7			2	EA		R	PS	TOPONE	
64	K-B124-1	FRU-K3-FEED TRIP PLUNGER SOC SET SCREW M4-P0.7x20L			1	EA		R	PS	TOPONE	
65	K-B145	FRU-K3-FEED TRIP LEVER		20842	1	EA		R	PS	TOPONE	
66	K-B124	FRU-K3-FEED TRIP PLUNGER			1	EA		R	PS	TOPONE	

Item	P/N	Title	Detail	Reference(t)	Qty	UseAs	Rev	Stat	Type	Mfr	Mfr P/N
67	K-B185	FRU-K3-REVERSE TRIP BALL LEVER SCREW			1	EA		R	PS	TOPONE	
68	K-B144	FRU-K3-SOCKET SET SCREW		20842	1	EA		R	PS	TOPONE	
69	K-B183	FRU-K3-REVERSE TRIP BALL LEVER			1	EA		R	PS	TOPONE	
70	K-B161	FRU-K3-QUILL MICRO-STOP NUT		20847	1	EA		R	PS	TOPONE	
71	K-B162	FRU-K3-MICROMETER NUT		20847	1	EA		R	PS	TOPONE	
72	K-B123	FRU-K3-TRIP PLUNGER BUSHING			1	EA		R	PS	TOPONE	
73	K-B184	FRU-K3-FEED REVERSE TRIP PLUNGER			1	EA		R	PS	TOPONE	
74	K-B121	FRU-K3-TRIP PLUNGER		20324	1	EA		R	PS	TOPONE	
75	K-B120	FRU-K3-COMPRESSION SPRING		20832	1	EA		R	PS	TOPONE	
76	K-B158	FRU-K3-CHEM BLACKED RD.HD.SCREWS(2 REQ.) M5-P0.8x8L			2	EA		R	PS	TOPONE	
77	K-B118	FRU-K3-CAM ROD SLEEVE ASSY		20832	1	EA		R	PS	TOPONE	
78	K-B159	FRU-K3-MICROMETER SCALE			1	EA		R	PS	TOPONE	
79	KB-200	FRU-K3-SCREW- SOC HD 3/8-24NFx15L			1	EA		R	PS	TOPONE	
80	27350	KNOB-STOP-QUILL-R8			1	EA	A	R	DWG		
81	20779-5	FEED REVERSE CLUTCH ASSY			1	EA	A	R	PL	TOPONE	
82	OIL-1	FRU-K3-OIL CUP			1	EA		R	PS	TOPONE	
83	K-B109	FRU-K3-KEY 3x3x20L			1	EA		R	PS	TOPONE	
84	K-B17-1	FRU-K3-WORM GEAR SET SCREW M6-P1.0x8L			1	EA		R	PS	TOPONE	
85	K-B88-1	FRU-K3-COMPRESSION SPRING			1	EA		R	PS	TOPONE	
86	K-B89	FRU-K3-OVERLOAD CLUTCH LEVER SPRING PLUNGER			1	EA		R	PS	TOPONE	
87	20779-3	QUILL PINION SHAFT ASSY-R8			1	EA	B	R	PL	TOPONE	
88	K-B167	FRU-K3-KEY 5x5x25L			1	EA		R	PS	TOPONE	
89	K-B27-1	FRU-K3-SET SCREW M6-P1.0x8L			1	EA		R	PS	TOPONE	

Item	P/N	Title	Detail	Reference(t)	Qty	UseAs	Rev	Stat	Type	Mfr	Mfr P/N
90	K-B41	FRU-K3-NEEDLE BEARING BA66 BEARING SIZE KO-BA66Z			1	EA		R	PS	TOPONE	
91	K-B192	FRU-K3-QUILL HOUSING			1	EA		R	PS	TOPONE	
92	K-B104	FRU-K3-TRIP HANDLE		20832	1	EA		R	PS	TOPONE	
93	K-B105	FRU-K3-BLACK PLASTIC BALL		20832	1	EA		R	PS	TOPONE	
94	K-B125-1	FRU-K3-HANDWHEEL SPRING PIN Ø3x3x10L			1	EA		R	PS	TOPONE	
95	K-B125	FRU-K3-HANDWHEEL		20835	1	EA		R	PS	TOPONE	
96	K-B111	FRU-K3-REVERSE KNOB		20834	1	EA		R	PS	TOPONE	
97	K-B100	FRU-K3-CAP SET SCREW M5-P0.8x35L		0	1	EA		R	PS	TOPONE	
98	25042	SCALE-HEAD ROTATION-R8			1	EA	-	R	PS	PJ	3105084070
99	25043	POINTER SCALE			1	EA	-	R	PS	PJ	3101084150
100	25044	DRIVE SCREW-SCALE			4	EA	-	R	PS	PJ	50050098
101	20835	FRU-SK2/SK3-HANDWHEEL ASSY			(1)	EA	-	R	PL		
102	20834	FRU-SK2/SK3-FEED REVERSE KNOB ASSY			(1)	EA	-	R	PL		
103	24052	TRIP HANDLE ASSEMBLY (INCLUDES PLASTIC BALL)			(1)	EA	-	R	PL		
104	20832	FRU-SK2/SK3-FEED TRIP ASSY			(1)	EA	-	R	PL		
105	20847	QUILL MICRO NUT & SCREW ASSY			(1)	EA	-	R	PL		
106	24051	CLOCK SPRING ASSEMBLY (SPRING & COVER)			(1)	EA	-	R	PL		
107	20850	FRU-SK4-FEED HANDLE ASSY			(1)	EA	-	R	PL		
108	20843	FRU-SK2/SK3-QUILL LOCK SLEEVE ASSY			(1)	EA	-	R	PL		
109	K-B142	FRU-K3-QUILL			1	EA		R	PS	TOPONE	
110	K-B150-1	STRAIGHT LOWER CLAMP			1	EA		R	PS	TOPONE	
111	K-B151	FELT OIL STRAINER			1	EA		R	PS	TOPONE	
112	K-B150-2	STRAINER UPPER CLAMP			1	EA		R	PS	TOPONE	

Parts List for Assembly P/N: 24406  
 LOWER HEAD HOUSING ASSY-WHITE-R8  
 SEE 24939, 20779, 26109

24406

Rev F

Printed 7/30/2018

Item	P/N	Title	Detail	Reference(t	Qty	UseAs	Rev	Stat	Type	Mfr	Mfr P/N
113	K-B139	SCREW-PH-HD-M5-0.8X10L			2	EA		R	PS	TOPONE	
114	M5-0.8X5 40B	SCREW-SOC SET-STL-BO-CUP			1	EA	-	R	PS		
115	K-B133	NOSE-PIECE-R8			1	EA	A	R	DWG		
116	27351	SCREW-SET-M5-0.8X20-ANTI VIBRATION			2	EA	A	R	DWG		

NOTICE: THIS DESIGN WAS ORIGINATED BY AND EMBODIES A CONFIDENTIAL PROPRIETARY DESIGN OWNED BY SOUTHWESTERN INDUSTRIES. IT IS DISCLOSED IN CONFIDENCE FOR A SPECIFIC PURPOSE AND THE RECIPIENT HEREOF AGREES NOT TO MAKE ANY REPRODUCTION, DISCLOSURE OR OTHER USE OF THIS INFORMATION WITHOUT THE WRITTEN CONSENT OF SOUTHWESTERN INDUSTRIES.

**FOR GREEN-40T  
LOWER HEAD ASSY  
SEE 20698**

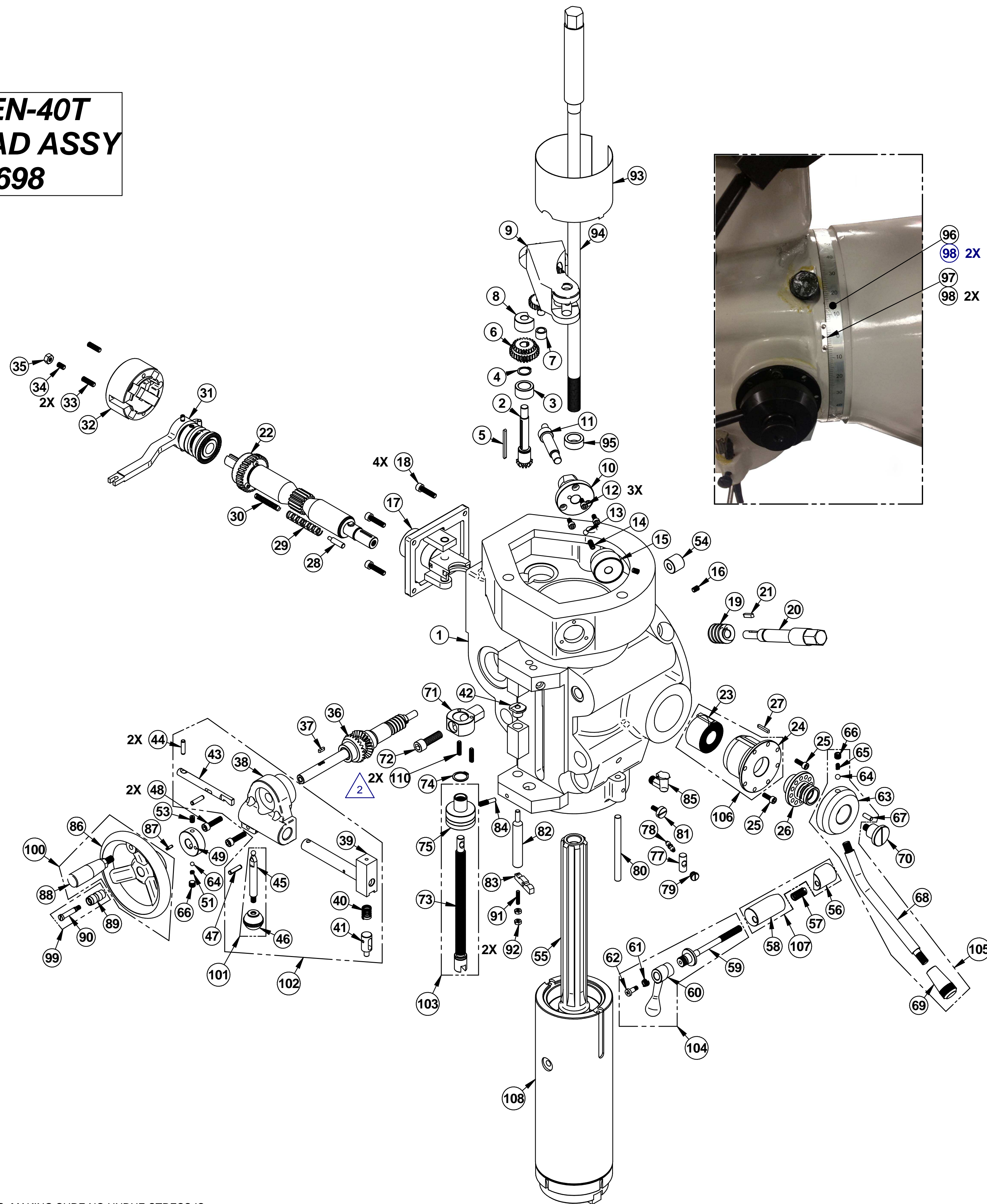

REVISIONS				
REV	DESCRIPTION	ECN	DATE	APPRV
A	ADDED ITEMS 96-98	13616	4.14.10	JG
B	ADDED ITEMS 99-108	13854	6.14.11	LG
C	REVISED ITEMS 12, 38, 44, 65, 70, 75, 90, 94, 103. ADDED ITEMS: 25, 34, 96-98 (PICTORIALLY), & 109, NOTE 1. BOM REFERENCE ITEMS 100-109. DELETED: ITEM 76 & NOTE 2.	14077	01/24/14	LG
D	ITEM 70 (FB172) & 71 (27349) WAS: FB169 & FB163./ ADDED NOTE 2.	14748	11/11/17	LG

NOTES: (UNLESS OTHERWISE SPECIFIED).

1. T BOLT ASSY (ITEM 109) NOT SHOWN.

2. ADJUST SET SCREW (ITEM 110) TO TOUCH CASTING, MAKING SURE NO UNDUE STRESS IS PLACED ON QUILL FEED TRIP PLUNGER (ITEM 77). MAKE SURE QUILL FEED TRIP PLUNGER IS TRIPPED PRIOR TO SET SCREWS MAKING CONTACT (B5)

SEE SEPARATE "A" SIZE SHEET FOR PARTS LIST

DIMENSIONS ARE IN INCHES DEC. X = ±.1, .XX = ±.01, .XXX = ±.005 ANGLES: .XX = ±0°30' FRACTIONS = 1/8 FINISH = 125 RMS REMOVE ALL SHARP EDGES MASK ALL TAPPED HOLES DIMENSIONING PER ASME Y14.5		APPROVALS	DATE	SOUTHWESTERN INDUSTRIES, INC. 2615 HOMESTEAD PLACE RANCHO DOMINGUEZ, CA. 90220-5610	
DRAWN BY	RC	6-01-07		LOWER HEAD HOUSING ASSY- WHITE-40T	
ENGINEER	LG	6.4.07			
MATERIAL	FE	SIZE	CODE IDENT. NO.	DWG NO.	REV
FINISH		D	06238	24411	D
SCALE: 1 : 4			SHEET 1 OF 1		



Parts List for Assembly P/N: 24411

Printed 4/18/2018

24411  
LOWER HEAD HOUSING ASSY-WHITE-40T

Type	PL	Dwg Size	D
Revision	D	Product	
Status	R	Engineer	LG
Date	6/1/2007	Planner Code	
By	RC	Comm Code	PURCH

Item	P/N	Title	Detail	Reference(t)	Qty	UseAs	Rev	Stat	Type
1	FB192	QUILL HOUSING			1	EA		R	PS
2	B31	CLUSTER GEAR SHAFT			1	EA	A	R	PS
3	FB33	BEVEL GEAR BEARING			1	EA		R	PS
4	FB94	SNAP RING 95 DOWEL PIN Ø 14			1	EA		R	PS
5	FB29	CLUSTER GEAR KEY 3x3x45L			1	EA		R	PS
6	FB28	CLUSTER GEARS ASSEMBLY			1	EA		R	PS
7	FB41	NEEDLE BEARING KO-BA66Z			1	EA		R	PS
8	FB27	CLUSTER GEAR SHAFT UPPER BEARING			1	EA		R	PS
9	20698-1	WORM GEAR CRADLE ASSY			1	EA	-	R	PL
10	FB19	SHIFT SLEEVE			1	EA		R	PS
11	FB18	WORM GEAR CRADLE THROW-OUT			1	EA		R	PS
12	FB20	CAP SCREW M5-P0.8x12L			3	EA		R	PS
13	FB24	STEEL BALL			1	EA		R	PS
14	FB25-A	SPRING			2	EA		R	PS
15	FB23	SHIFT CRANK			1	EA		R	PS
16	FB68	SET SCREW M6-P1.0x6L		20829	1	EA	A	R	PS
17	20698-2	QUILL FEED SELECTOR ASSY			1	EA	A	R	PL
18	FB67	CAP SCREW M6-P1.0x18L		20829	4	EA		R	PS
19	FB186	WORM GEAR			1	EA		R	PS
20	FB189	ADJ WORM SHAFT			1	EA		R	PS
21	FB187	KEY 4x4x18L			1	EA		R	PS

Parts List for Assembly P/N: 24411  
 LOWER HEAD HOUSING ASSY-WHITE-40T

24411

Rev D

Printed 4/18/2018

Item	P/N	Title	Detail	Reference(t)	Qty	UseAs	Rev	Stat	Type
22	20698-3	QUILL PINION SHAFT ASSY-40 TAPER	SEE 24939		1	EA	B	R	PL
23	FB178	CLOCK SPRING (CLOCK SPRING ASSY.)			1	EA		R	PS
24	FB177	SPRING COVER			1	EA		R	PS
25	M8-1.25X20 25B	SCREW-SHCS-STL-BO			2	EA	A	R	PS
26	FB176	PINION SHAFT HUB SLEEVE			1	EA		R	PS
27	FB171	KEY 3x3x20L			1	EA		R	PS
28	FB89	OVERLOAD CLUTCH LEVER SPRING PLUNGER			1	EA		R	PS
29	FB88	COMPRESSION SPRING			1	EA		R	PS
30	FB88-1	INTERNAL COMPRESSION SPRING			1	EA		R	PS
31	20698-4	OVERLOAD CLUTCH TRIP ASSY	SEE 24939		1	EA	A	R	PL
32	FB99	CLUTCH ARM COVER			1	EA		R	PS
33	FB73	CAP SCREW M5-P0.8x40L			2	EA		R	PS
34	FB100	SOCKET SET SCREW M6-P1.0x20L			1	EA		R	PS
35	FB101	CHEM BLACKED LOCKNUT M6-P1.0			1	EA		R	PS
36	20698-5	FEED REVERSE CLUTCH ASSY			1	EA	-	R	PL
37	FB109	KEY 3x3x20L			1	EA		R	PS
38	FB106	FEED TRIP BRACKET		20833	1	EA		R	PS
39	FB118	CAM ROD SLEEVE ASSY.		20833	1	EA		R	PS
40	FB120	COMPRESSION SPRING		20833	1	EA		R	PS
41	FB121	TRIP PLUNGER		20833	1	EA		R	PS
42	FB123	TRIP PLUNGER BUSHING			1	EA		R	PS
43	FB103	CAM ROD		20833	1	EA		R	PS
44	FB117	ROLL PIN Ø 3x15L		20833	2	EA		R	PS
45	FB104	TRIP HANDLE		20833	1	EA		R	PS

Parts List for Assembly P/N: 24411  
 LOWER HEAD HOUSING ASSY-WHITE-40T

24411

Rev D

Printed 4/18/2018

Item	P/N	Title	Detail	Reference(t)	Qty	UseAs	Rev	Stat	Type
46	FB105	BLACK PLASTIC BALL		20833	1	EA		R	PS
47	FB119-1	ROLL PIN Ø 3x20L		20833	1	EA		R	PS
48	FB107	CAP SCREW M6-P1.0x25L			2	EA		R	PS
49	FB113	HAND WHEEL CLUTCH			1	EA		R	PS
51	FB115	COMPRESSION SPRING			1	EA		R	PS
53	FB108	SET SCREW M6-P1.0x8L			1	EA		R	PS
54	FB42	BUSHING			1	EA		R	PS
55	20836-1	SPINDLE ASSY-40T	SEE 24939		1	EA	B	R	PL
56	FB148	QUILL LOCK SLEEVE TAPPED		20844	1	EA		R	PS
57	FB148-1A	COMPRESSION SPRING		20844	1	EA		R	PS
58	FB153	QUILL LOCK SLEEVE		20844	1	EA		R	PS
59	FB152	QUILL LOCK BOLT		20846	1	EA		R	PS
60	FB149	LOCK HANDLE		20846	1	EA		R	PS
61	FB149-1	CONICAL COMPRESSIONAL SPRING		20846	1	EA		R	PS
62	FB149-2	SCREW- PHILLIP HD		20846	1	EA		R	PS
63	FB175	RACK FEED HANDLE HUB		20850	1	EA		R	PS
64	FB114	STEEL BALL		0	2	EA		R	PS
65	FB175-2A	COMPRESSION SPRING			1	EA		R	PS
66	FB116	HANDWHEEL CLUTCH SPRING SCREW M8-P1.25x6L		0	2	EA		R	PS
67	FB175-3	DOWEL PIN			1	EA		R	PS
68	FB190	PINION SHAFT HUB HANDLE		20850	1	EA		R	PS
69	FB191	PLASTIC BALL HANDLES		20850	1	EA		R	PS
70	FB172	PINION SHAFT HUB SCREW		0	1	EA		R	PS
71	27349	KNOB-STOP-QUILL-40T			1	EA	A	R	DWG

Parts List for Assembly P/N: 24411  
 LOWER HEAD HOUSING ASSY-WHITE-40T

24411

Rev D

Printed 4/18/2018

Item	P/N	Title	Detail	Reference(t)	Qty	UseAs	Rev	Stat	Type
72	FB200	SCREW- SOC HD 3/8-24NF x 1 1/4			1	EA		R	PS
73	FB164	QUILL STOP MICRO-SCREW		208948	1	EA		R	PS
74	FB160	SNAP RING Ø16			1	EA		R	PS
75	28099	QUILL STOP NUT ASSY-QUICK		208948	1	EA	-	R	PL
77	FB184	FEED REVERSE TRIP PLUNGER			1	EA		R	PS
78	FB183	REVERSE TRIP BALL LEVER			1	EA		R	PS
79	FB185	REVERSE TRIP BALL LEVER SCREW			1	EA		R	PS
80	FB202	INDICATOR ROD			1	EA		R	PS
81	FB201	INDICATOR ROD SCREW			1	EA		R	PS
82	FB124	FEED TRIP PLUNGER			1	EA		R	PS
83	FB145	FEED TRIP LEVER			1	EA		R	PS
84	FB144	SOCKET SET SCREW			1	EA		R	PS
85	OIL-1	FRU-K3-OIL CUP			1	EA		R	PS
86	FB125	HANDWHEEL			1	EA		R	PS
87	FB125-1	HANDWHEEL SPRING PIN - Ø 3x3x10L			1	EA		R	PS
88	FB125-2	HANDWHEEL HANDLE			1	EA		R	PS
89	FB111	REVERSE KNOB			1	EA		R	PS
90	FB126	CAP SCREW M6-P1.0x35L		0	1	EA	-	R	PS
91	FB124-1	FEED TRIP PLUNGER SOC SET SCREW M4-P0.7x20L			1	EA		R	PS
92	FB124-2	FEED TRIP PLUNGER NUT M4-P0.7x20L			2	EA		R	PS
93	FB128	QUILL SKIRT			1	EA		R	PS
94	28083	DRAW BAR-MANUAL-CAT40-K4, DPM3 & 5			1	EA	-	R	PS
95	FVS109-1	SPACER			1	EA		R	PS
96	25041	SCALE-HEAD ROTATION-NT40			1	EA	-	R	PS

Parts List for Assembly P/N: 24411  
 LOWER HEAD HOUSING ASSY-WHITE-40T

24411

Rev D

Printed 4/18/2018

Item	P/N	Title	Detail	Reference(t)	Qty	UseAs	Rev	Stat	Type
97	25043	POINTER SCALE			1	EA	-	R	PS
98	25044	DRIVE SCREW-SCALE			4	EA	-	R	PS
99	20834	FRU-SK2/SK3-FEED REVERSE KNOB ASSY			(1)	EA	-	R	PL
100	20835	FRU-SK2/SK3-HANDWHEEL ASSY			(1)	EA	-	R	PL
101	24099	TRIP HANDLE ASS'Y (INCLUDES PLASTIC BALL)			(1)	EA	-	R	PL
102	20833	FRU-K4-FEED TRIP ASSY			(1)	EA	-	R	PL
103	20847-1	QUILL STOP NUT & SCREW ASSY			(1)	EA	-	R	PL
104	20846	FRU-SK2/SK3-QUILL LOCK HANDLE ASSY			(1)	EA	-	R	PL
105	20850	FRU-SK4-FEED HANDLE ASSY			(1)	EA	-	R	PL
106	24095	CLOCK SPRING ASSEMBLY (SPRING & COVER)			(1)	EA	-	R	PL
107	20844	FRU-SK2/SK3-QUILL LOCK SLEVE ASSY			(1)	EA	-	R	PL
108	FB142	QUILL			(1)	EA	-	R	DWG
109	A071	T-BOLT ASSY			(1)	EA		R	PS
110	27351	SCREW-SET-M5-0.8X20-ANTI VIBRATION			2	EA	A	R	DWG

NOTICE: THIS DESIGN WAS ORIGINATED BY AND EMBODIES A CONFIDENTIAL PROPRIETARY DESIGN OWNED BY SOUTHWESTERN INDUSTRIES. IT IS DISCLOSED IN CONFIDENCE FOR A SPECIFIC PURPOSE AND THE RECIPIENT HEREOF AGREES NOT TO MAKE ANY REPRODUCTION, DISCLOSURE OR OTHER USE OF THIS INFORMATION WITHOUT THE WRITTEN CONSENT OF SOUTHWESTERN INDUSTRIES.  
© SOUTHWESTERN INDUSTRIES, INC. 2018 ALL RIGHT RESERVED

REV		DESCRIPTION	ECN	DATE	DFT	ENG
A		PRODUCTION RELEASE	14948	11/14/18	JJ	JJ

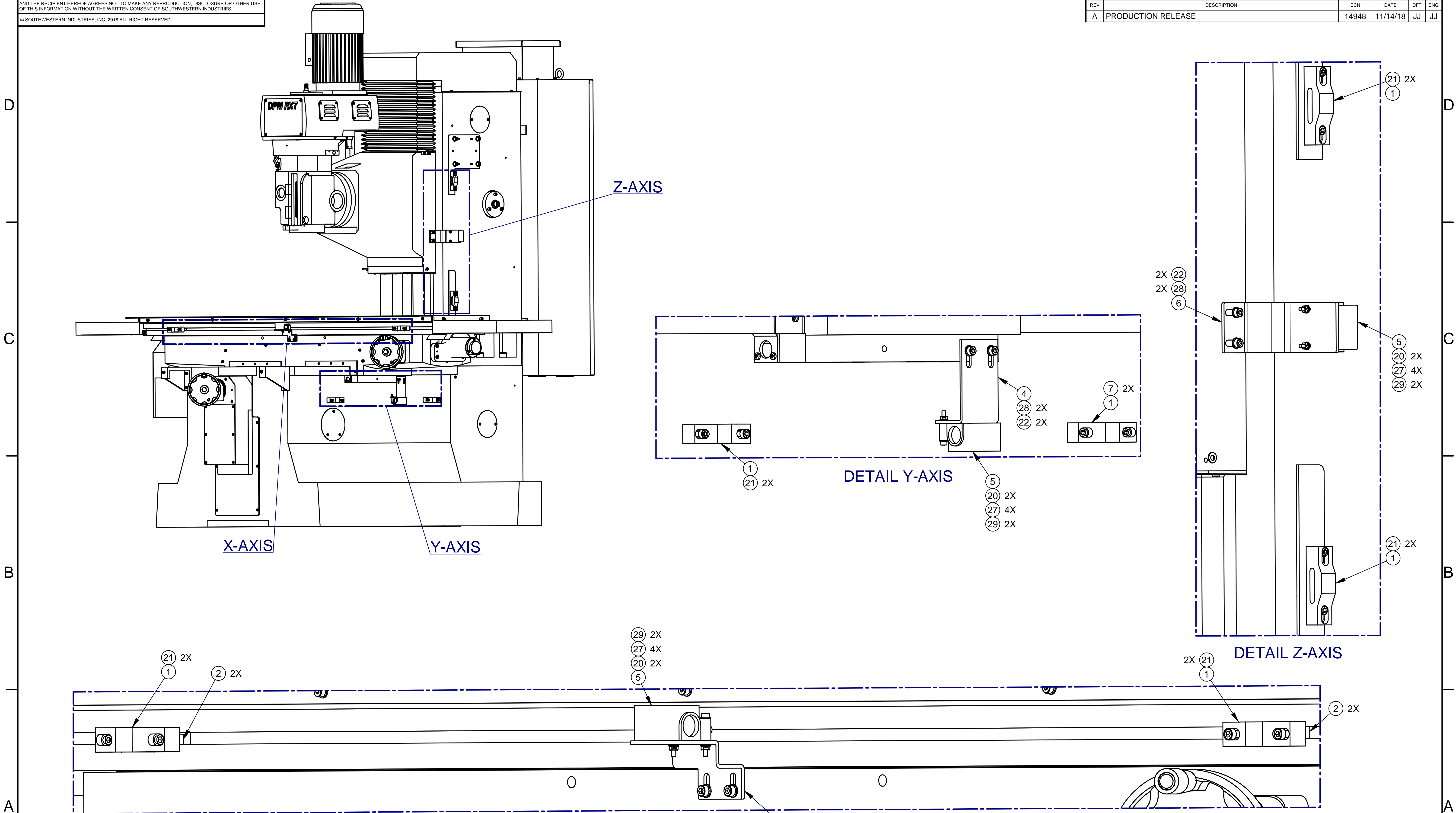

DIMENSIONS ARE IN INCHES  
DEC. .X = ±.1, .XX = ±.01, .XXX = ±.005  
ANGLES .XX = +0°30'  
FRACTIONS = ±1/8  
FINISH = 125 RMS  
REMOVE ALL SHARP EDGES  
MASK ALL TAPPED HOLES  
DIMENSIONING PER ASME Y14.5

APPROVALS		DATE	TRAK MACHINE TOOLS	
DRAWN BY	JJ	07/12/18	<b>LIMIT SWITCH KIT -DPM7</b> CODE IDENT. NO. 06238 DWG NO. 29510-3	
ENGINEER	JJ	07/12/18		
CHECKER	PB	07/12/18		
THIRD ANGLE PROJECTION		SCALE: $\frac{1}{2}$	REV	A
			SHEET 1 OF 2	



NOTICE: THIS DESIGN WAS ORIGINATED BY AND EMBODIES A CONFIDENTIAL PROPRIETARY DESIGN OWNED BY SOUTHWESTERN INDUSTRIES. IT IS DISCLOSED IN CONFIDENCE FOR A SPECIFIC PURPOSE AND THE RECIPIENT HEREOF AGREES NOT TO MAKE ANY REPRODUCTION, DISCLOSURE OR OTHER USE OF THIS INFORMATION WITHOUT THE WRITTEN CONSENT OF SOUTHWESTERN INDUSTRIES.  
© SOUTHWESTERN INDUSTRIES, INC. 2018 ALL RIGHT RESERVED

REVISIONS		ECN	DATE	DFT	ENG
REV	DESCRIPTION				
A	PRODUCTION RELEASE	14948	11/14/18	JJ	JJ

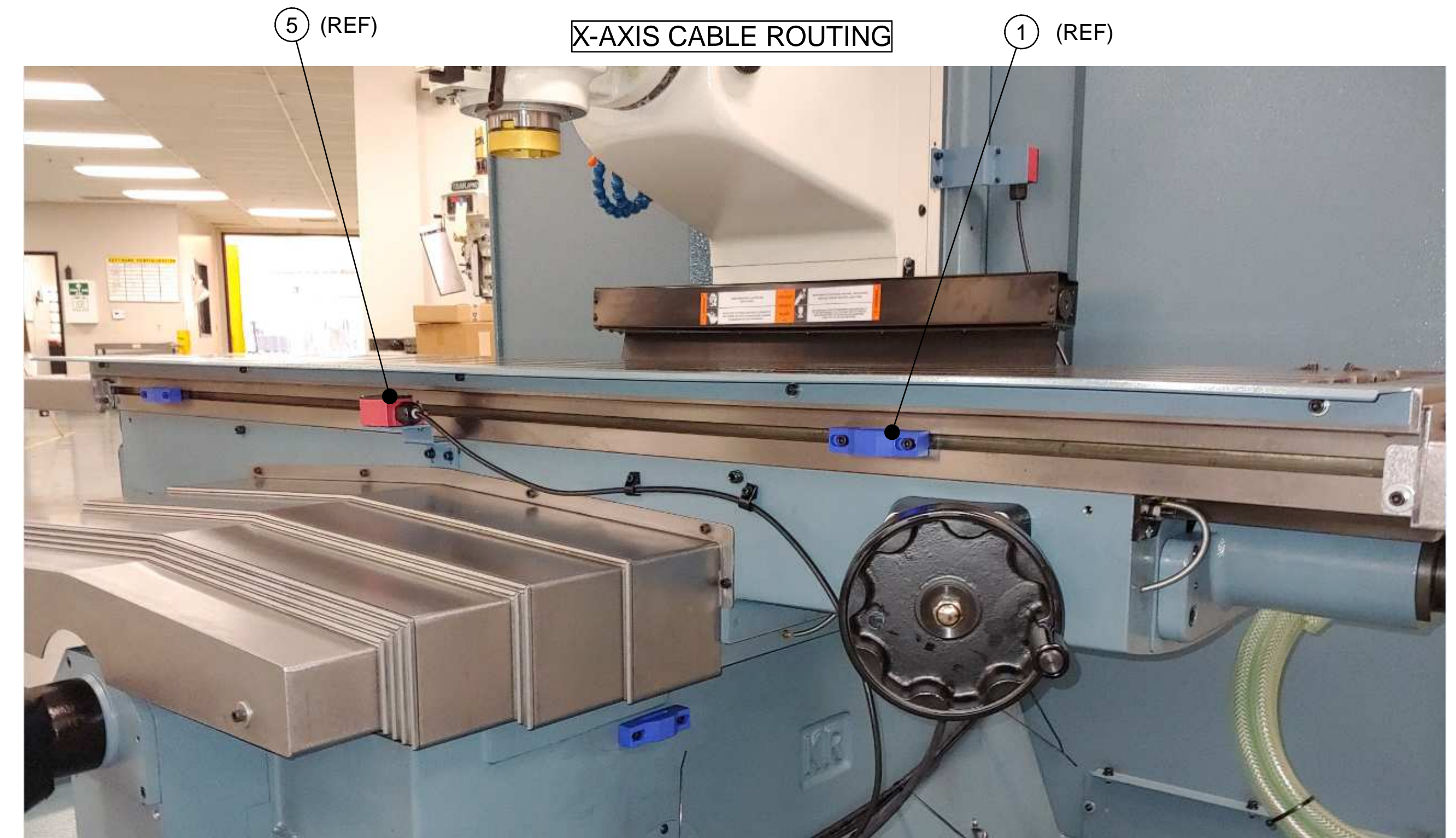
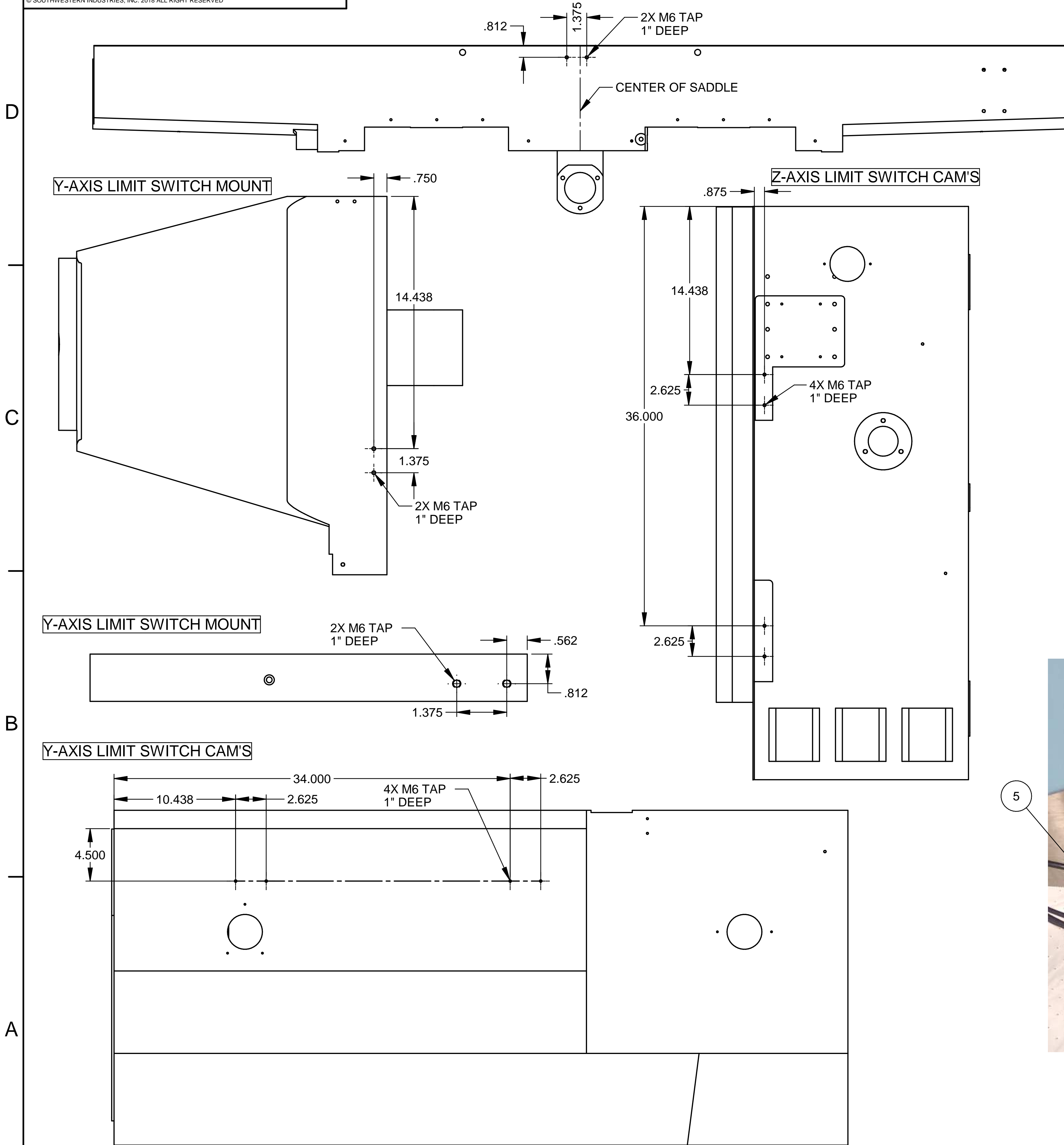

DIMENSIONS ARE IN INCHES  
DEC. .X = ±.1, .XX = ±.01, .XXX = ±.005  
ANGLES .XX = ±0°30'  
FRACTIONS = ±1/8  
FINISH = 125 RMS  
REMOVE ALL SHARP EDGES  
MASK ALL TAPPED HOLES  
DIMENSIONING PER ASME Y14.5

APPROVALS		DATE	TRAK MACHINE TOOLS	
DRAWN BY	JJ	07/12/18	<b>LIMIT SWITCH KIT -DPM7</b> SIZE: <b>D</b> CODE IDENT. NO.: 06238 DWG NO.: 29510-3 REV: A SCALE: SHEET 2 OF 2	
ENGINEER	JJ	07/12/18		
CHECKER	PB	07/12/18		
FE				
THIRD ANGLE PROJECTION				



Parts List for Assembly P/N: 29510-3

Printed 11/14/2018

**29510-3**  
LIMIT SWITCH KIT -DPM7

Type	PL	Dwg Size
Revision	A	Product
Status	R	Engineer
Date	4/4/2018	Planner Code
By		Comm Code

Item	P/N	Title	Detail	Reference(t)	Qty	UseAs	Rev	Stat	Type
1	29512	CAM-LIMIT SWITCH			6	EA	A	R	DWG
2	22113	NUT-T SLOT-M6-1			4	EA	D	R	DWG
3	29513-2	SHEET METAL- LIMIT SWITCH COVER X-AXIS DPM7			1	EA	A	R	DWG
4	29514-2	SHEET METAL - LIMIT SWITCH Y-AXIS DPM7			1	EA	A	R	DWG
5	22551-14	CABLE ASSY-LIMIT SWITCH			3	EA	A	R	PL
6	29515-1	SHEET METAL - LIMIT SWITCH Z-AXIS DPM7			1	EA	A	R	DWG
20	M4-0.7X35 25B	SCREW-SHCS-STL-BO			6	EA	A	R	PS
21	M6-1.0X25 25B	SCREW-SHCS-STL-BO			12	EA	A	R	PS
22	M6-1.0X20 25B	SCREW-SHCS-STL-BO			6	EA	-	R	PS
27	M4 70B	WASHER-FLAT-STL-BO			12	EA	-	R	PS
28	M6 70B	WASHER-FLAT USS-STL-BO			6	EA	-	R	PS
29	M4-0.7 61Z	NUT-KEP-STL-ZINC			6	EA	-	R	PS
30	29510-3-DOC	LIMIT SWITCH KIT -DPM7			1	EA		R	DOC

NOTICE: THIS DESIGN WAS ORIGINATED BY AND EMBODIES A CONFIDENTIAL PROPRIETARY DESIGN OWNED BY SOUTHWESTERN INDUSTRIES. IT IS DISCLOSED IN CONFIDENCE FOR A SPECIFIC PURPOSE AND THE RECIPIENT HEREOF AGREES NOT TO MAKE ANY REPRODUCTION, DISCLOSURE OR OTHER USE OF THIS INFORMATION WITHOUT THE WRITTEN CONSENT OF SOUTHWESTERN INDUSTRIES.  
 © SOUTHWESTERN INDUSTRIES, INC. 2018 ALL RIGHT RESERVED

REVISIONS					
REV	DESCRIPTION	ECN	DATE	DFT	ENG
B	ADDED ITEM 16; ADDED BLOCK LARGE FONT LETTERS FOR LIMIT SWITCH FIXTURE IDENTIFICATION	16182	08/21/20	AF	JJ
C	29513-6 WAS: 29513-1, 29514-4 WAS: 29514-1	16655	04/29/22	AF	LG

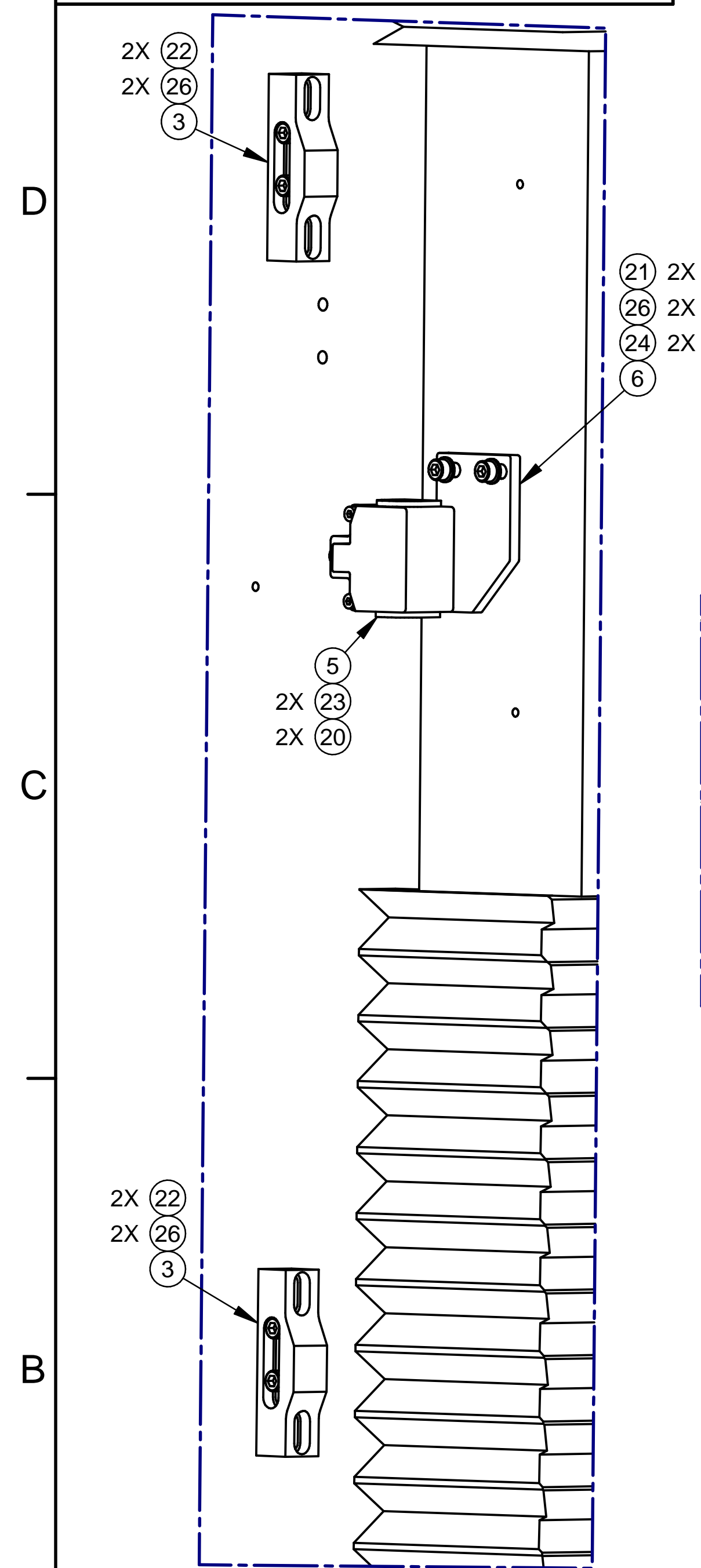

DETAIL Z-AXIS

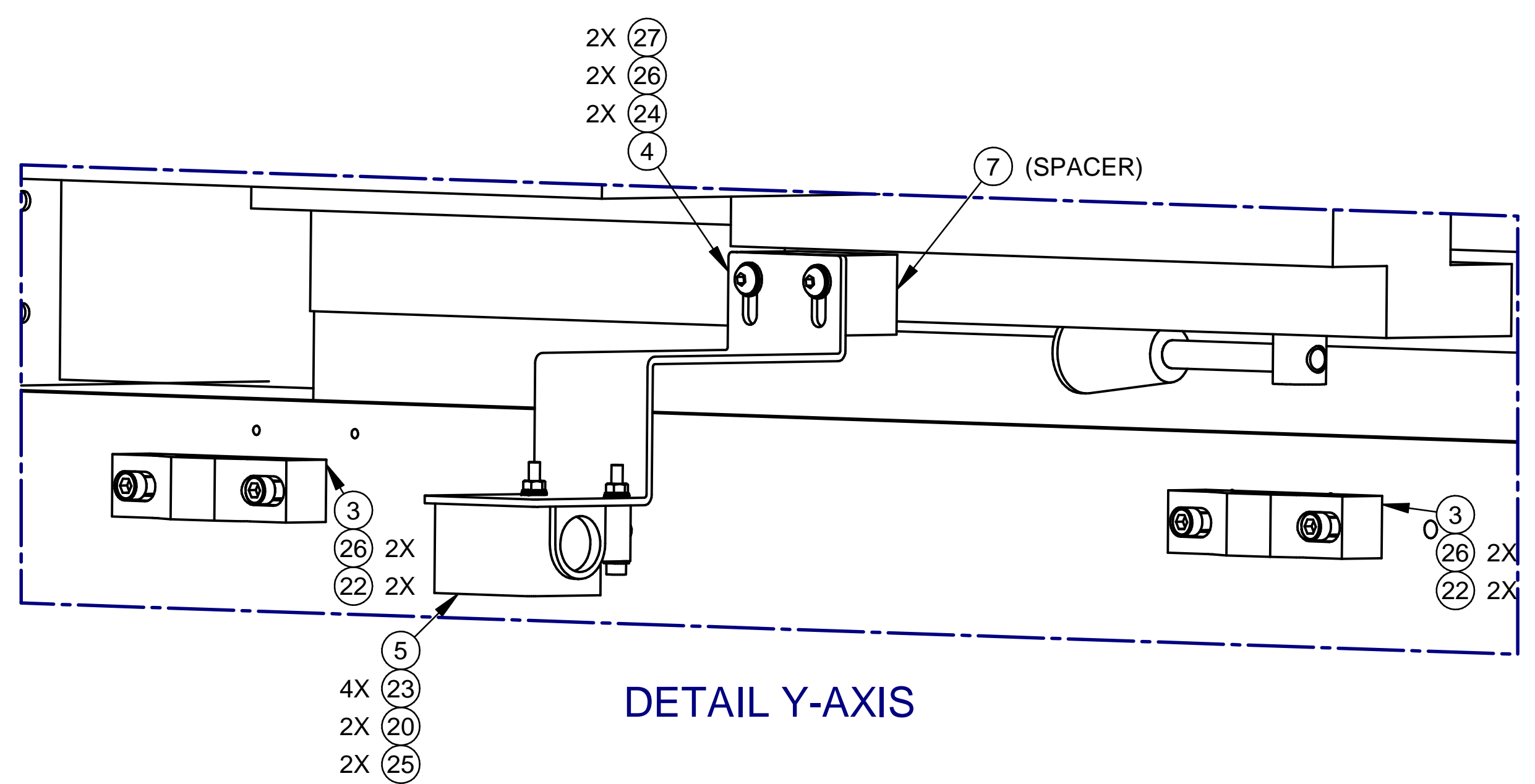

DETAIL Y-AXIS

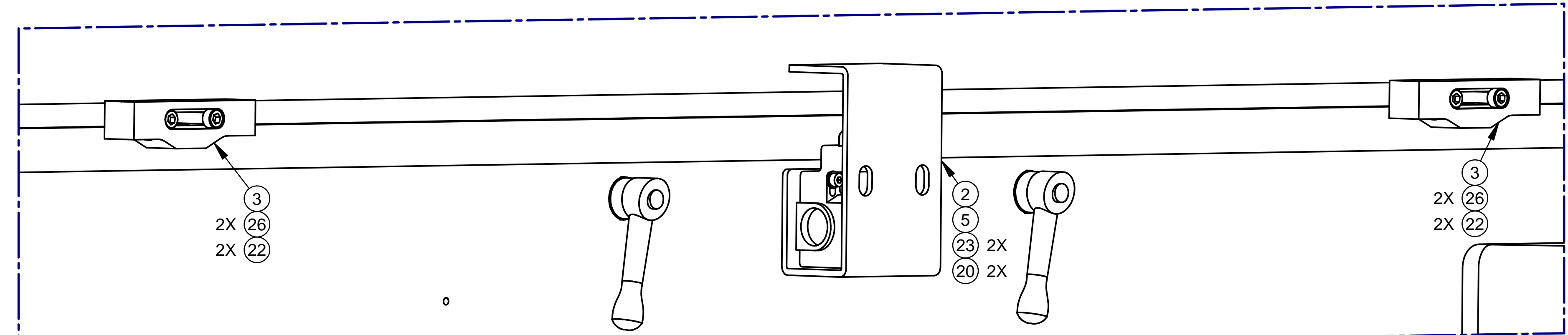

DETAIL X-AXIS

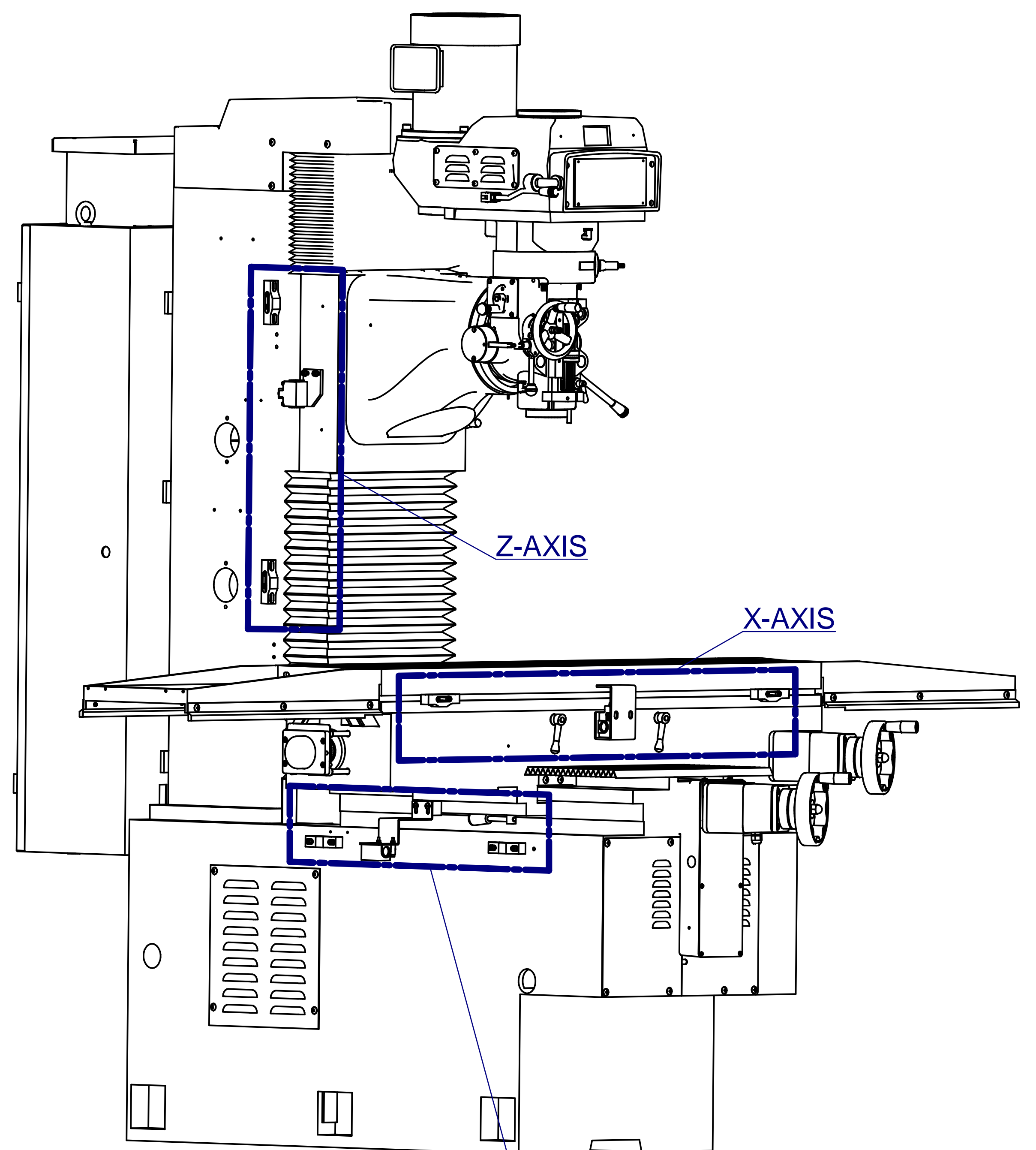

Z-AXIS

X-AXIS

Y-AXIS

DIMENSIONS ARE IN INCHES  
 DEC. .X = ±.1, .XX = ±.01, .XXX = ±.005  
 ANGLES .XX = +0°30'  
 FINISH = 125 RMS  
 REMOVE ALL SHARP EDGES  
 MASK ALL TAPPED HOLES  
 DIMENSIONING PER ASME Y14.5

MATERIAL	APPROVALS	DATE	TITLE	REV
	DRAWN BY JJ	04/26/22		
FINISH	ENGINEER JJ	04/26/22	LIMIT SWITCH KIT - DPM5	B
	CHECKER PB			
THIRD ANGLE PROJECTION			SIZE D	CODE IDENT. NO. 06238
			DWG NO. 29510-2	SHEET 1 OF 2



NOTICE: THIS DESIGN WAS ORIGINATED BY AND EMBODIES A CONFIDENTIAL PROPRIETARY DESIGN OWNED BY SOUTHWESTERN INDUSTRIES. IT IS DISCLOSED IN CONFIDENCE FOR A SPECIFIC PURPOSE AND THE RECIPIENT HEREOF AGREES NOT TO MAKE ANY REPRODUCTION, DISCLOSURE OR OTHER USE OF THIS INFORMATION WITHOUT THE WRITTEN CONSENT OF SOUTHWESTERN INDUSTRIES.  
© SOUTHWESTERN INDUSTRIES, INC. 2018 ALL RIGHT RESERVED

REVISIONS					
REV	DESCRIPTION	ECN	DATE	DFT	ENG
B	ADDED ITEM 16; ADDED BLOCK LARGE FONT LETTERS FOR LIMIT SWITCH FIXTURE IDENTIFICATION	16182	08/21/20	AF	JJ
C	29513-6 WAS: 29513-1, 29514-4 WAS: 29514-1	16655	04/29/22	AF	LG

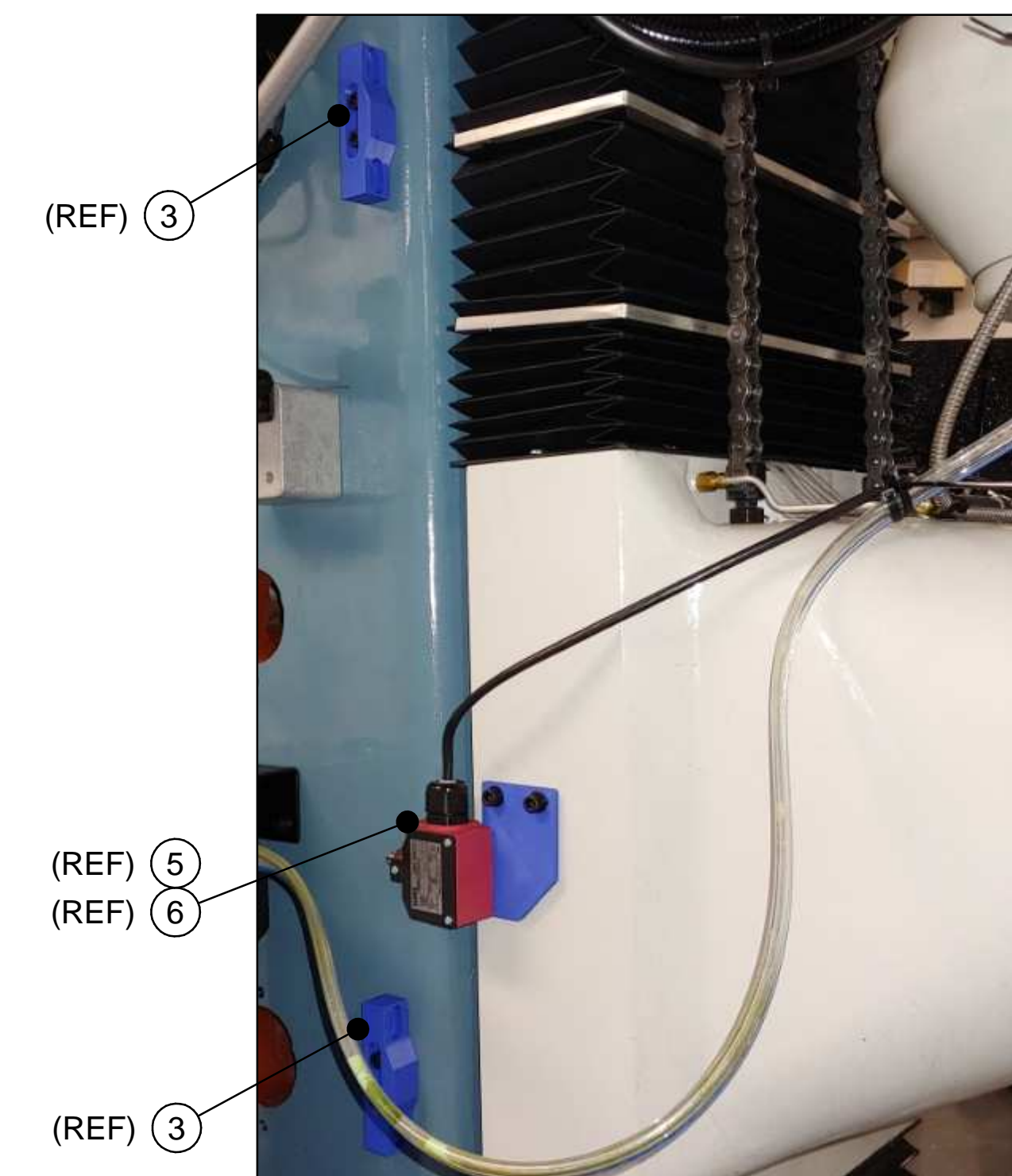
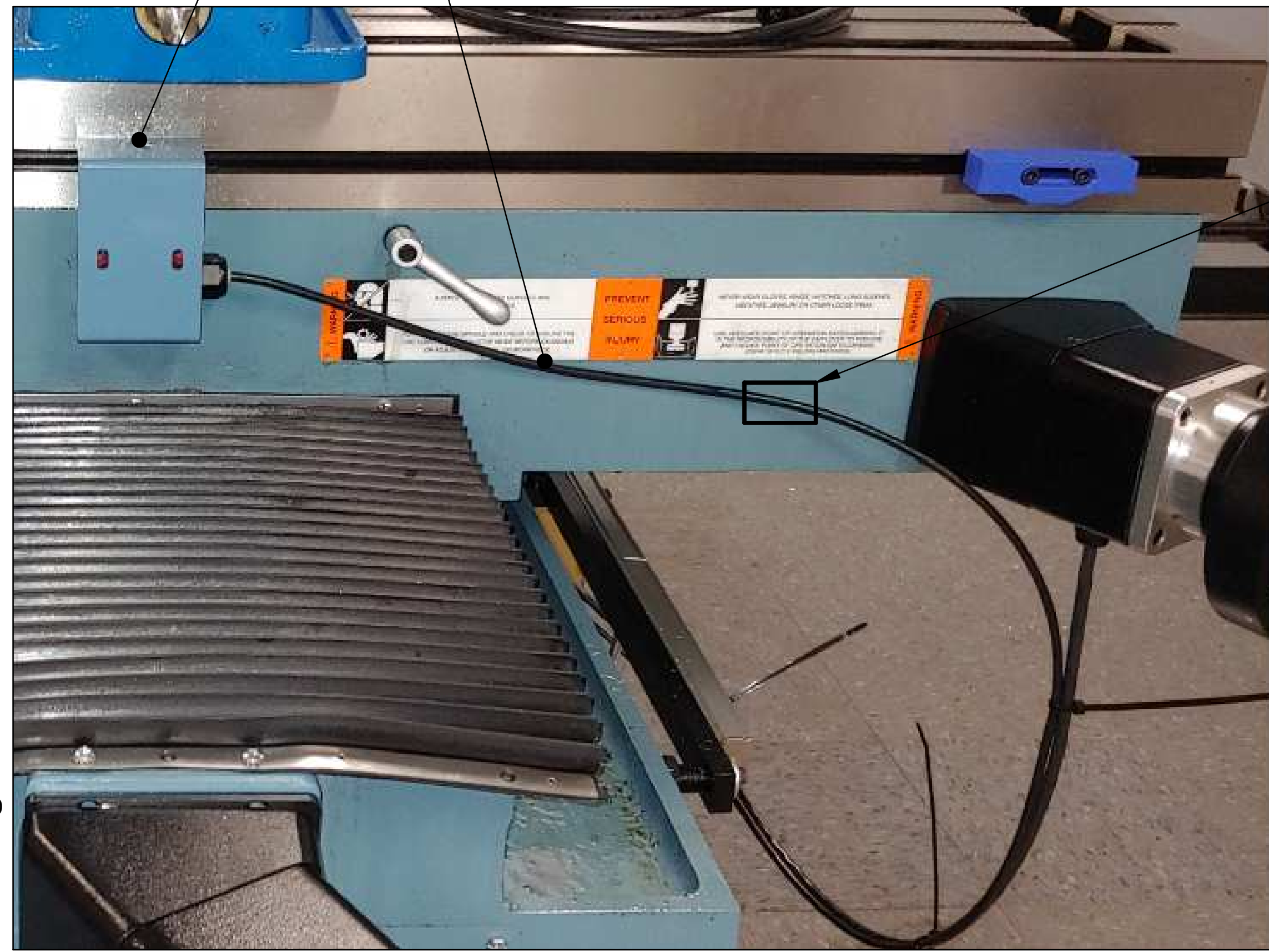
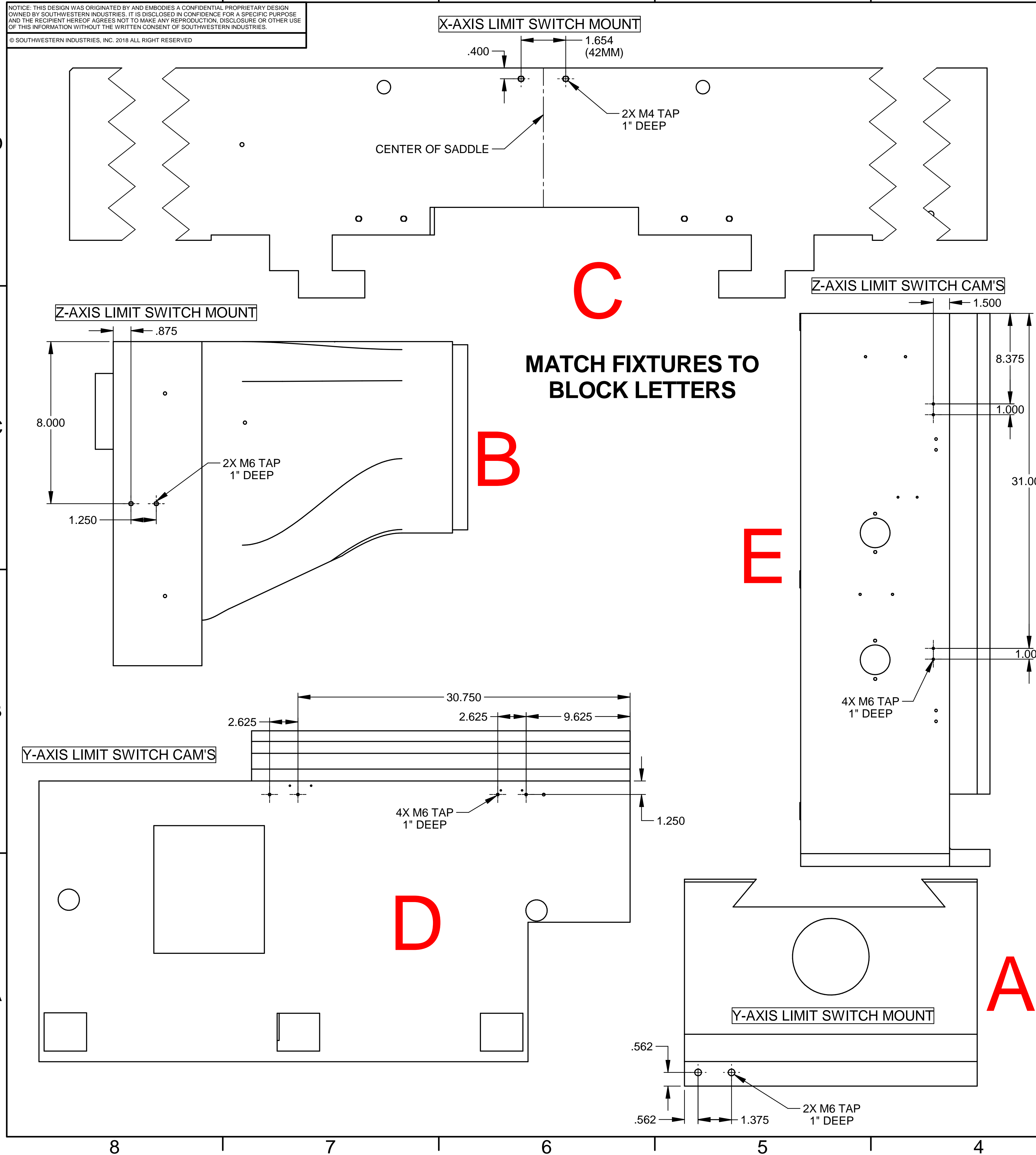

DIMENSIONS ARE IN INCHES DEC. .X = ±.1, .XX = ±.01, .XXX = ±.005 ANGLES .XX = ±0°30' FRACTIONS = ±1/8 FINISH = 125 RMS REMOVE ALL SHARP EDGES MASK ALL TAPPED HOLES DIMENSIONING PER ASME Y14.5		APPROVALS DRAWN BY JJ 04/26/22 ENGINEER JJ 04/26/22 CHECKER PB PE	DATE 04/26/22	TITLE <b>LIMIT SWITCH KIT - DPM5</b>
MATERIAL	FINISH	THIRD ANGLE PROJECTION	SIZE <b>D</b> CODE IDENT. NO. 06238 DWG NO. 29510-2 REV <b>B</b>	SCALE: SHEET 2 OF 2

Part Number: 29510-2

Revision: C

Drawn By: AF

Description: LIMIT SWITCH KIT -DPM5

Status: Released

Engineer: JJ

Date Created: 04/04/2018

REV	ECN/NPI #	DFT	ENG
C	ECN-16655	AF	LG
29513-6 WAS: 29513-1, 29514-4 WAS: 29514-1			

Detail:

Item	Part No.	Description	Detail	Qty	Type	BomUnit	Use As	Rev	Rec Type	MFG	MFG P/N	Status
1	22113	NUT-T SLOT-M6-1		4	Normal		EA	D	DWG	PJ		Released
2	29513-6	SHEET METAL-LIMIT SWITCH COVER X-AXIS DPM5		1	Normal		EA	A				Released
3	29512	CAM-LIMIT SWITCH	SW to Manage	6	Normal		EA	A.01	DWG			Non Controlled
4	29514-4	SHEET METAL-LIMIT SWITCH COVER Y-AXIS DPM3/5		1	Normal		EA	A				Released
5	22551-14	CABLE ASSY-LIMIT SWITCH		3	Normal		EA	A	PL			Released
6	29515	MOUNT - LIMIT SWITCH Z-AXIS DPM3/5		1	Normal		EA	A	DWG			Released
7	29509	SPACER-LIMIT SW MOUNT-Y AXIS		1	Reference		EA	A	DWG			Released
16	22637	CLAMP-HALF		1	Normal			-	DWG			Released
20	M4-0.7X35 25B	SCREW-SHCS-STL-BO		6	Normal		EA	A	PS			Released
21	M6-1.0X20 25B	SCREW-SHCS-STL-BO		6	Normal		EA	-	PS			Released
22	M6-1.0X25 25B	SCREW-SHCS-STL-BO		12	Normal		EA	A	PS			Released
23	M4 70B	WASHER-FLAT-STL-BO		8	Normal		EA	-	PS			Released
24	M6 70B	WASHER-FLAT USS-STL-BO		6	Normal		EA	-	PS			Released
25	M4-0.7 61Z	NUT-KEP-STL-ZINC		2	Normal		EA	-	PS			Released
26	24009-3	WASHER-BELLEVILLE SPRING LK-SERRATED	.264 ID x .374 OD x .024 THK-1/4 or M6	1	Normal		EA	D	DWG			Released
27	M6-1.0X40 27B	SCREW-BHCS-STL-BO		2	Normal		EA		PS			Released
28	29510-2-DOC	LIMIT SWITCH KIT -DPM5		1	Normal		EA	A	DOC			Released



NOTICE: THIS DESIGN WAS ORIGINATED BY AND EMBODIES A CONFIDENTIAL PROPRIETARY DESIGN OWNED BY SOUTHWESTERN INDUSTRIES. IT IS DISCLOSED IN CONFIDENCE FOR A SPECIFIC PURPOSE AND THE RECIPIENT HEREOF AGREES NOT TO MAKE ANY REPRODUCTION, DISCLOSURE OR OTHER USE OF THIS INFORMATION WITHOUT THE WRITTEN CONSENT OF SOUTHWESTERN INDUSTRIES.  
 © SOUTHWESTERN INDUSTRIES, INC. 2018 ALL RIGHT RESERVED

REVISIONS					
REV	DESCRIPTION	ECN	DATE	DFT	ENG
B	ADDED BLOCK LARGE FONT LETTERS FOR LIMIT SWITCH FIXTURE IDENTIFICATION	16182	06/10/20	AF	SC
C	29513-4 WAS: 29513, 29514-4 WAS: 29514-1	16655	04/29/22	AF	LG

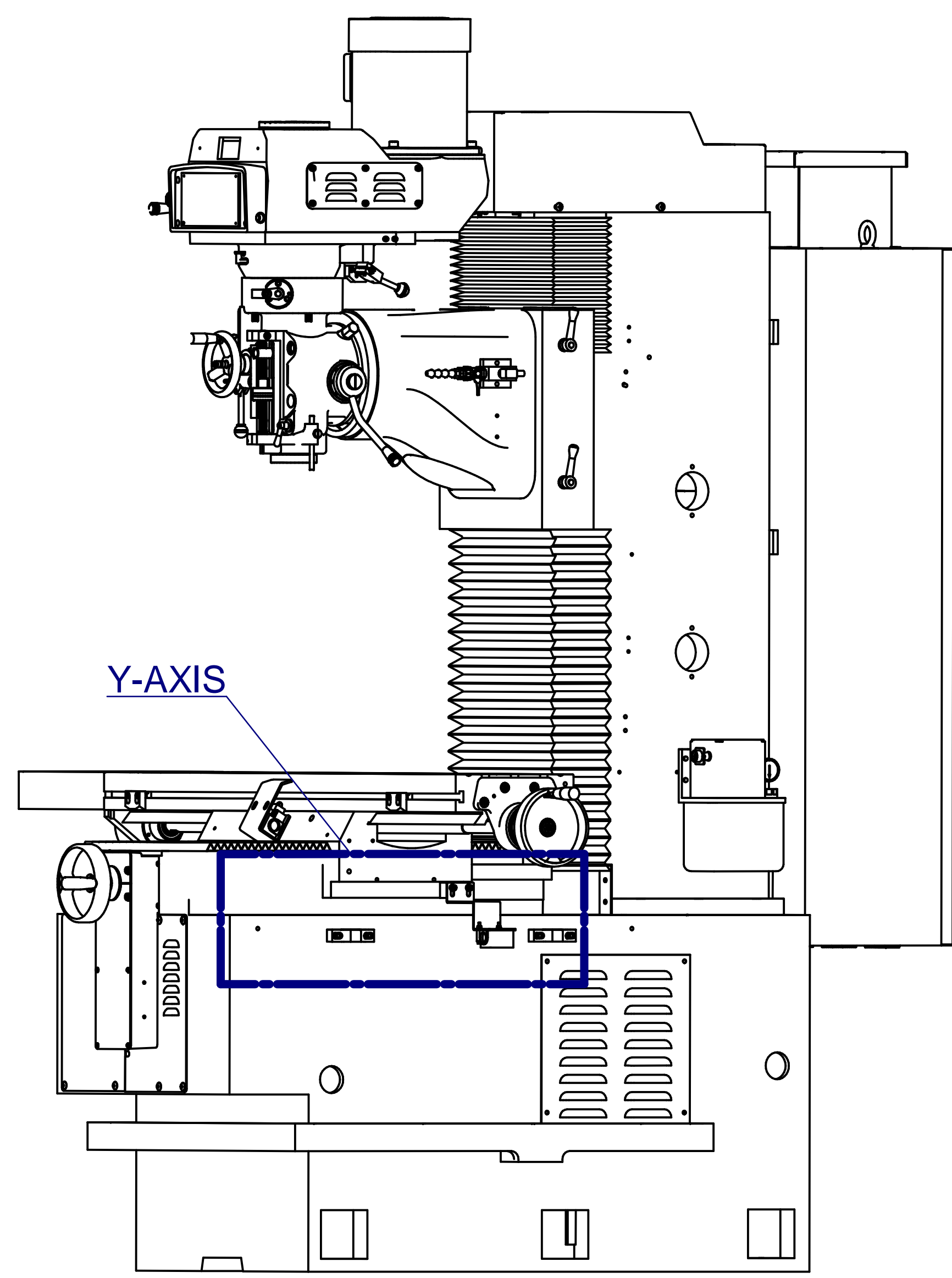

Y-AXIS

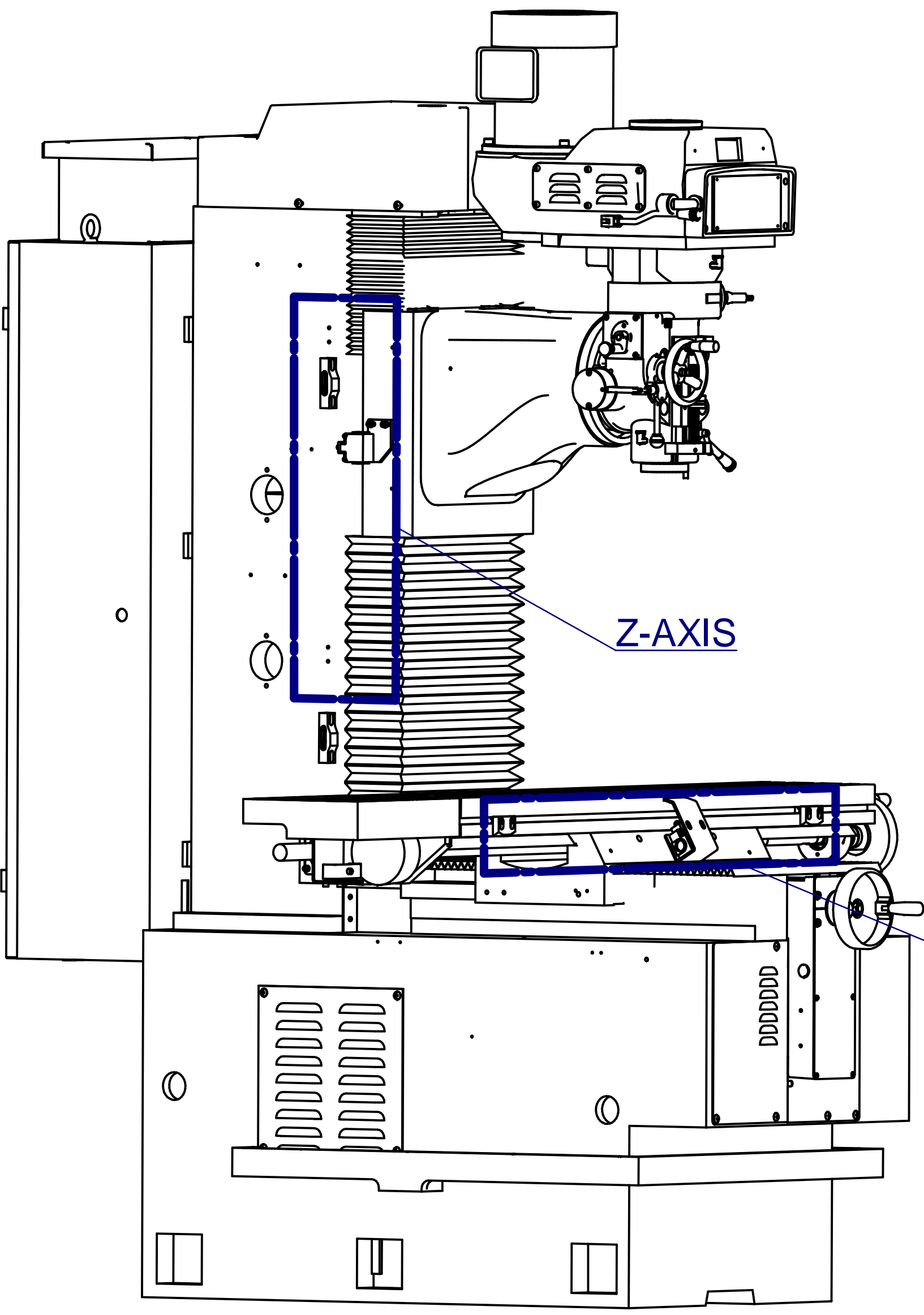

Z-AXIS

X-AXIS

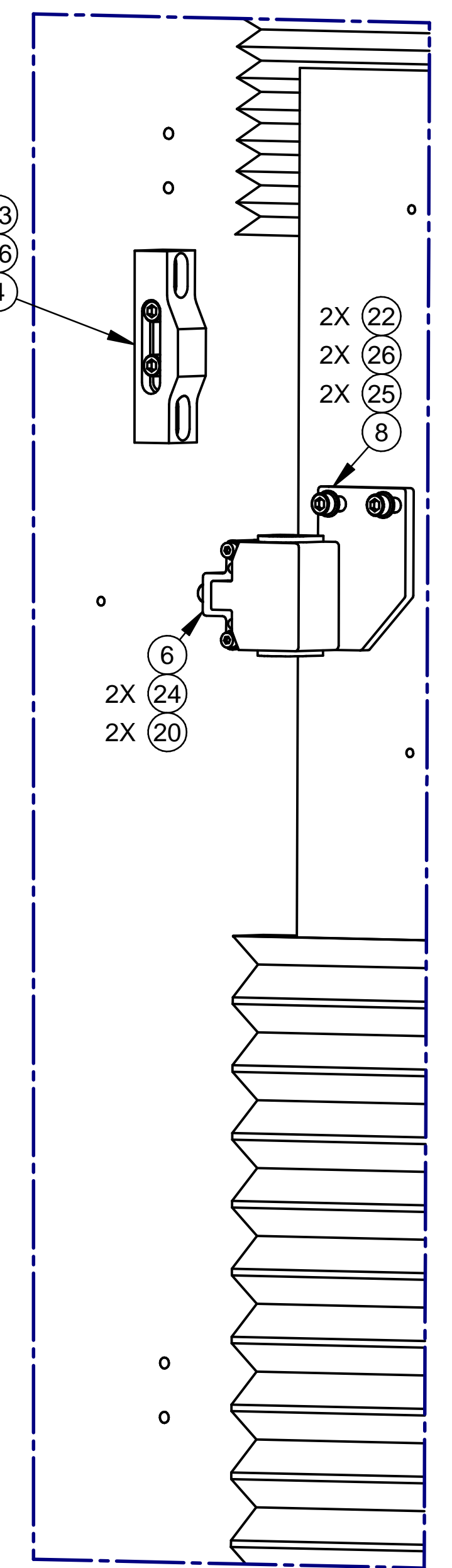

DETAIL Z-AXIS

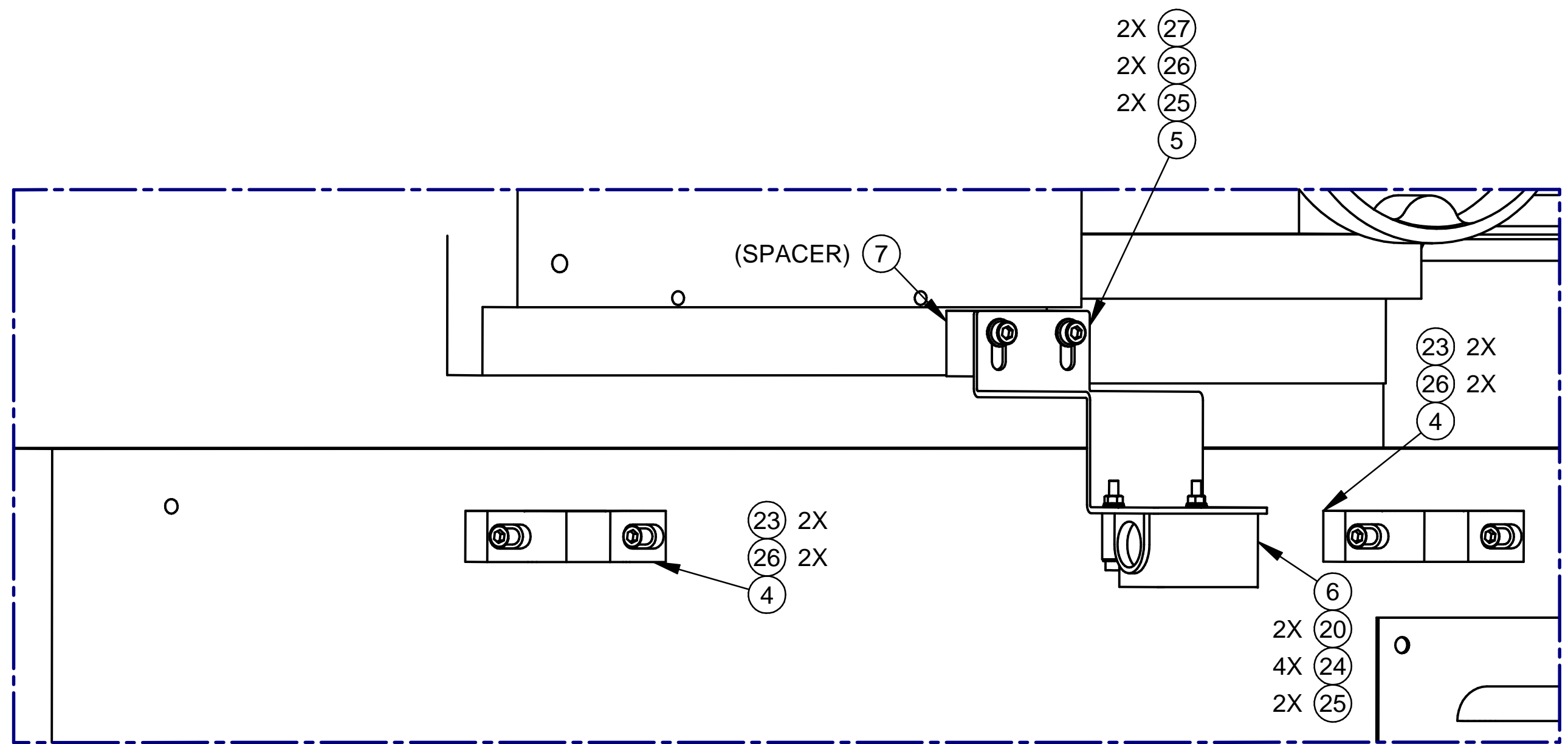

DETAIL Y-AXIS

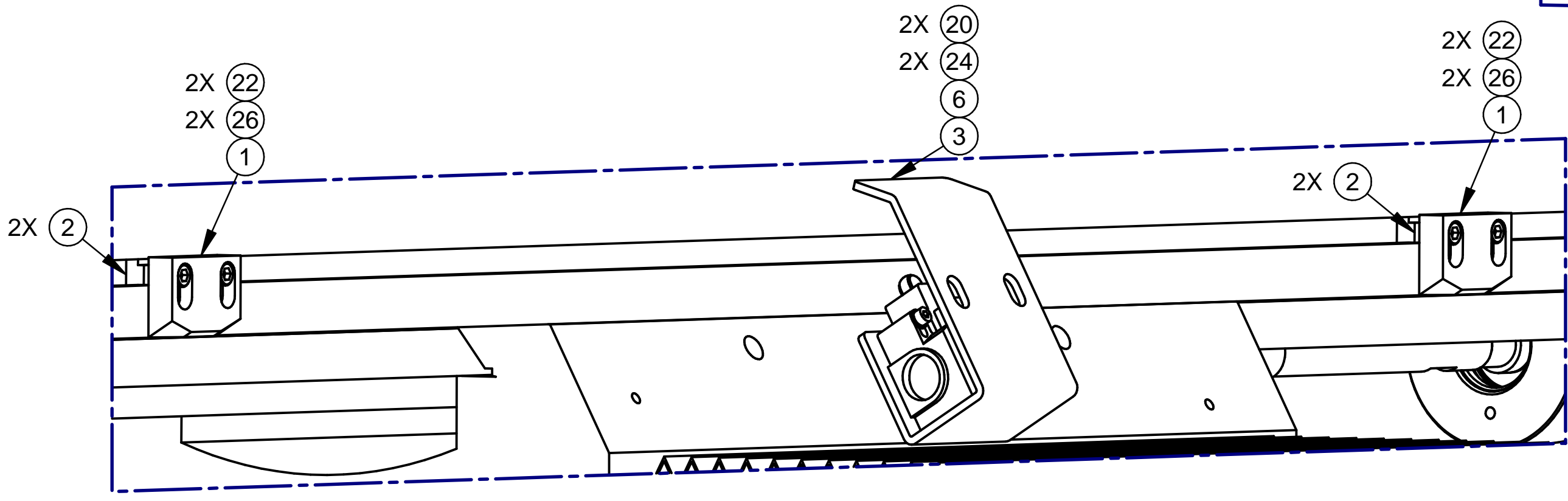

DETAIL X-AXIS

DIMENSIONS ARE IN INCHES  
 DEC. .X = ±.1, .XX = ±.01, .XXX = ±.005  
 ANGLES .XX = ±0°30'  
 FRACTIONS = ±1/8  
 FINISH = 125 RMS  
 REMOVE ALL SHARP EDGES  
 MASK ALL TAPPED HOLES  
 DIMENSIONING PER ASME Y14.5

APPROVALS		DATE			
DRAWN BY	JJ	04/26/22			
ENGINEER	JJ	04/26/22	TITLE		
CHECKER	PB		LIMIT SWITCH KIT - DPM3		
FINISH			SIZE	CODE IDENT. NO.	DWG NO.
			D	06238	29510-1
THIRD ANGLE PROJECTION			SCALE:		REV
					C
					SHEET 1 OF 2



NOTICE: THIS DESIGN WAS ORIGINATED BY AND EMBODIES A CONFIDENTIAL PROPRIETARY DESIGN OWNED BY SOUTHWESTERN INDUSTRIES. IT IS DISCLOSED IN CONFIDENCE FOR A SPECIFIC PURPOSE AND THE RECIPIENT HEREOF AGREES NOT TO MAKE ANY REPRODUCTION, DISCLOSURE OR OTHER USE OF THIS INFORMATION WITHOUT THE WRITTEN CONSENT OF SOUTHWESTERN INDUSTRIES.  
© SOUTHWESTERN INDUSTRIES, INC. 2018 ALL RIGHT RESERVED

REVISIONS					
REV	DESCRIPTION	ECN	DATE	DFT	ENG
B	ADDED BLOCK LARGE FONT LETTERS FOR LIMIT SWITCH FIXTURE IDENTIFICATION	16182	06/10/20	AF	SC
C	29513-4 WAS: 29513, 29514-4 WAS: 29514-1	16655	04/29/22	AF	LG

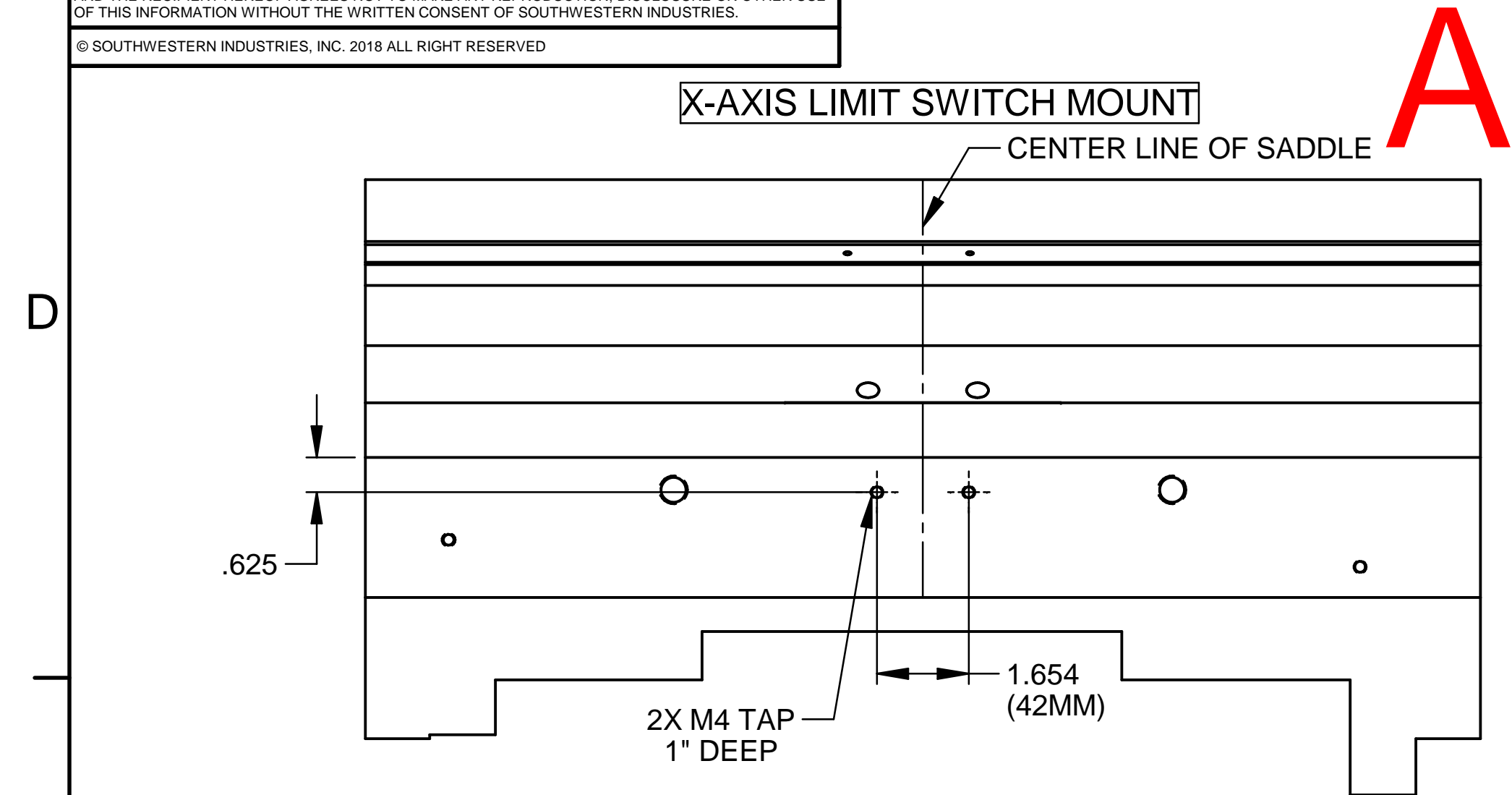

# MATCH FIXTURES TO BLOCK LETTERS

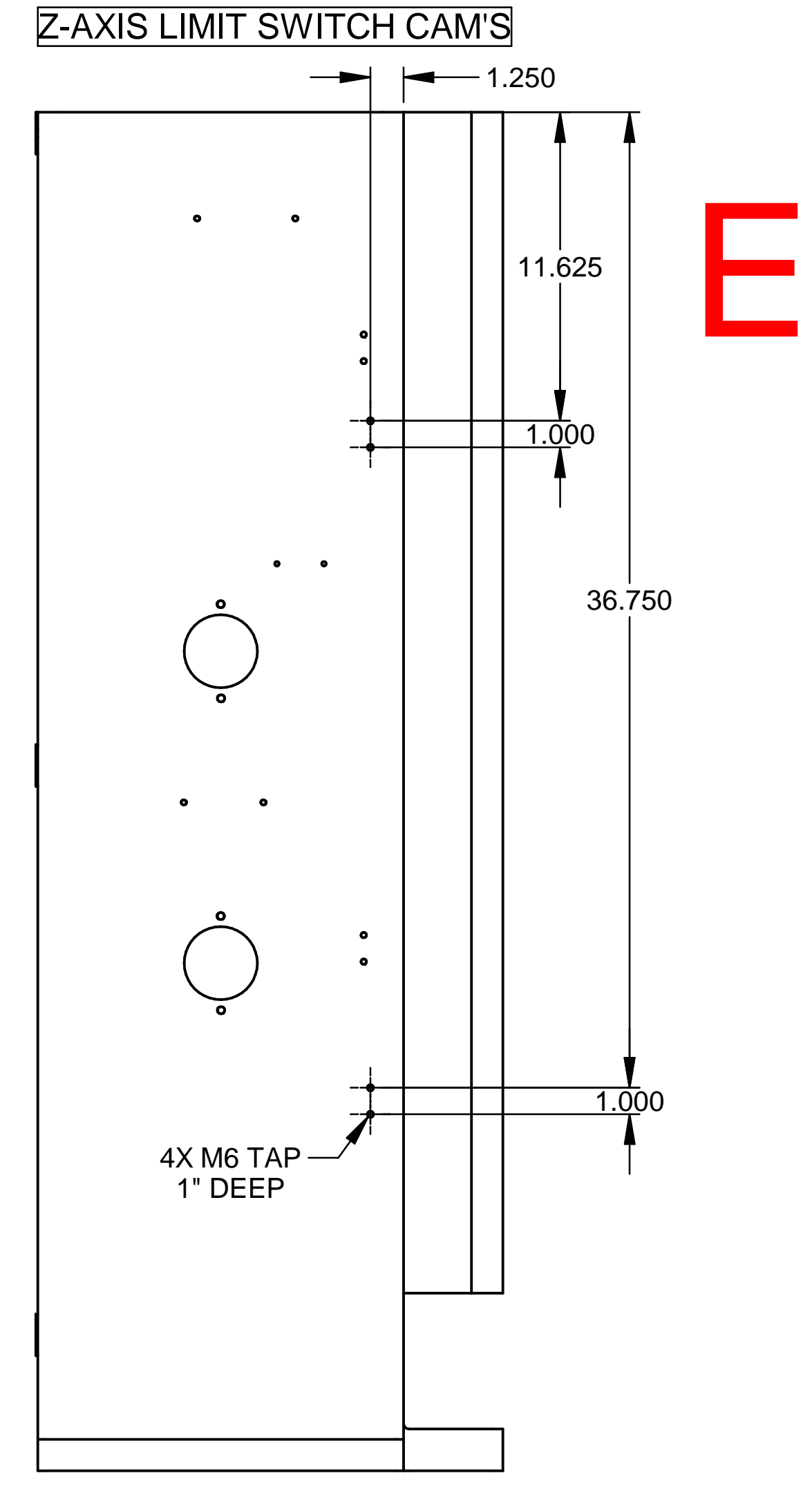
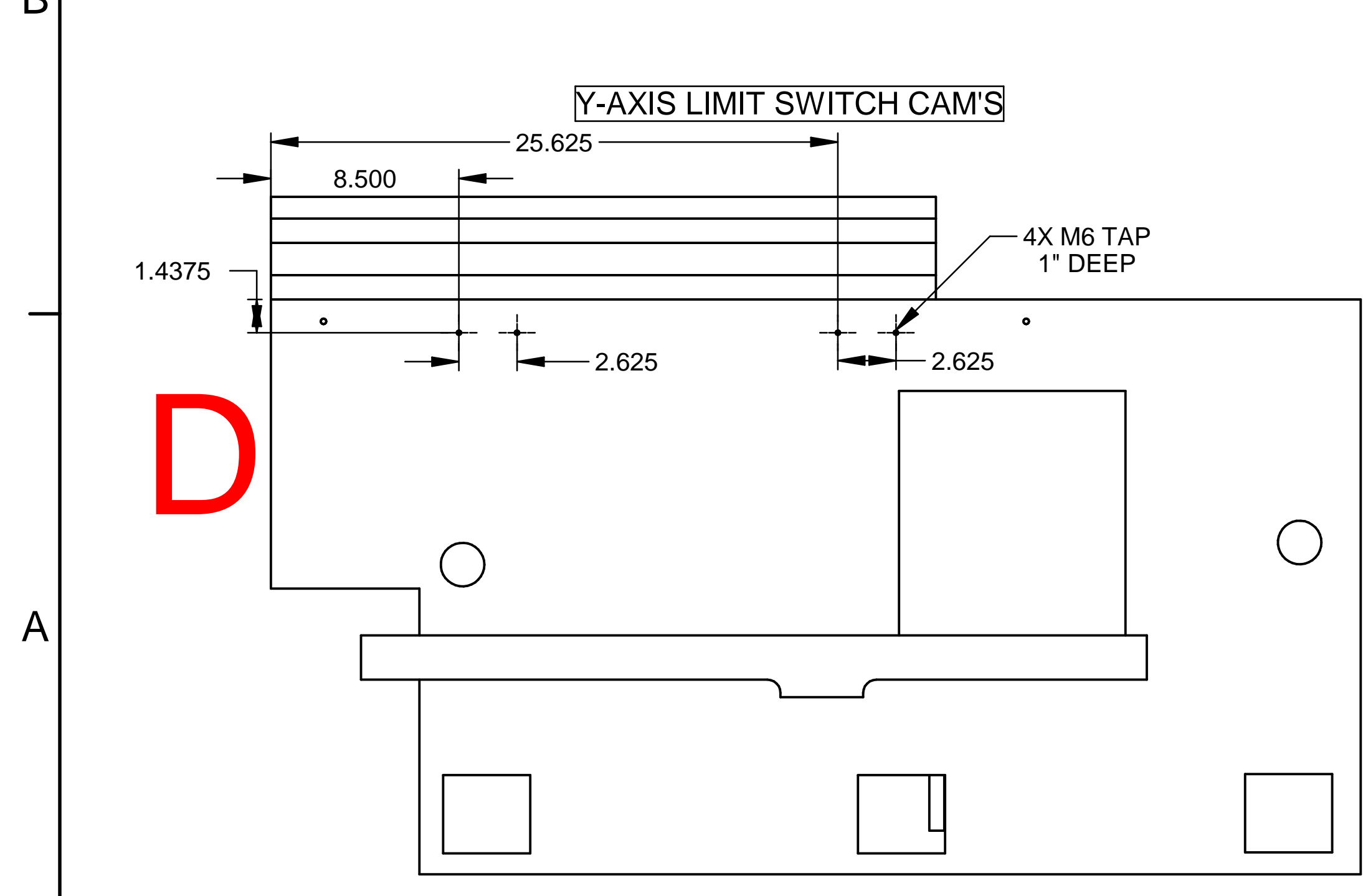
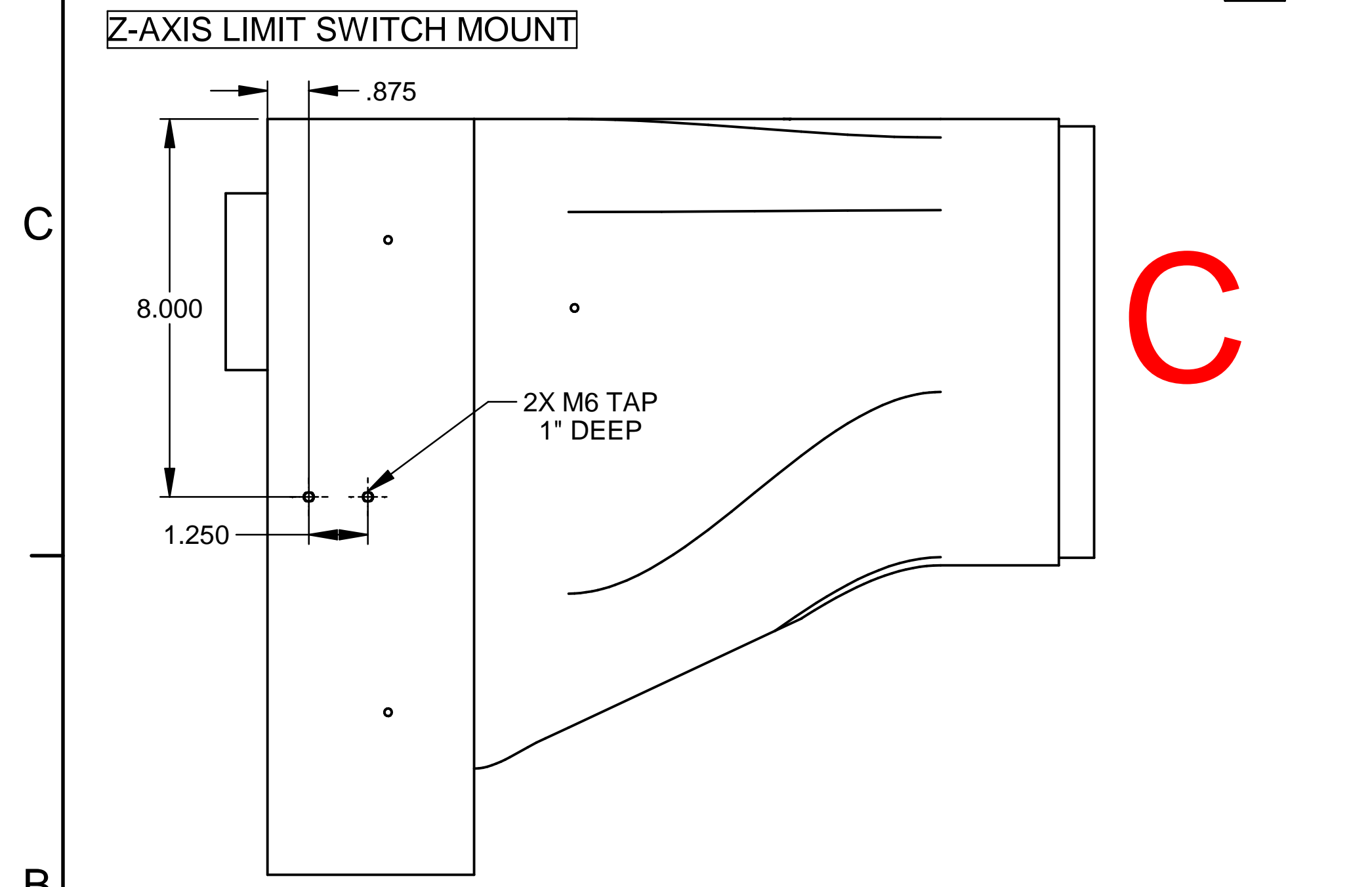
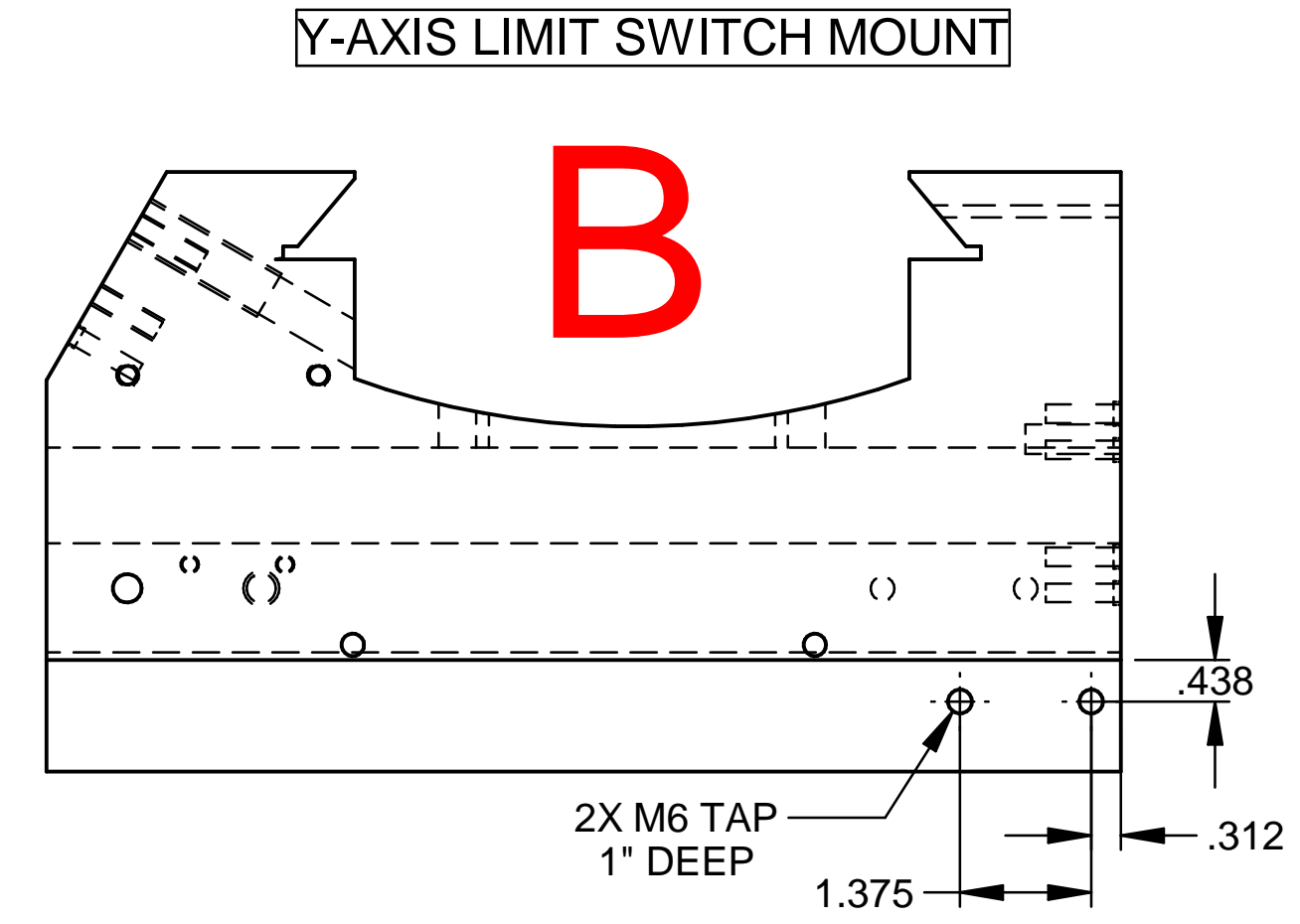

DIMENSIONS ARE IN INCHES  
DEC. .X = ±.1, .XX = ±.01, .XXX = ±.005  
ANGLES .XX = +0°30'  
FRACTIONS = ±1/8  
FINISH = 125 RMS  
REMOVE ALL SHARP EDGES  
MASK ALL TAPPED HOLES  
DIMENSIONING PER ASME Y14.5

APPROVALS		DATE	TITLE	
DRAWN BY	JJ	04/26/22	LIMIT SWITCH KIT - DPM3	
ENGINEER	JJ	04/26/22	TRAK MACHINE TOOLS	
CHECKER	PB		SHEET 2 OF 2	
FINISH	THIRD ANGLE PROJECTION	SIZE	CODE IDENT. NO.	DWG NO.
		D	06238	29510-1
		SCALE:		REV C



Part Number: 29510-1

Revision: C

Drawn By: AF

Description: LIMIT SWITCH KIT -DPM3

Status: Released

Engineer: SC

Date Created: 04/04/2018

REV	ECN/NPI #	DFT	ENG
C	ECN-16655	AF	LG
29513-4 WAS: 29513, 29514-4 WAS: 29514-1			

Detail:

Item	Part No.	Description	Detail	Qty	Type	BomUnit	Use As	Rev	Rec Type	MFG	MFG P/N	Status
1	29511	CAM-LIMIT SWITCH- X-AXIS DPM2/3		2	Normal		EA	A	DWG			Released
2	22113	NUT-T SLOT-M6-1		4	Normal		EA	D	DWG	PJ		Released
3	29513-4	SHEET METAL- LIMIT SWITCH COVER- X AXIS		1	Normal		EA	A				Released
4	29512	CAM-LIMIT SWITCH	SW to Manage	4	Normal		EA	A.01	DWG			Non Controlled
5	29514-4	SHEET METAL-LIMIT SWITCH COVER Y-AXIS DPM3/5		1	Normal		EA	A				Released
6	22551-14	CABLE ASSY-LIMIT SWITCH		3	Normal		EA	A	PL			Released
7	29509	SPACER-LIMIT SW MOUNT-Y AXIS		1	Reference		EA	A	DWG			Released
8	29515	MOUNT - LIMIT SWITCH Z-AXIS DPM3/5		1	Normal		EA	A	DWG			Released
9	PH4-8	CONNECTOR-		2	Normal		EA	-	PS			Released
10	22637	CLAMP-HALF		1	Normal		EA	-	DWG			Released
20	M4 70B	WASHER-FLAT-STL-BO		8	Normal		EA	-	PS			Released
21	M4-0.7 61Z	NUT-KEP-STL-ZINC		2	Normal		EA	-	PS			Released
22	M6-1.0X20 25B	SCREW-SHCS-STL-BO		4	Normal		EA	-	PS			Released
23	M6-1.0X25 25B	SCREW-SHCS-STL-BO		8	Normal		EA	A	PS			Released
24	M4-0.7X35 25B	SCREW-SHCS-STL-BO		6	Normal		EA	A	PS			Released
25	M6 70B	WASHER-FLAT USS-STL-BO		1	Normal		EA	-	PS			Released
26	24009-3	WASHER-BELLEVILLE SPRING LK-SERRATED	.264 ID x .374 OD x .024 THK-1/4 or M6	16	Normal		EA	D	DWG			Released
27	M6-1.0X40 27B	SCREW-BHCS-STL-BO		2	Normal		EA		PS			Released
28	10-32X3/8 31B	SCREW-PH-PHIL-EXT SEMS-STL-BO		1	Normal		EA	-	PS			Released
35	29510-1-DOC	LIMIT SWITCH KIT -DPM3		1	Normal		EA	A	PL			Released



NOTICE: THIS DESIGN WAS ORIGINATED BY AND EMBODIES A CONFIDENTIAL PROPRIETARY DESIGN OWNED BY SOUTHWESTERN INDUSTRIES. IT IS DISCLOSED IN CONFIDENCE FOR A SPECIFIC PURPOSE AND THE RECIPIENT HEREOF AGREES NOT TO MAKE ANY REPRODUCTION, DISCLOSURE OR OTHER USE OF THIS INFORMATION WITHOUT THE WRITTEN CONSENT OF SOUTHWESTERN INDUSTRIES.  
 © SOUTHWESTERN INDUSTRIES, INC. 2018 ALL RIGHT RESERVED

REVISIONS					
REV	DESCRIPTION	ECN	DATE	DFT	ENG
B	ADDED ITEM 10; ADDED BLOCK LARGE FONT LETTERS FOR LIMIT SWITCH FIXTURE IDENTIFICATION	16185	08/28/20	AF	JJ
C	29513-4 WAS: 29513, 29514-3 WAS: 29514; M4-0.7 56Z QTY WAS: 1	16655	04/29/22	AF	LG

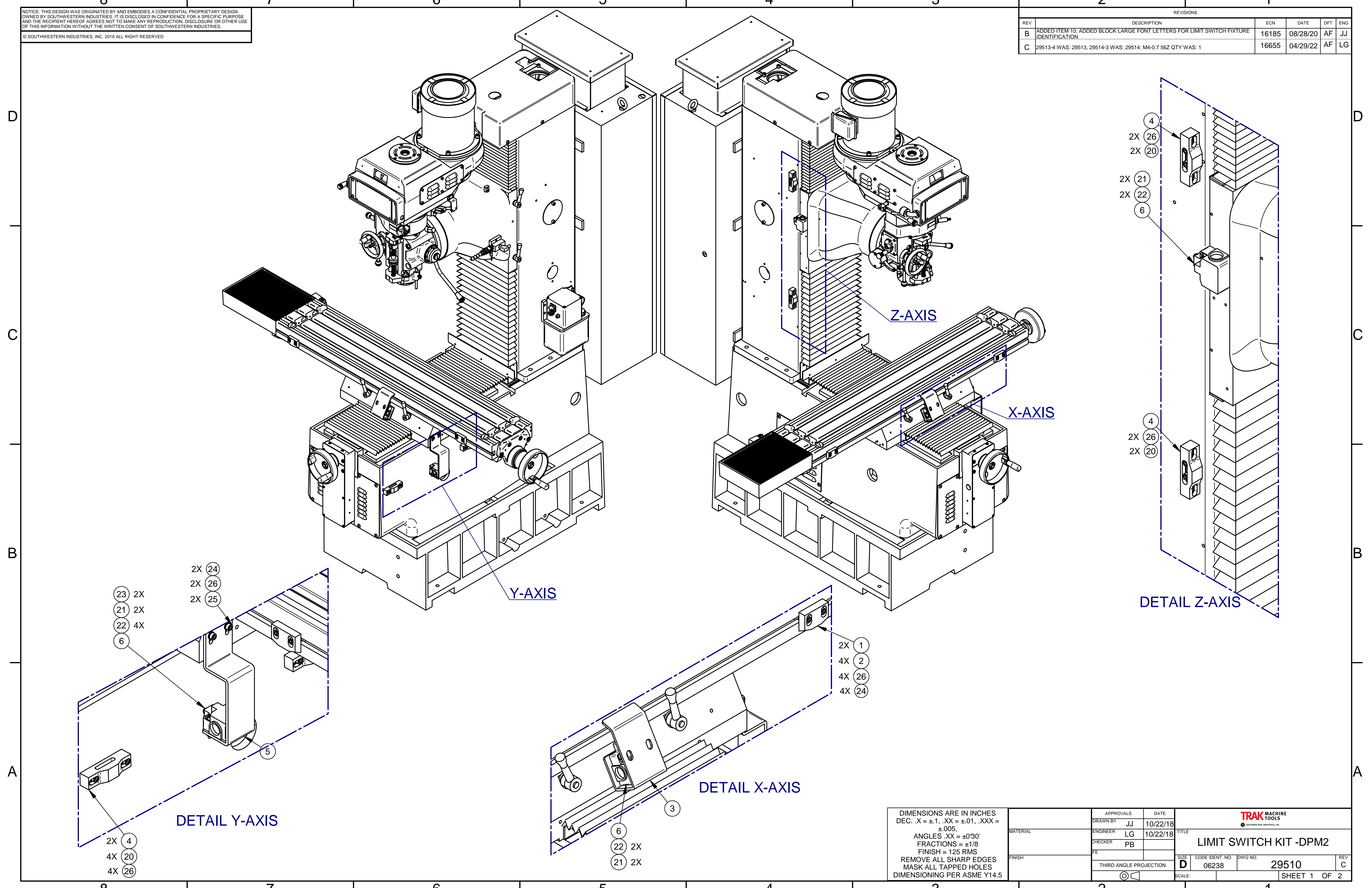

DIMENSIONS ARE IN INCHES  
 DEC. .X = ±.1, .XX = ±.01, .XXX = ±.005  
 ANGLES .XX = +0°30'  
 FRACTIONS = ±1/8  
 FINISH = 125 RMS  
 REMOVE ALL SHARP EDGES  
 MASK ALL TAPPED HOLES  
 DIMENSIONING PER ASME Y14.5

APPROVALS		DATE		
DRAWN BY	JJ	10/22/18	TITLE	
ENGINEER	LG	10/22/18	LIMIT SWITCH KIT -DPM2	
CHECKER	PB		SIZE	CODE IDENT. NO.
PE			D	06238
			DWG NO.	29510
			REV	C
THIRD ANGLE PROJECTION			SCALE:	SHEET 1 OF 2



NOTICE: THIS DESIGN WAS ORIGINATED BY AND EMBODIES A CONFIDENTIAL PROPRIETARY DESIGN OWNED BY SOUTHWESTERN INDUSTRIES. IT IS DISCLOSED IN CONFIDENCE FOR A SPECIFIC PURPOSE AND THE RECIPIENT HEREOF AGREES NOT TO MAKE ANY REPRODUCTION, DISCLOSURE OR OTHER USE OF THIS INFORMATION WITHOUT THE WRITTEN CONSENT OF SOUTHWESTERN INDUSTRIES.  
 © SOUTHWESTERN INDUSTRIES, INC. 2018 ALL RIGHT RESERVED

REV		DESCRIPTION	ECN	DATE	DFT	ENG
B	ADDED ITEM 10; ADDED BLOCK LARGE FONT LETTERS FOR LIMIT SWITCH FIXTURE IDENTIFICATION	16185	08/28/20	AF	JJ	
C	29513-4 WAS: 29513, 29514-3 WAS: 29514; M4-0.7 56Z QTY WAS: 1	16655	04/29/22	AF	LG	

# MATCH FIXTURES TO BLOCK LETTERS

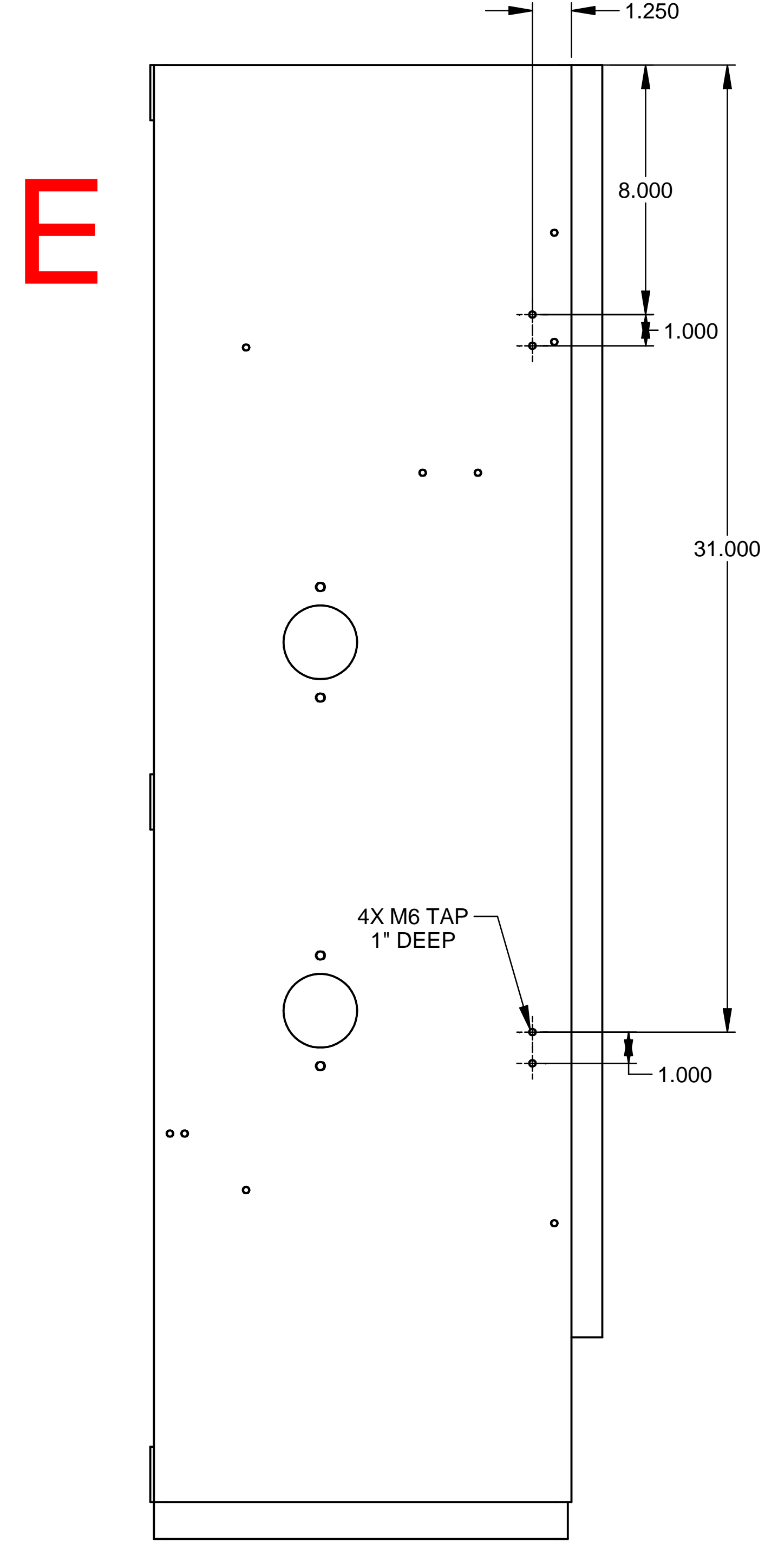
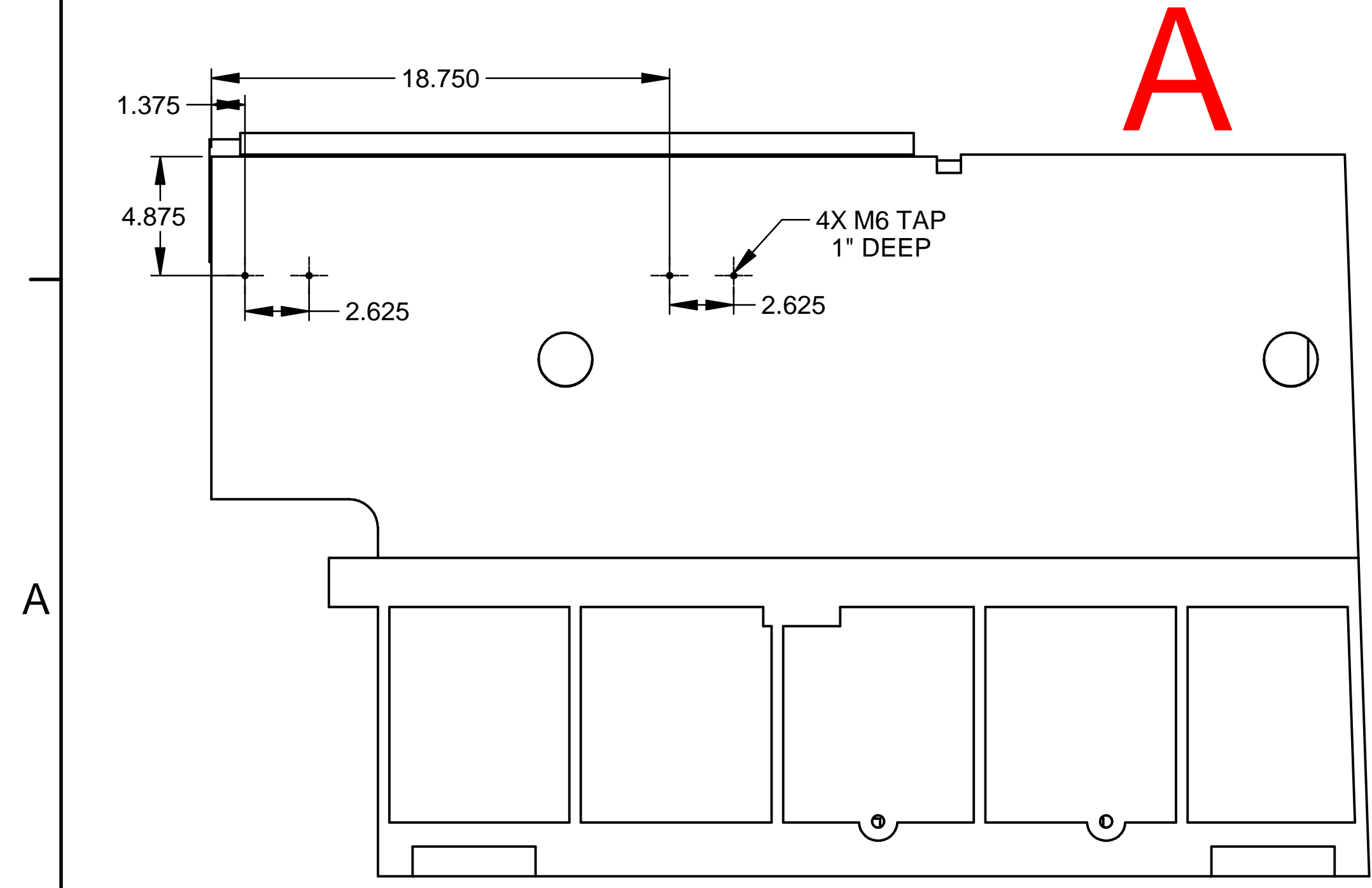
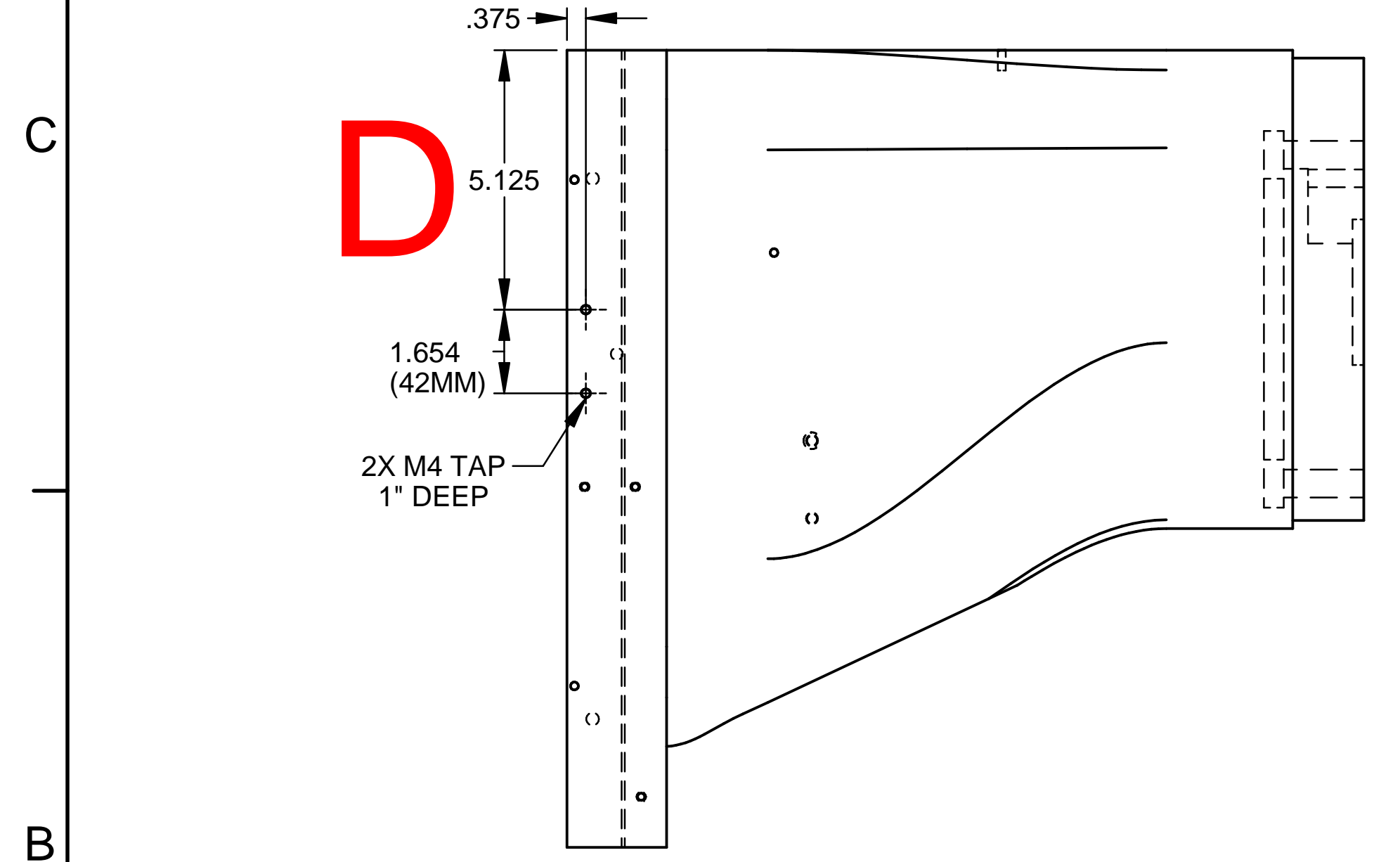
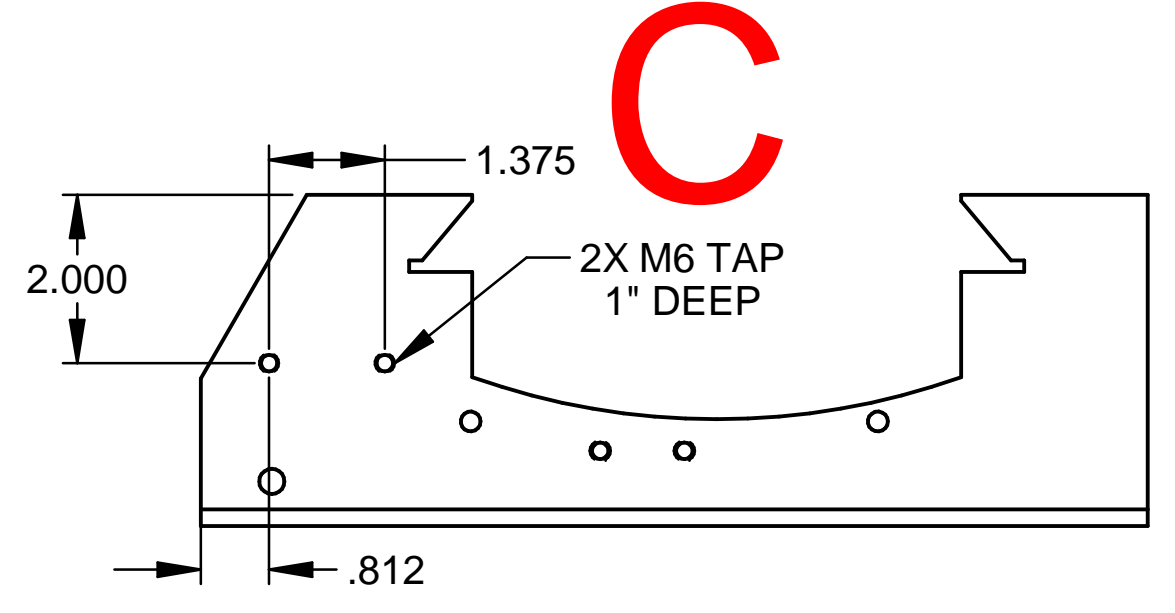
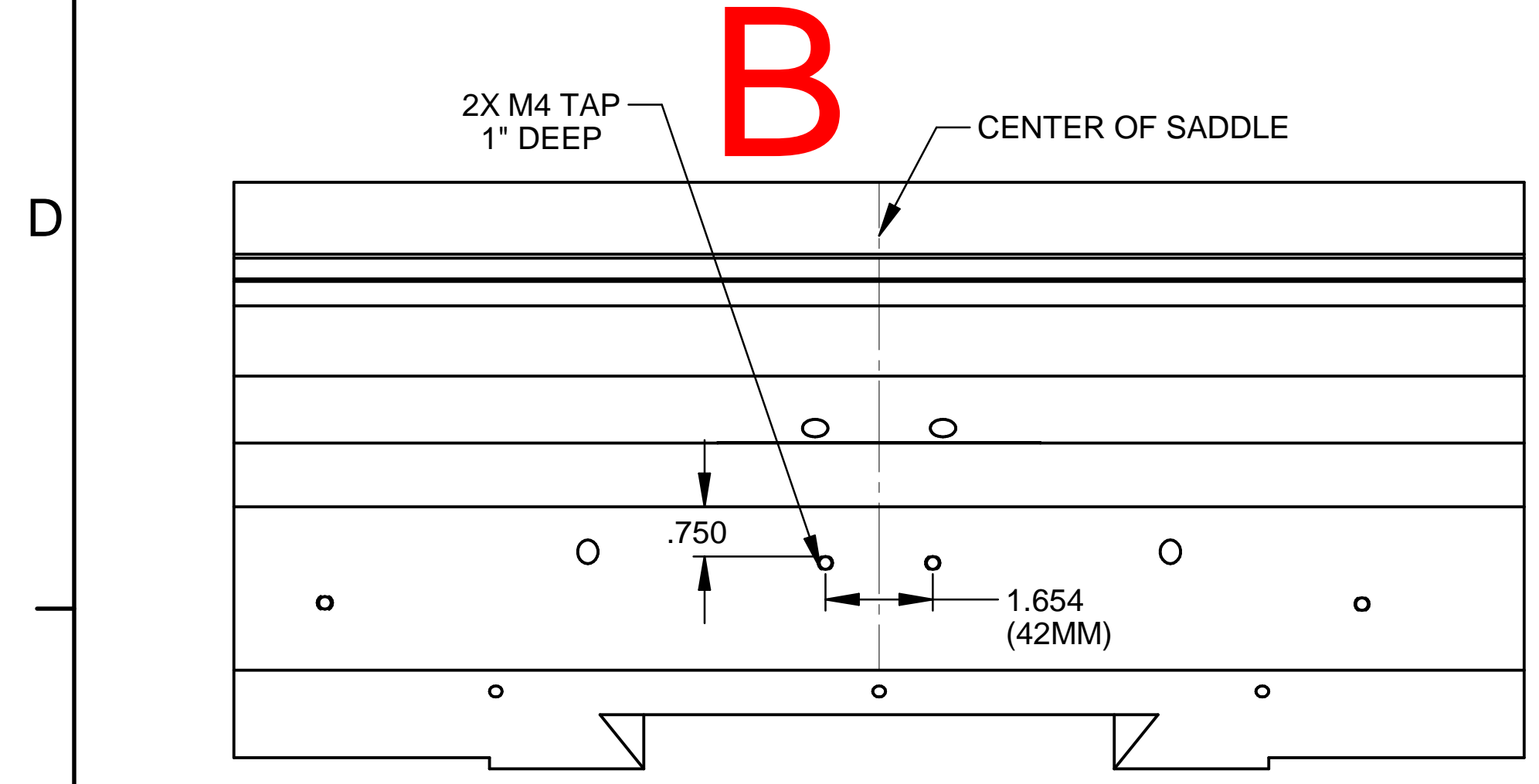

DIMENSIONS ARE IN INCHES  
 DEC. .X = ±.1, .XX = ±.01, .XXX = ±.005  
 ANGLES .XX = +0°30'  
 FRACTIONS = ±1/8  
 FINISH = 125 RMS  
 REMOVE ALL SHARP EDGES  
 MASK ALL TAPPED HOLES  
 DIMENSIONING PER ASME Y14.5

APPROVALS		DATE	TITLE			
DRAWN BY	JJ	10/22/18	LIMIT SWITCH KIT -DPM2			
ENGINEER	LG	10/22/18				
CHECKER	PB					
THIRD ANGLE PROJECTION		SCALE: $\frac{D}{1}$	SIZE: <b>D</b>	CODE IDENT. NO.: 06238	DWG NO.: 29510	REV: C





Part Number: 29510

Description: LIMIT SWITCH KIT -DPM2

Detail:

Revision: C

Status: Released

Date Created: 03/29/2018

Drawn By: AF

Engineer: JJ

REV	ECN/NPI #	DFT	ENG
C	ECN-16655	AF	LG
29513-4 WAS: 29513, 29514-3 WAS: 29514; M4-0.7 56Z QTY WAS: 1			

Item	Part No.	Description	Detail	Qty	Type	BomUnit	Use As	Rev	Rec Type	MFG	MFG P/N	Status
1	29511	CAM-LIMIT SWITCH- X-AXIS DPM2/3		2	Normal		EA	A	DWG			Released
2	22113	NUT-T SLOT-M6-1		4	Normal		EA	D	DWG	PJ		Released
3	29513-4	SHEET METAL- LIMIT SWITCH COVER- X AXIS		1	Reference		EA	A				Released
4	29512	CAM-LIMIT SWITCH	SW to Manage	4	Normal		EA	A.01	DWG			Non Controlled
5	29514-3	SHEET METAL-LIMIT SWITCH COVER Y-AXIS DPM2		1	Reference		EA	A				Released
6	22551-14	CABLE ASSY-LIMIT SWITCH		3	Reference		EA	A	PL			Released
10	22637	CLAMP-HALF		1	Reference			-	DWG			Released
20	M6-1.0X25 25B	SCREW-SHCS-STL-BO		8	Normal		EA	A	PS			Released
21	M4-0.7X35 25B	SCREW-SHCS-STL-BO		6	Normal		EA	A	PS			Released
22	M4 70B	WASHER-FLAT-STL-BO		8	Normal		EA	-	PS			Released
23	M4-0.7 56Z	NUT-NYLON LOCK-STL-ZINC		2	Normal		EA		PS			Released
24	M6-1.0X20 25B	SCREW-SHCS-STL-BO		6	Normal		EA	-	PS			Released
25	M6 70B	WASHER-FLAT USS-STL-BO		1	Normal		EA	-	PS			Released
26	24009-3	WASHER-BELLEVILLE SPRING LK-SERRATED	.264 ID x .374 OD x .024 THK-1/4 or M6	14	Normal		EA	D	DWG			Released
27	29510-DOC	LIMIT SWITCH KIT -DPM2		1	Normal		EA	A	DOC			Released