

TRAK® 3ntr 3D Printers

Maintenance Manual V1.18

Document:	P/N 32237
Version:	112019

Covers Current Models:

- **3ntr A2**
- **3ntr A4**

TRAK MACHINE
TOOLS



SOUTHWESTERN INDUSTRIES, INC.

2615 Homestead Place

Rancho Dominguez, CA 90220-5610 USA

T | 310.608.4422 | F | 310.764.2668

Service Department: 800.367.3165

e-mail: sales@trakmt.com | service@trakmt.com | web: www.trakmt.com

Copyright © 2019, Southwestern Industries, Inc. All rights are reserved. No part of this publication may be reproduced, stored in a retrieval system, or transmitted, in any form or by any means, mechanical, photocopying, recording or otherwise, without the prior written permission of Southwestern Industries, Inc.

While every effort has been made to include all the information required for the purposes of this guide, Southwestern Industries, Inc. assumes no responsibility for inaccuracies or omission and accepts no liability for damages resulting from the use of the information contained in this guide.

All brand names and products are trademarks or registered trademarks of their respective holders.

Southwestern Industries, Inc.
2615 Homestead Place
Rancho Dominguez, CA 90220
Phone 310-608-4422 Fax 310-764-2668
Service Department
Phone 800-367-3165 Fax 310-886-8029

Table of Contents

1	Introduction	1
2	Safety.....	2
2.1	Safety Precautions.....	2
3	Main Diagnostic Checklist.....	4
4	Repair Procedures	6
4.1	No Power Diagnostic Flowchart	6
4.2	No Power Check.....	7
4.3	Fuse is blown repeatedly	12
4.4	Mother Board Cabling	12
4.5	Cooling Circuit – Maintenance Flow Chart	20
4.6	Cooling Circuit – Drain System	21
4.7	Cooling Circuit – Fix Bent Piping	25
4.8	Cooling Circuit - Cleaning	28
4.9	Cooling Circuit – Pump Cleaning	31
4.10	Pulleys.....	34
4.11	Heat Exchanger Cleaning.....	36
4.12	Stepper Heat Sinks – Cleaning	37
4.13	Belt Tension	38
4.14	Heated Chamber Diagnostic Flowchart	39
4.15	Heated Chamber Inspect & Repair	40
4.16	Screw Terminals - Tighten.....	44
4.17	DC Fans – Inspect	46
4.18	Extruder Gain – How to Find	47
4.19	DC Power Supply Test.....	47
4.20	Stepper Current Setting (OLD Stepper Drivers).....	49
4.21	Stepper Current Settings (Silent Drivers)	50
4.22	Stepper Driver Replacement.....	51
4.23	Feed Pressure – Check/Restore to Factory Default	52

4.24 LCD Display Malfunction – Weird Character Display.....	52
4.25 Z Motor Replacement.....	53
4.26 Heated Chamber – A4 Printer Heater Replacement.....	53
4.27 Front Panel Removal.....	55
4.28 Machine Packaging	58
4.29 Extruder Plate Change.....	62
4.30 Print Plate Repair Procedure	65
4.31 Very High Temperature Hardware/Firmware Modification	72
4.32 Print Server Stops Working	75
4.33 Print Server – Lost Password.....	75
4.34 Print Server – Files Disappeared	75
4.35 Print Server – Files are Visible, but Won’t Print.....	77
4.36 Print Server – Firmware won’t flash anymore	79
4.37 Filament Sensor Doesn’t Work/Works Intermittently	79
4.38 Printer Jams frequently – Cooling Circuit jammed	80
4.39 Print Looks Bad – Stripes.....	83
4.40 X/Y/Z Axis Won’t Move	84
4.41 Z Safety Switch Installation/Calibration.....	85
4.42 Z Safety Switch is triggered – machine is locked	86
4.43 Appendix A – Testing for Shorts (Continuity)	86
4.44 Appendix B – How to Test Voltage	89
4.45 Appendix C: Changelog.....	91
5 TRAK Warranty Policy.....	92

1 Introduction

This Maintenance Guide contains information to assist skilled and trained technicians in the maintenance, troubleshooting, and repair of the TRAK 3ntr 3D printers. It is far from complete; however, directly addresses the most commonly encountered issues that require maintenance, service, and/or troubleshooting with the TRAK 3NTR A2/A4 3D Printers.

Scope of the Maintenance Manual:

- Diagnostic Checklists/Flowcharts
- Repair Procedures
- Maintenance Procedures
- Upgrade Procedures

Although there is a Main Diagnostic Checklist available as a starting point for printer troubleshooting, this guide is most efficiently utilized browsing the table of contents to select the applicable Repair Procedures section content.

CAUTION - Information contained within this manual is a reminder for trained personnel only. This manual does NOT replace training – untrained personnel should not perform any maintenance on any 3ntr machinery even if dutifully following the procedures depicted into this document.

2 Safety

The safe set-up, calibration, and operation of your TRAK 3ntr 3D printer depends on its proper use and precautions taken by each operator. If these activities are performed incorrectly, there are risks, not limited to, electric shock, pinch/crush, burns, inhalation of fumes/debris that can cause serious injury or death.

NOTE –Southwestern Industries shall not be liable for damages resulting from mis-interpretation, misuse, error, and/or omission of the information contained within this manual.

Read and follow this Maintenance Guide. Understand the printer operation and safety precautions before setting up, calibrating, or operating the 3D printer.

- Always wear safety glasses and safety shoes.
- Always stop the printer before opening the access door and reaching into the printer.
- Always allow the printer, printer surface plate and workpiece to cool adequately before reaching into the printer.
- Have a qualified electrician make all electrical connections and cable wiring
- Never wear gloves, rings, watches, long sleeves, neckties, jewelry, or other loose items when operating the printer.

2.1 Safety Precautions

- 1) Do not operate this machine before reading and understanding all the available manuals.
- 2) Do not run this machine without knowing the function of every control key, button, knob, or handle. Ask your supervisor or a qualified instructor for help when needed.
- 3) Protect your eyes. Wear approved safety glasses (with side shields) at all times.
- 4) Allow the machine to cool before reaching into it for any reason. The printer bed, printer surface plate, printed part, extruders/nozzles, and other printer interior components can reach very high temperatures and cause serious burns.
- 5) Don't get caught in moving parts. Before operating this machine remove all jewelry including watches and rings, neckties, and any loose-fitting clothing.
- 6) Keep your hair away from moving parts. Wear adequate safety headgear.
- 7) Protect your feet. Wear safety shoes with oil-resistant, anti-skid soles, and steel toes.
- 8) Take off gloves before you start the machine. Gloves are easily caught in moving parts.
- 9) Remove all tools (wrenches, check keys, etc.) from the machine before you start. Loose items can become dangerous flying projectiles.
- 10) Never operate a 3D printer after consuming alcoholic beverages, or taking strong medication, or while using non-prescription drugs.
- 11) Protect your hands. Stop the printer bed movement and extruder translation mechanism:
 - a. Before opening the printer access door
 - b. Before reaching into the machine for any reason
 - c. Before changing parts
 - d. Before removing the printer bed tray, printed parts, or filament debris
 - e. Before you make an adjustment to the extruder, nozzles or any interior mechanism.
- 12) Protect your eyes and the machine as well. Don't use a compressed air hose to remove the debris or clean the machine.
- 13) Stop and disconnect the machine before you perform maintenance and repair operations.

- 14) Keep work area well lighted. Ask for additional light if needed.
- 15) Do not lean on the machine while it is running.
- 16) Prevent slippage. Keep the work area dry and clean. Remove obstacles of any kind around the machine.
- 17) Avoid getting pinched in places where the printer bed or extruder arm movement can cause a crush or pinch injury
- 18) Do not operate the printer with the printer access door open or any of the windows or service access panels removed.

3 Main Diagnostic Checklist

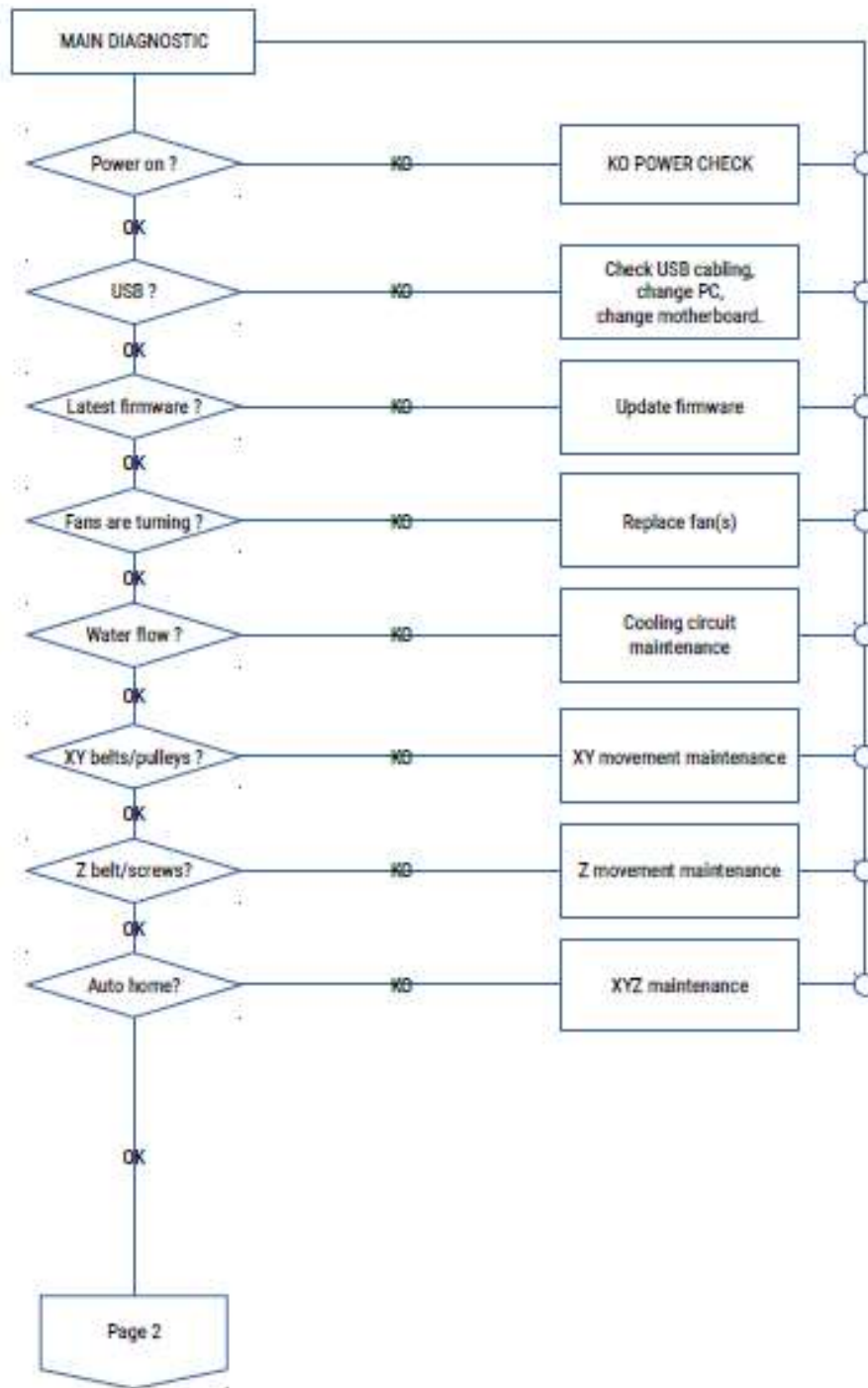

4

Figure 2.1.1 Main Diagnostic Flowchart Page 1

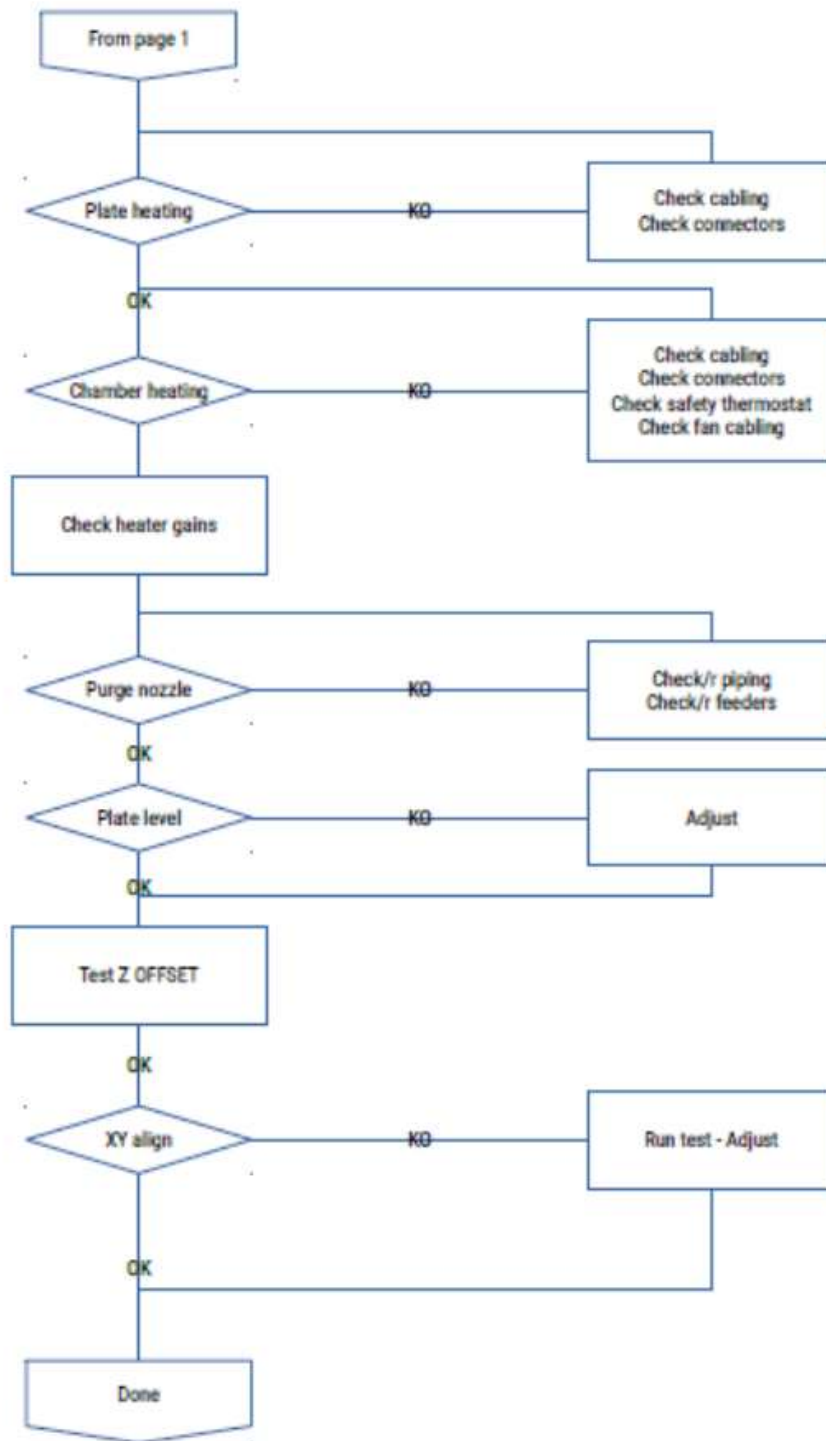

Figure 2.1.2 Main Diagnostic Flowchart Page 2

4 Repair Procedures

CAUTION - Always remove AC power cord before attempting any maintenance on heated chamber / plate or left part (AC power area) of the machine

CAUTION - The procedures are to be performed by trained personnel. If you didn't attend to 3ntr training procedures STOP NOW.

4.1 No Power Diagnostic Flowchart

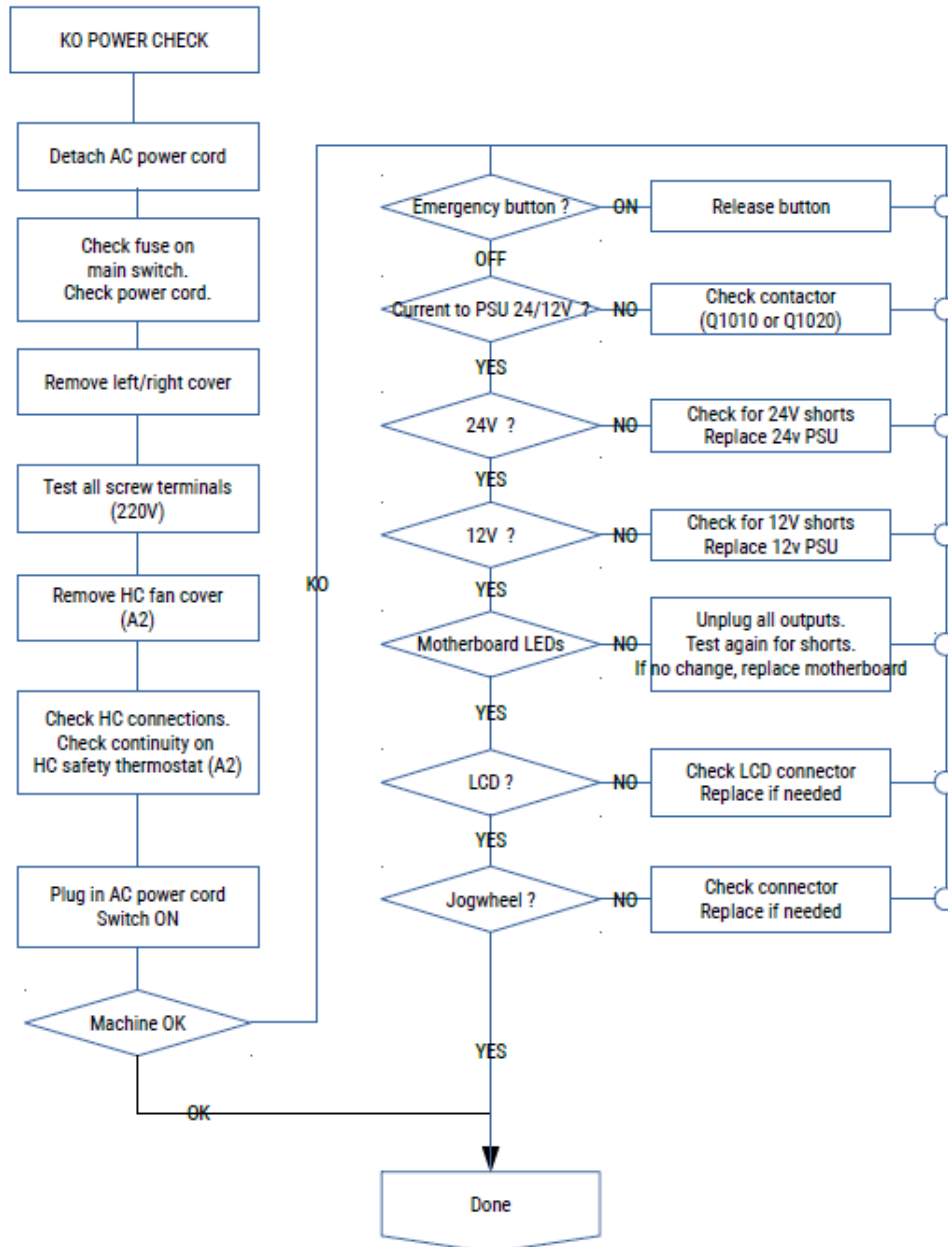

Figure 4.1.1 No Power Diagnostic Flowchart

4.2 No Power Check

Tools needed before undertaking this task:



Figure 4.2.1 Multimeter



Figure 4.2.2 Phillips Screwdriver



Figure 4.2.3 Hex Keys

- 1) Detach AC power cord



Figure 4.2.4 Detach Power Cord

- 2) Check fuse on main switch. USE MULTIMETER TO CHECK.
A good-looking fuse may be tripped anyway.



Figure 4.2.5 Checking Fuse on Main Switch

- 3) Check AC power cord – swap it with another one if possible
- 4) Test all AC screw terminals



Figure 4.2.6 Screw Terminals for Testing

- 5) (A2) Remove HC fan cover



Figure 4.2.7 HC Fan Cover Removed

- 6) (A2) Check HC/FAN connections
- 7) (A2) Disconnect safety thermostat



Figure 4.2.8 Safety Thermostat

- 8) (A2) Using a multimeter, assure that current is passing thru safety thermostat



Figure 4.2.9 Checking Safety Thermostat Current

- 9) Plug in AC power cord. **WARNING** machine is powered on now
CAUTION - KEEP EVERYONE AWAY. Only trained maintenance people can be near the machine



Figure 4.2.10 Plug In Power Cord

- 10) Turn on machine – IF STILL NO POWER, go on with this checklist
11) Check that EMERGENCY button is released



Figure 4.2.11 Release Emergency Button

- 12) Check that current is arriving on PSU AC screw terminals.
- 13) Check that AC tension is present on A1-A2 contactor terminals. If yes, contactor may be defective: replace it. If not, emergency button and /or its cabling could be damaged.

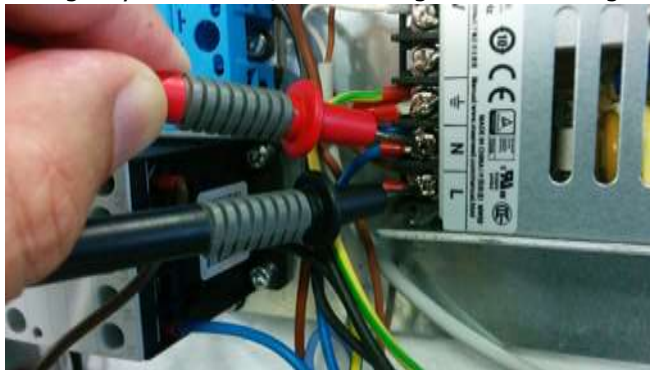

Figure 4.2.12 PSU AC Screw Terminal Current Check

- 14) Check that there is 24Vdc output on 24v PSU. If not, turn power off. Detach all 24V PSU outputs. Power on again. If still no 24V, replace PSU



Figure 4.2.13 Check Output Voltage on PSU

- 15) Check that there is 12Vdc output on 12v PSU. If not, turn power off. Detach all 12V PSU outputs. Power on again. If still no 12V, replace PSU



Figure 4.2.14 Check PSU Output Voltage

16) Is the green LED lit on the motherboard?

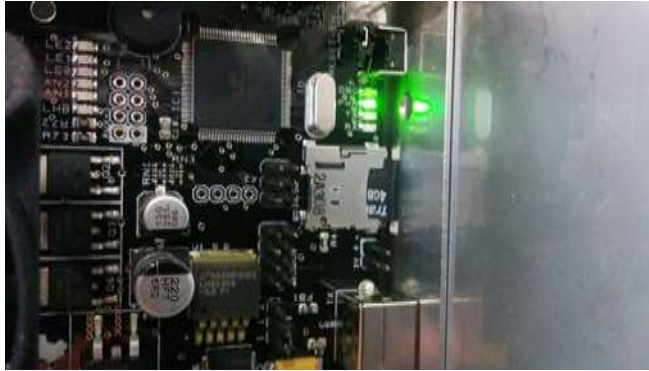

Figure 4.2.15 Green LED on Motherboard

17) If LED is not lit, turn off printer. Check for shorts on Fans and heaters. If shorts are found, remove short. If no shorts are found replace motherboard

18) Is LCD lit? If not check cabling/connection – replace LCD if needed.



Figure 4.2.16 LCD Lit/Printer Ready

19) Is Jogwheel is working? If not check cabling/connection - replace jogwheel if needed.

4.3 Fuse is blown repeatedly

- 1) Check fuse rating: on A4 must be 5A, on A2 must be 15A
- 2) Unplug machine, then check all screw terminals for AC voltage (SSR, PSUs, contactor)
- 3) Check that fuse holder is not ruined – replace it if needed (along with switch body)
- 4) Be sure that machine is using latest firmware (low power consumption)
- 5) If still having issues, be sure that AC power is within tolerance (230V or 110V +/- 5%)

4.4 Mother Board Cabling

Motherboard is the brain of the machine: any problem here will be a problem for the entire machine. Therefore, be sure that motherboard is wired correctly, with no loose connector or any slack cable around.

- 1) Jumpers
Jumpers are needed to set some hardware configurations. Be sure to set jumper position as in the following figure:

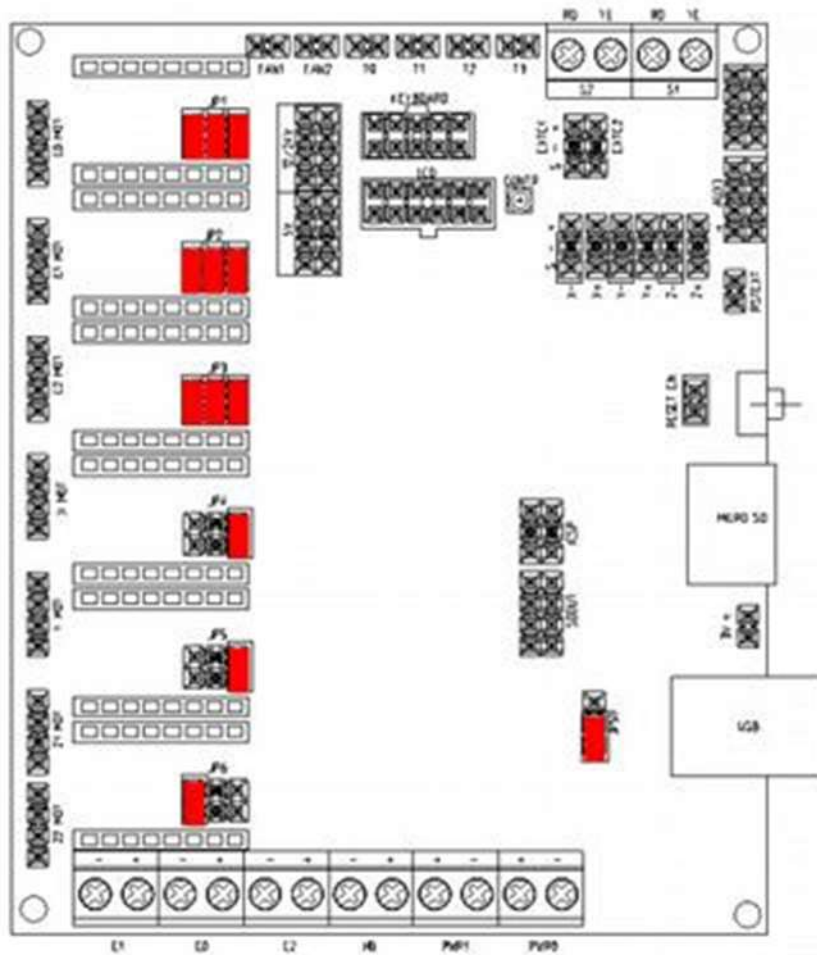

Figure 4.4.1 Motherboard Cabling

2) Drivers

Drivers are the interface between the motherboard and the stepper motors that move XYZ and E axes. Care must be taken to seat them without bending pins and with the correct orientation (trimmer at right) To check current on each driver: put multimeter probes as shown below (black probe on “-” PWR screw, red probe on selected driver trimmer).

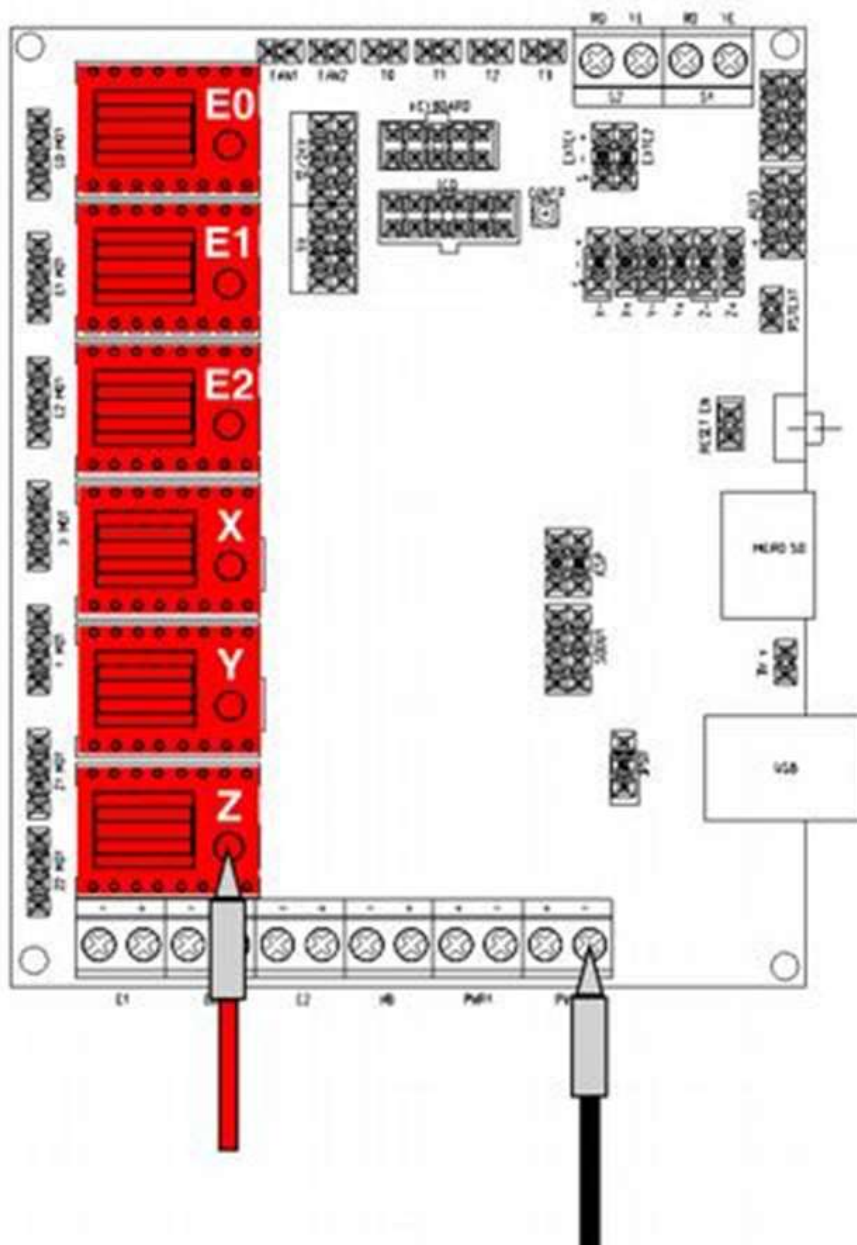

Figure 4.4.2 Drivers

- 3) North and South connections.
 24Vdc connectors are on the lower part of the motherboard.
 Fan/HC output and HB/HC temperature sensors are on the upper edge of the motherboard.

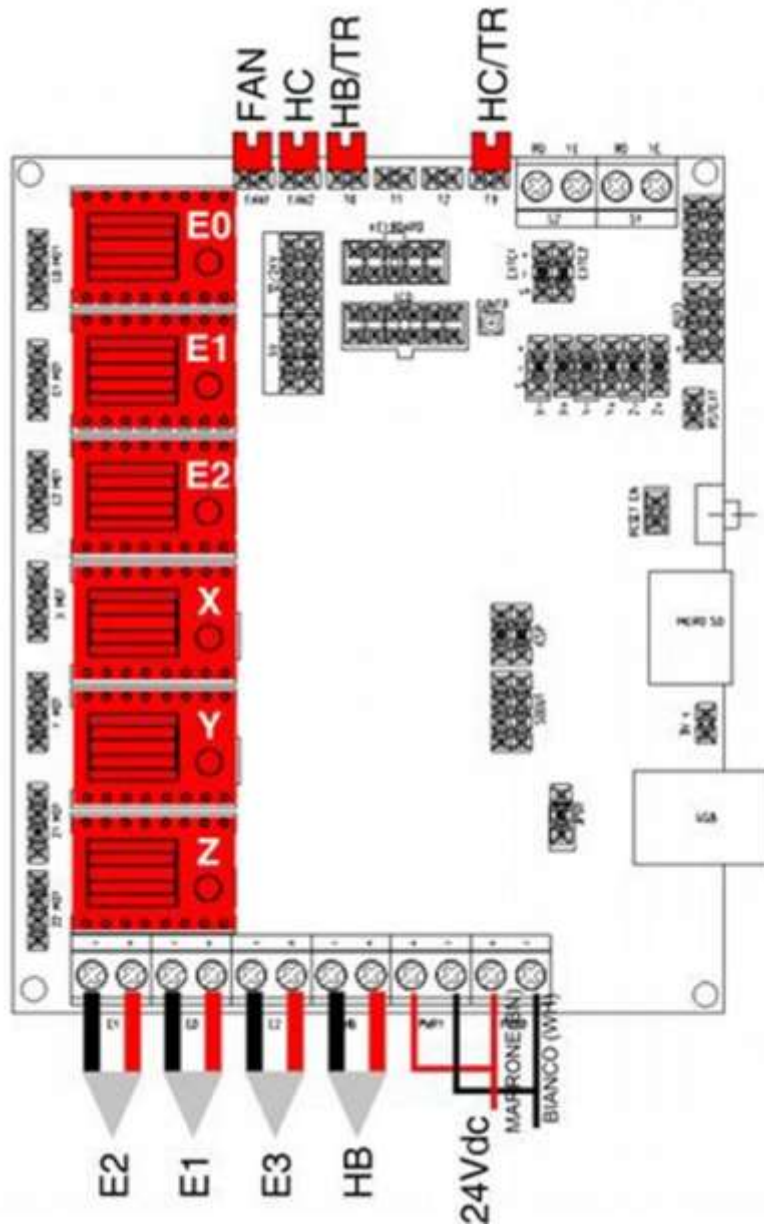

Figure 4.4.3 North/South Connectors

- 4) Thermocouples / servo / filament sensor / LCD / Jogwheel.
 Thermocouples (E1 / E2 / E3) are used to precisely sense the temperature into the extruders. Servo connector is plugged top right (red position for A4, green position for A2). Filament sensor is plugged at the Black/yellow pins aside the servo connector (right for A4, left for A2).

CAUTION - BE ABSOLUTELY SURE NOT TO PLUG filament jumper on the lower pins (red dot near servo connector). Jogwheel connector goes (notch UP) on the ENC connector. LCD goes (notch DOWN) on LCD connector. LCD contrast is set with the trimmer near the LCD socket.

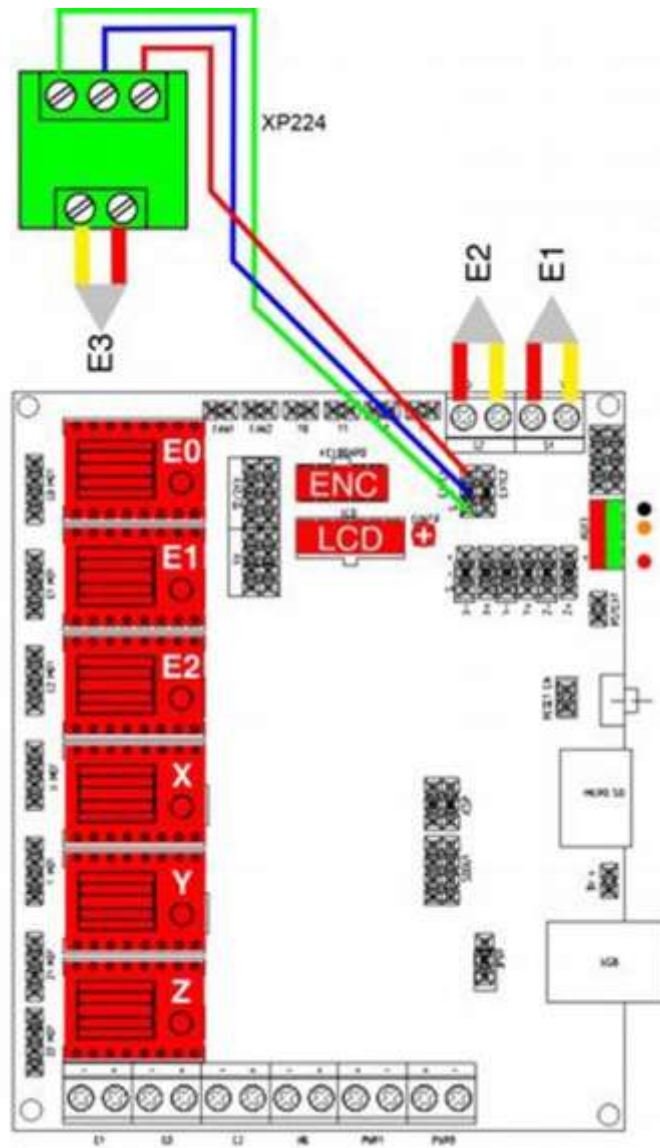

Figure 4.4.4 Thermocouple, servo, encoder, lcd, filament sensor

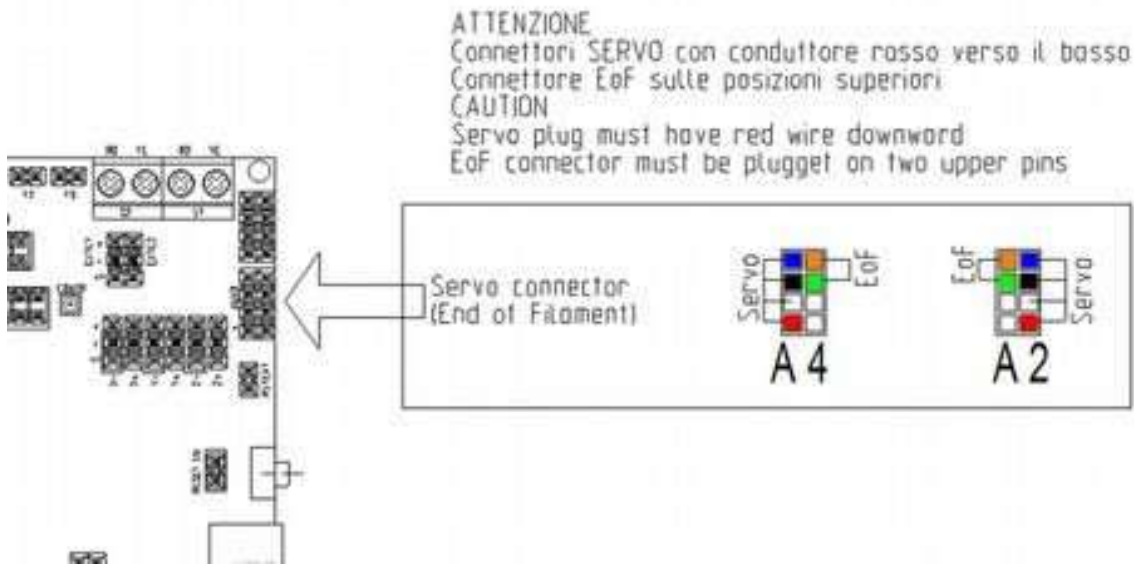

Figure 4.4.5 Servo and End of Filament Connections

5) Fan and Endstops

Fan connection must be ALWAYS with the red lead on connector facing to the right.
 Fan connection socket: be sure to use the upper half of the socket (marked as 12/24V) as from following image. End stop must ALWAYS be connected on the two lower pins of the end stop socket.

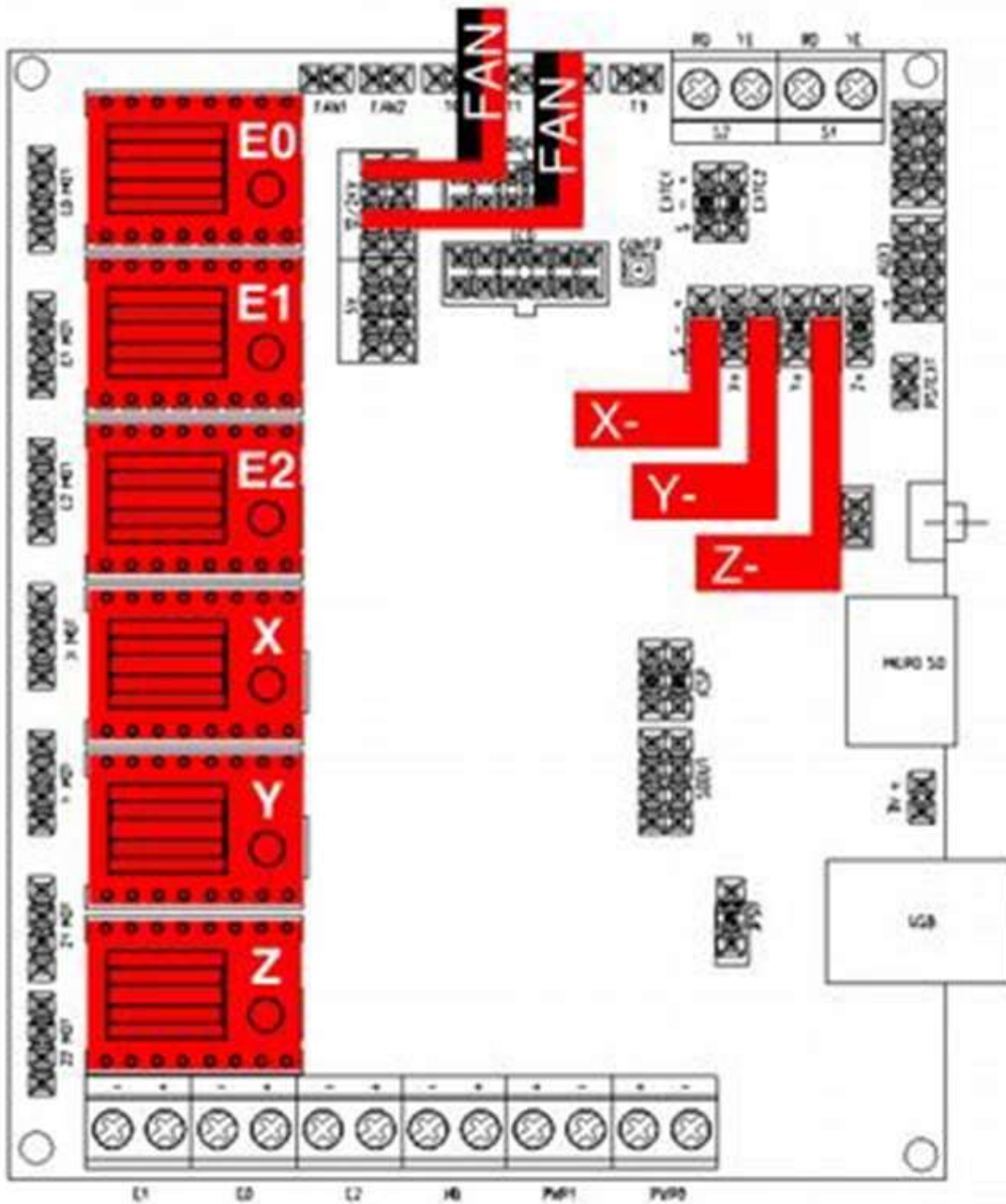

Figure 4.4.6 Fan and Endstops

6) Correct Appearance. If motherboard is correctly wired, it should look like this:

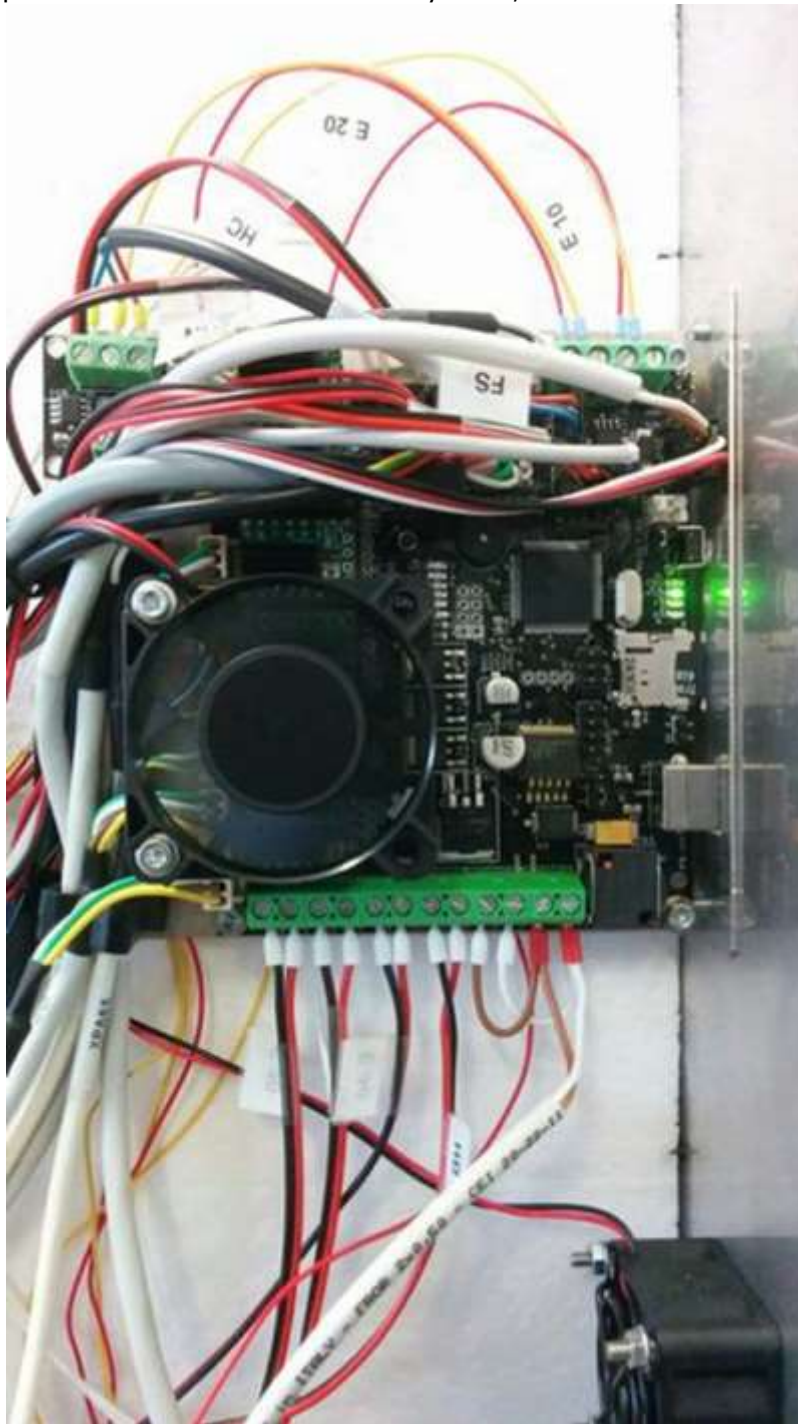

Figure 4.4.7 Properly Cabled and Functioning Motherboard

4.5 Cooling Circuit – Maintenance Flow Chart

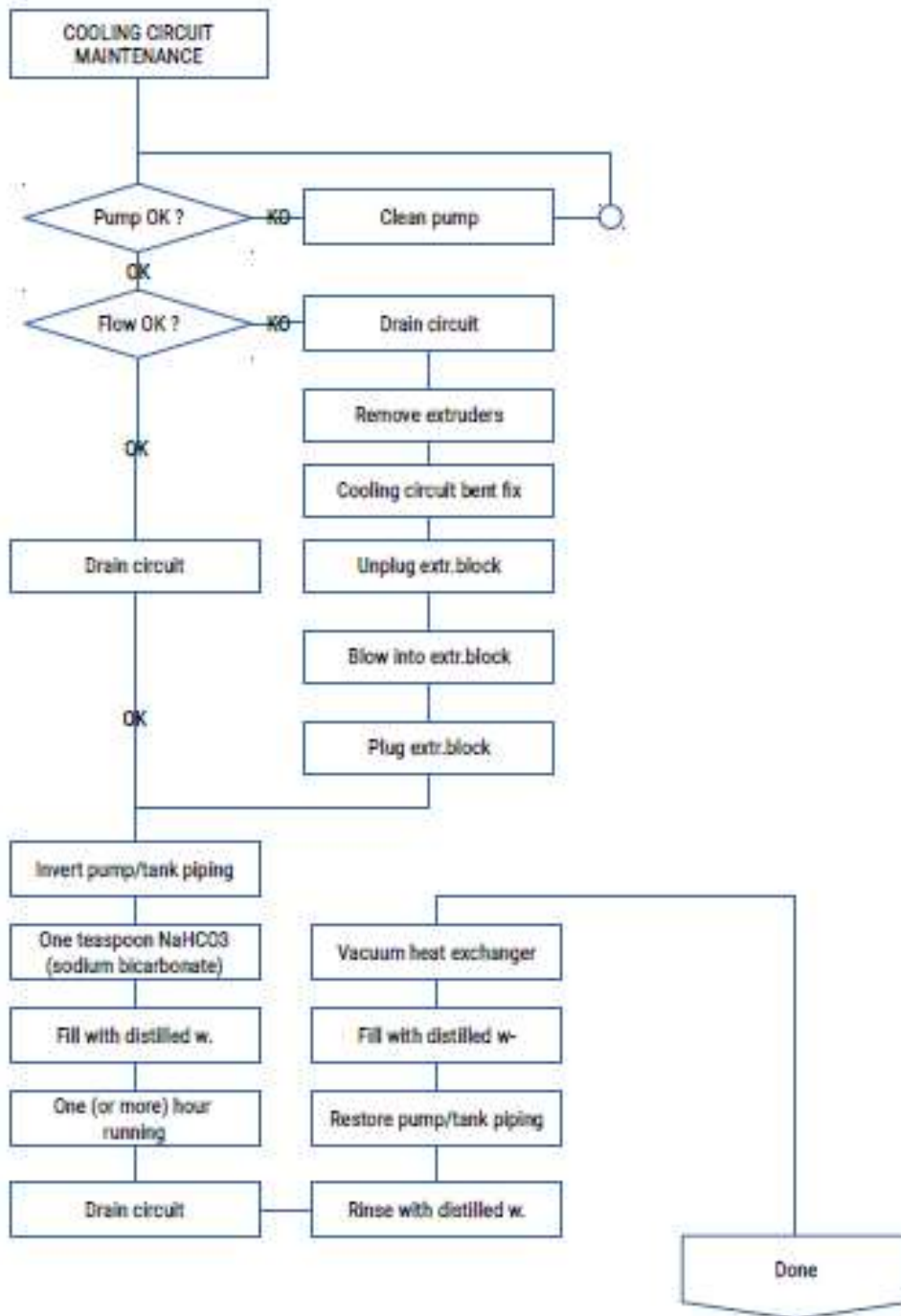

Figure 4.5.1 Cooling Circuit Maintenance Flow Chart

4.6 Cooling Circuit – Drain System

Tools needed before undertaking this task:



Figure 4.6.1 Filling Bottle



Figure 4.6.2 Distilled Water



Figure 4.6.3 Cellulose Rags/Towels



Figure 4.6.4 Empty Containers (Water Bottles Shown)

CAUTION - ALWAYS USE PUREST POSSIBLE DISTILLED WATER. Any other fluid will void warranty

- 1) Turn off printer, unplug power cord



Figure 4.6.5 Unplug Power Cord

- 2) Gain access to the pump/reservoir assembly
- 3) Using the filling bottle, remove as much liquid you can from the reservoir
- 4) Unplug the inlet pipe to the reservoir

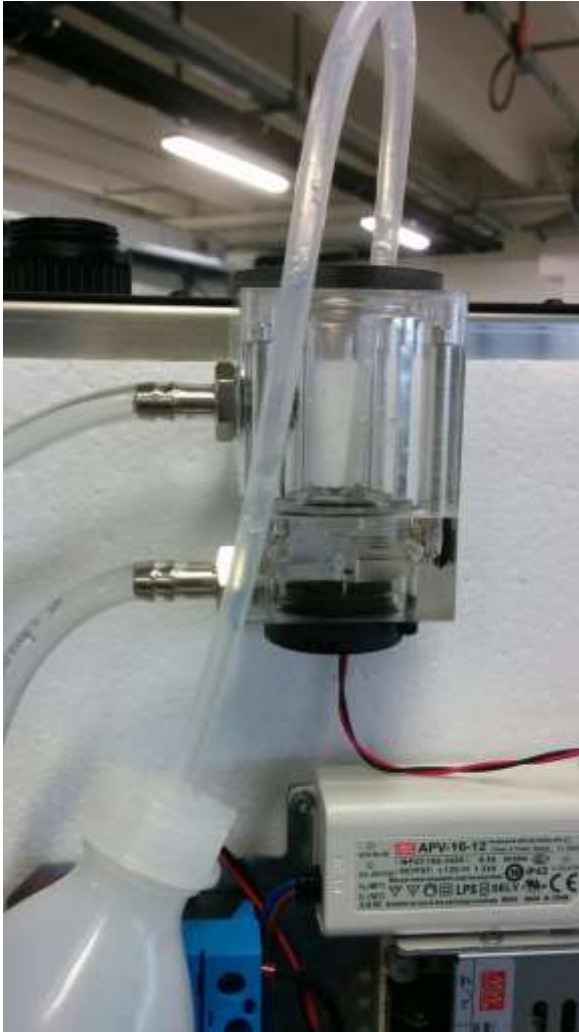

Figure 4.6.6 Removing Liquid from Reservoir



Figure 4.6.7 Unplug Inlet Pipe

- 5) Drain any liquid left in the circuit



Figure 4.6.8 Drain Remaining Liquid

- 6) Put some rags below the pump area



Figure 4.6.9 Rags Below Reservoir

- 7) Detach the outlet pipe
- 8) Put inlet pipe into a container to collect fluid during blowing



Figure 4.6.10 Detach Outlet Pipe

- 9) Blow (gently) with compressed air into outlet pipe. This way you will be able to drain any remains of liquid into the circuit



Figure 4.6.11 Blowing Compressed Air into Outlet Pipe

- 10) Machine ready!

4.7 Cooling Circuit – Fix Bent Piping

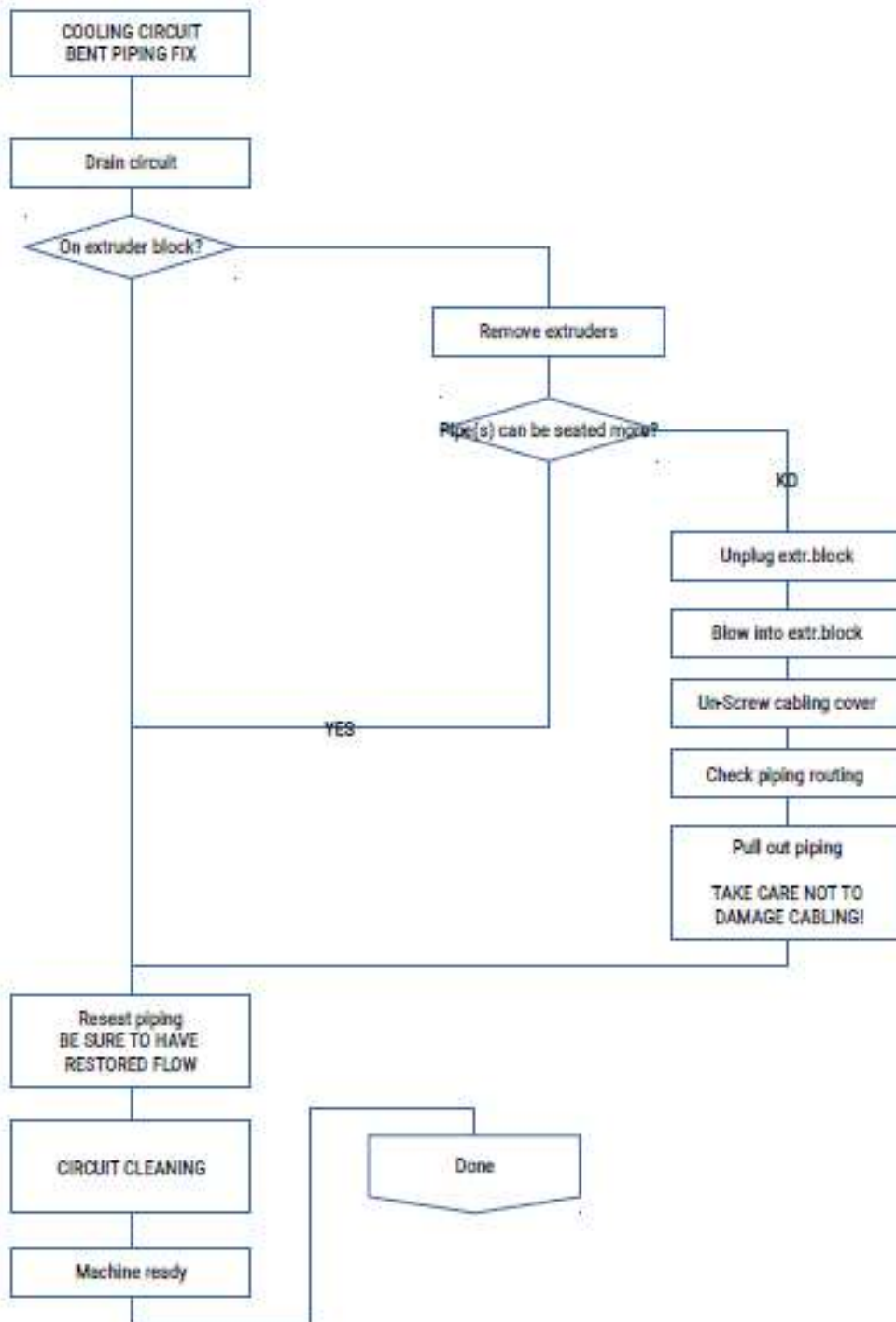

Figure 4.7.1 Cooling Circuit Bent Piping Diagnostic Flowchart

Tools needed before undertaking this task:



Figure 4.7.2 Compressed Air Gun



Figure 4.7.3 Hex Keys

Bent circuit piping prevents correct flow of water cooling: correct flow must be restored to regain complete control of extrusion process.

If bend is happening anywhere in the printer BUT NOT at the extruder block:

- 1) Remove bend, re-seat piping
- 2) Test water flow
- 3) Clean cooling circuit

If bend is happening at the extruder block (WE ASSUME THAT MACHINE IS FULLY DRAINED):

- 1) Remove extruders
- 2) Detach piping (if pipes were fully seated, they will need to be shortened later on)



Figure 4.7.4 Top View of Extruders

- 3) Blow inside extruder block water inlet/outlet (keep some towel upon block to avoid spreading water around)
- 4) If pipes were fully seated, shorten 5mm
- 5) Put back piping – see if there is any visual “knee” that could still prevent free flow of coolant.



Figure 4.7.5 Coolant Piping after Replacement

- 6) You may need to pull some piping
- 7) Clean cooling circuit

4.8 Cooling Circuit - Cleaning

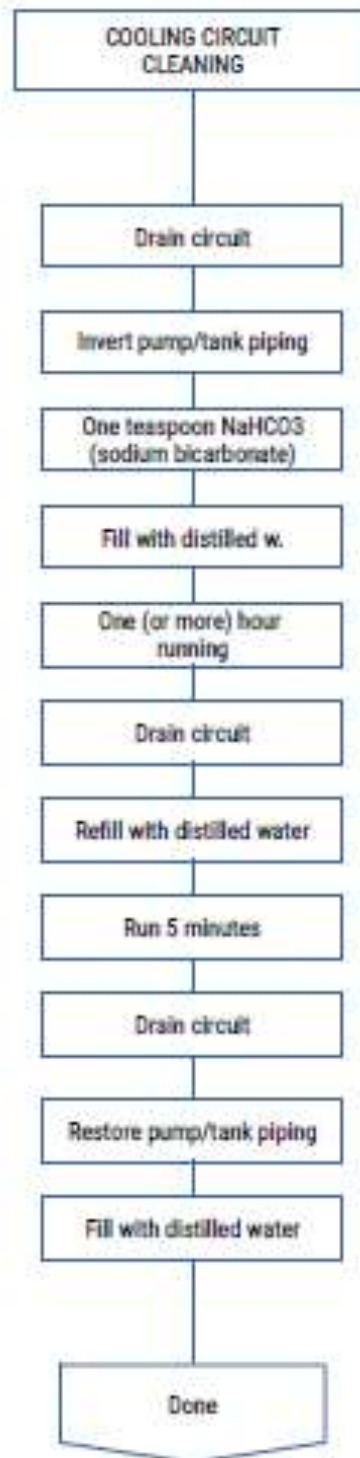

Figure 4.8.1 Cooling Circuit Cleaning Flowchart

Tools needed before undertaking this task:



Figure 4.8.2 Filling Bottle



Figure 4.8.3 Distilled Water



Figure 4.8.4 Empty Containers

CAUTION - ALWAYS USE PUREST POSSIBLE DISTILLED WATER. Any other fluid will void warranty



Figure 4.8.5 Cellulose Rags/Towels



Figure 4.8.6 Baking Soda (Sodium Bicarbonate)

- 1) Power OFF and Unplug Printer



Figure 4.8.7 Unplug Printer

- 2) Completely drain machine
- 3) Invert inlet with outlet on pump/reservoir



Figure 4.8.8 Invert Inlet & Outlet on Pump/Reservoir

- 4) Put one teaspoon baking soda into reservoir
- 5) Fill reservoir with distilled water
- 6) Turn on machine
- 7) Don't let the level go too low on reservoir. Use emergency button to stop.
- 8) Once water level is steady on reservoir, let it run for 1-2 h
- 9) Completely drain machine
- 10) Refill with distilled water
- 11) Run for 5 minutes
- 12) Completely drain machine
- 13) Revert piping (inlet outlet) on pump/reservoir to original configuration.
- 14) Refill with printer cooling fluid (the red one)

4.9 Cooling Circuit – Pump Cleaning

This task is needed when pump is not turning (or it is turning at low speed)

Tools needed before undertaking this task: (other than the ones needed to drain machine)



Figure 4.9.1 Hex Keys



Figure 4.9.2 Cellulose Rags/Towels

- 1) Turn Printer OFF and remove AC Power.



Figure 4.9.3 Remove AC Power

- 2) Drain cooling circuit. Be sure to have completely drained the pump/reservoir.

- 3) Put some rags below the pump/reservoir.



Figure 4.9.4 Place Rags below Pump/Reservoir

- 4) Remove the screws holding the pump against reservoir. As soon as screws are removed, use rags to absorb all water into pump housing.



Figure 4.9.5 Removing Pump/Reservoir Screws

- 5) Check for:
- gasket /seal integrity
 - foreign part(s) on the pump impeller
 - clean pump shaft



Figure 4.9.6 Inspect Pump Components

- 6) Be sure that impeller is free to rotate on shaft
- 7) Clean the pump seal and the seal "landing zone" on reservoir- (on some pump version the white pin is not present)



Figure 4.9.7 Clean Pump Sealing Surfaces

- 8) Mount pump. Don't tighten screws
- 9) Turn on machine (DON'T refill circuit yet)
- 10) Tighten (gently) the pump screws until are tightened or pump stops running. In any case, never overtighten.



Figure 4.9.8 Refilling Reservoir

- 11) If pump is running, refill circuit and look for leaks. If pump is not running, check connection. Replace if connection is ok.

4.10 Pulleys

It may happen that pulleys are getting loose or moving along the bearings, getting to touch supporting metal sheet. To check that pulleys are running OK:

- 1) Turn OFF machine, remove USB cable.
- 2) Grab extruder hold assembly and move it left/right and back/forth. You must feel continuous friction, without any discontinuity.
- 3) Turn ON machine (to get LED lighting) and check pulleys clearance – you must be able to take a thin paper fragment between pulley and the supporting metal.

NOTE - XY motors are strong enough to cope with some pulley friction.



Figure 4.10.1 Pulleys

CAUTION - Moving the extruder holder around by hand may generate enough current to fry any USB device connected to the printer – be sure to unplug printer before attempting ANY manual movement.

4.11 Heat Exchanger Cleaning

Even in case of setting, it's quite common to get airflow blocked by dust/hair/fibers that may bring serious trouble if routine cleaning is not performed.

Use a vacuum cleaner to remove any contaminant from heat exchanger inlet: NEVER blow air or compressed air onto heat exchanger surface from outside to inside – you may worsen situation blowing contaminants INSIDE the printer. You can do the opposite, blowing thru the radiator from inside the printer.

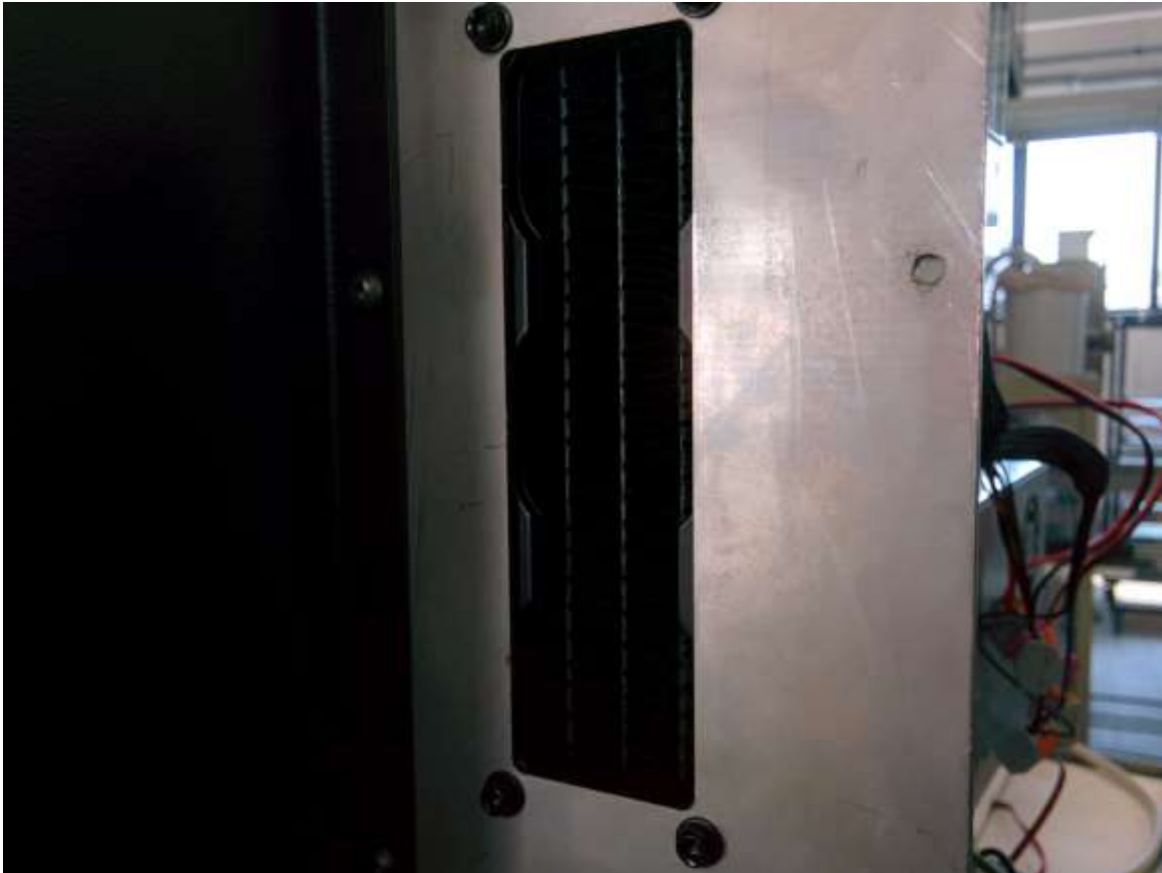

Figure 4.11.1 Heat Exchanger

4.12 Stepper Heat Sinks – Cleaning

This is one of the printer areas most subject to dust accumulation.

NOTE - Clean this area with compressed air can. DON'T use industrial compressed air guns!



Figure 4.12.1 Stepper Heat Sinks

4.13 Belt Tension

Upper and lower belts should have same tension. If you can feel notable difference, then you must correct situation.

Loosen the nuts of the plate holding the X or Y motor – push (or pull it, if you removed the right cover) until you get even tension among both X and Y.

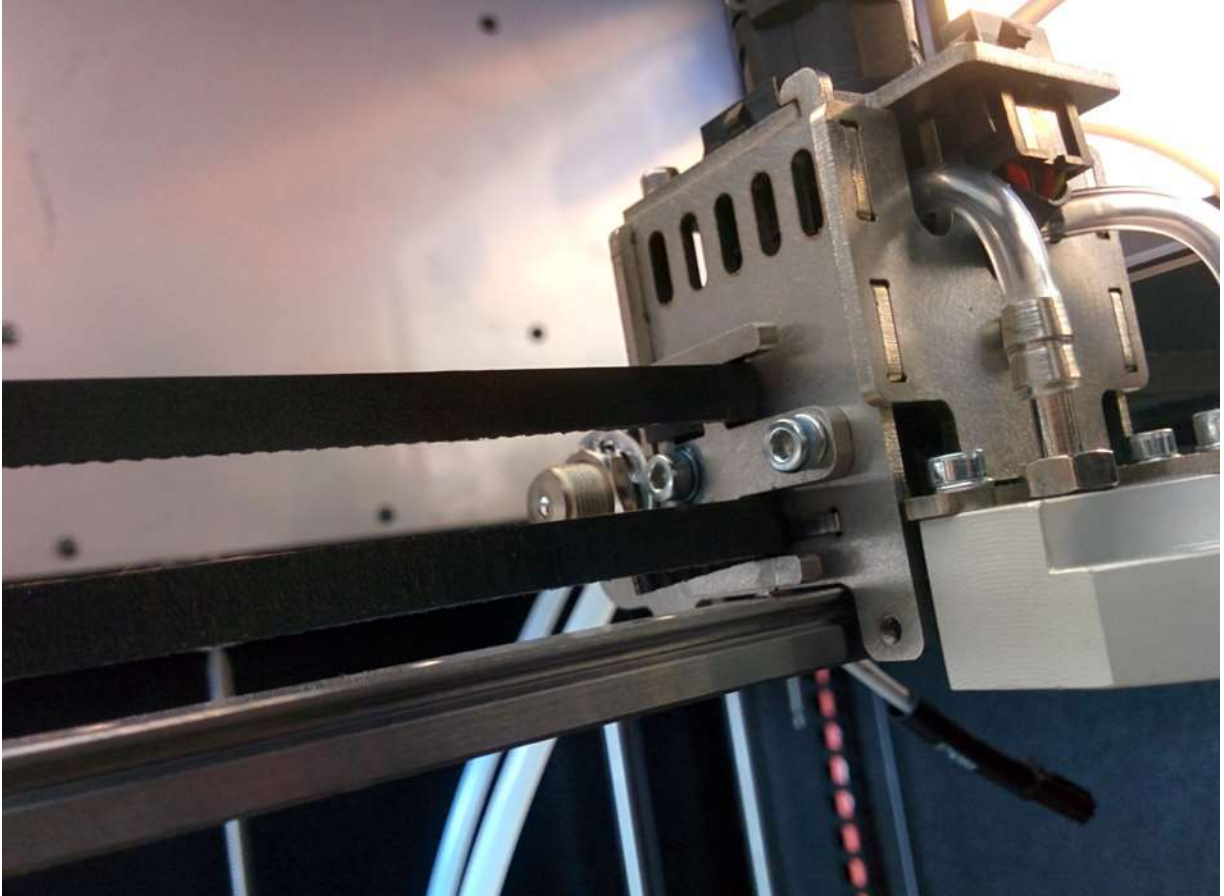

Figure 4.13.1 Belts – Check Tension

4.14 Heated Chamber Diagnostic Flowchart

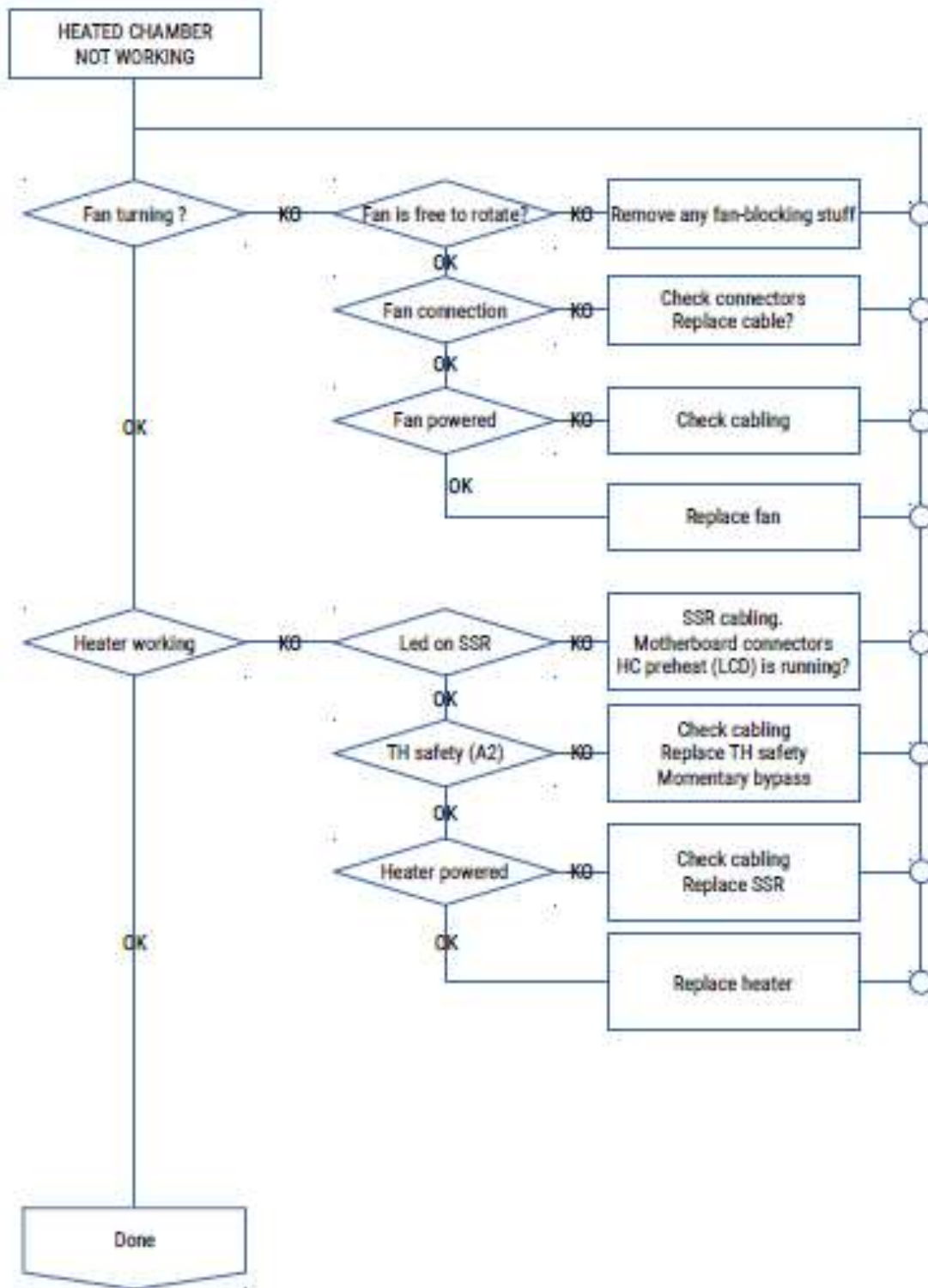

Figure 4.14.1 Fan Inlet

4.15 Heated Chamber Inspect & Repair

See Heated Chamber Diagnostic Flowchart Section 4.12 for troubleshooting guidance.

CAUTION - Failing to disconnect AC cord may expose to electric shock risk – DON'T run into any risk, ALWAYS FULLY DISCONNECT AC POWER WHEN SERVICING ANY AC DEVICE!!!! THESE PROCEDURE(S) are for trained electrical maintenance technicians: DON'T attempt if you lack proper training, tools and safety equipment. SEEK QUALIFIED HELP +or+ revert to 3ntr support before attempting ANY activity on LIVE AC powered parts.

Fan is free to rotate:

- no debris inside fan housing
- no plastic "hairs" around
- turning fan by hand will get fan rotating alone for few seconds



Figure 4.15.1 Fan Inlet

Fan connection:

- Remove back HC cover (on A2)
- Remove back panel (on A4)
- All the connectors are securely engaged (A2)
- All screw terminals are securely tightened (A4)
- Pull gently to assess engagement
- Fully push inside to get seated connectors



Figure 4.15.2 Fan Connections (Cover Removed)



Figure 4.15.3 LED on Heated Chamber SSR

TH safety:

- check that connection is OK
- check TH is working (at room temperature, unplug both connectors entering the TH and using a multimeter you must read continuity)
- bypass the TH (detach the wire going from TH to the heater – plug the other one entering the TH directly to the heater)



Figure 4.15.4 TH Connections

SSR cabling: CORRECT CABLING (screw terminal holding just the metal tip of the lead)
NOTE - ALL leads entering the SSR must be checked



Figure 4.15.5 Correct SSR Cabling Connection

SSR cabling: WRONG CABLING (screw terminal holding the plastic part of the lead)



Figure 4.15.6 Incorrect SSR Cabling Connection

Heater Powered:

- Check that there is current arriving on the heater poles (fed by brown and blue leads in picture)
- If power is present on heater poles and still no heating, then replace heater.



Figure 4.15.7 Heater – Power and Current Checks

4.16 Screw Terminals - Tighten

Vibrations, extreme temperatures may loosen the screw terminals. This can lead to hard-to-diagnose problems: if you happen to get some weird problems hard to explain:

- 1) Turn OFF machine and unplug cord from AC socket
- 2) Remove relevant covers
- 3) Check screw terminals (with a fat tip screwdriver) being tightened correctly. Don't over tighten!

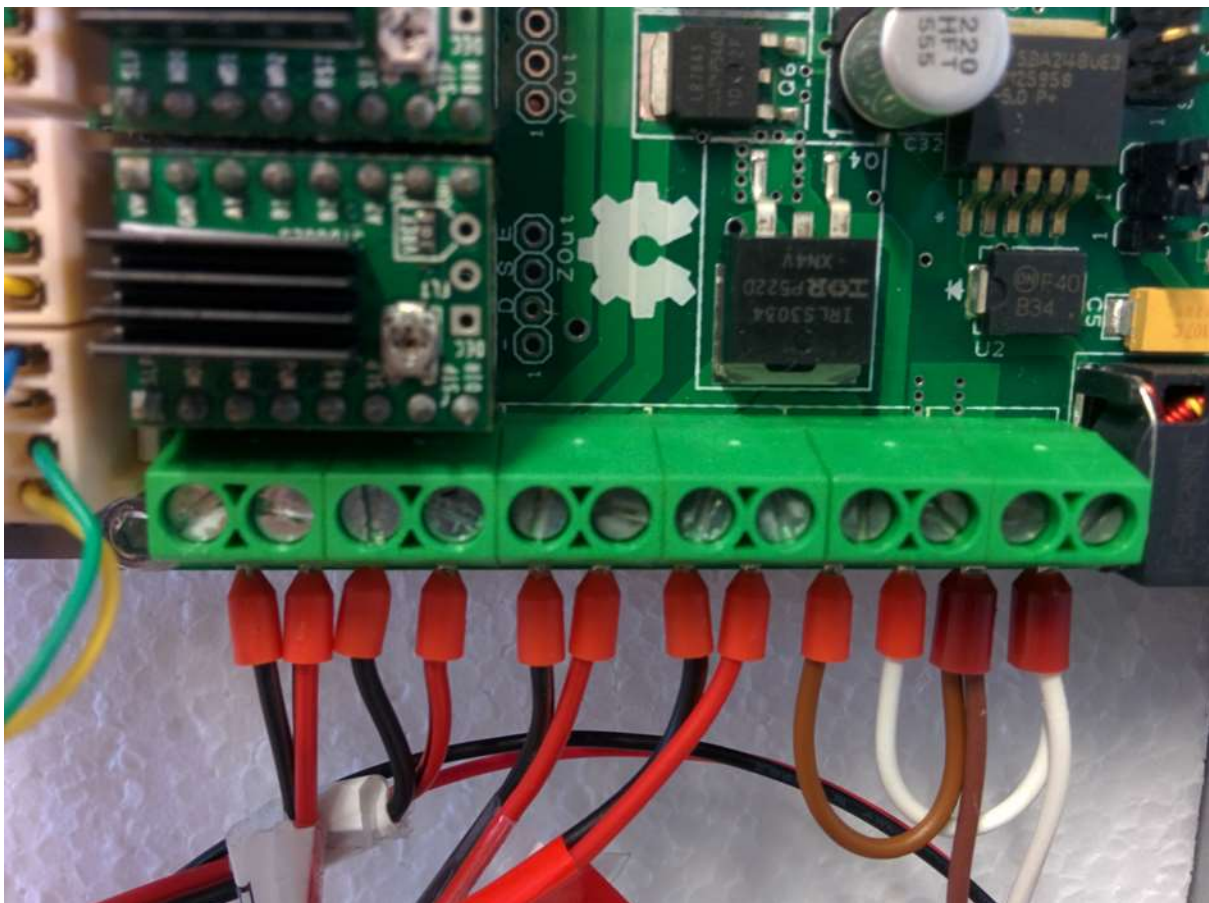

Figure 4.16.1 Screw Terminals – Inspect Tightness

4.17 DC Fans – Inspect

Any DC fan (the small black fans you see on heat exchanger/motherboard area/extruders) must always be running at 100% efficiency. Failing to comply with this requirement the printer may slowly fade into overheating or even more difficult problems to diagnose.

Therefore:

- Keep fans clear from cables or anything that can prevent fan rotation
- If fan is showing slow/irregular rotation immediately replace it.

Sunon fans have proved so far exceptionally reliable – usually the connections are to be blamed for malfunction, not the fan itself. Check that connection is working ok. In case of 1st gen printers (no Sunon fans) you may eventually want to replace with more reliable/newer parts.

IMPORTANT - Motherboard fan must be blowing TOWARD the motherboard (see pic)

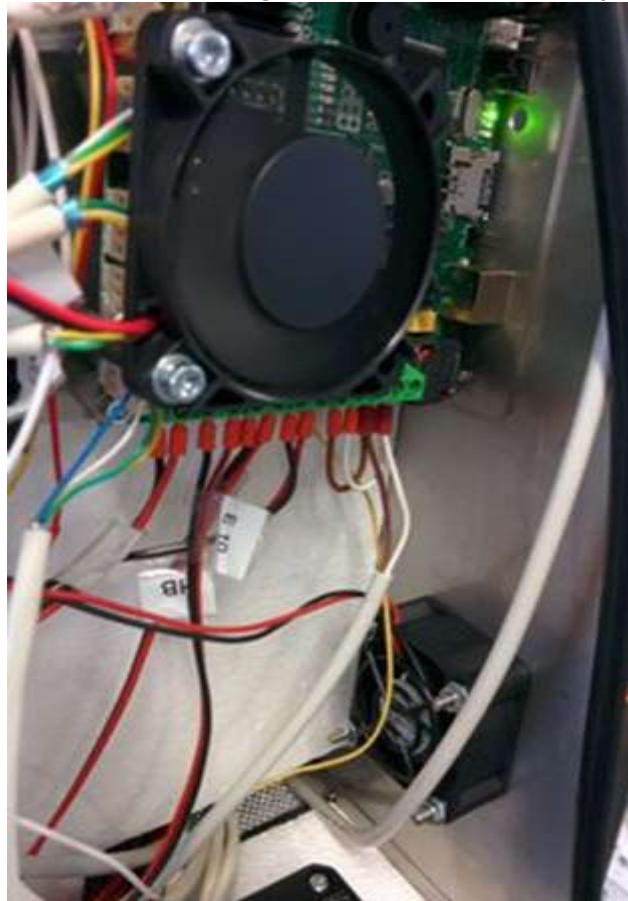

Figure 4.17.1 Motherboard Fan Working Correctly (Green LED)

4.18 Extruder Gain – How to Find

The cornerstone of a good printing is control of temperature. Since 2016, all machines are delivered with calibrated heaters. If you can't tell the serial number of your heater(s) you can still compute the gain by yourself with this procedure:

- 1) Remove front panel to reach upper extruder area (tube adapters)
- 2) Move Z at 50
- 3) Bring extruders at middle, front area
- 4) Remove filament from selected extruder
- 5) Remove PTFE piping
- 6) Set gain to 1. Save configuration, using LCD functions.
- 7) Using Repetier Host (PC USB connection) or any browser (if you are using the print server option) set the desired extruder to 240° C
- 8) Manually feed some ABS filament and be sure to see some filament being extruded out of the nozzle
- 9) Remove filament, put the temperature probe fully down into the extruder
- 10) Let temperature to settle for one minute, then read the temperature on probe display
- 11) Gain value (n) is obtained with following formula:
 $T_s = \text{set temperature (240}^\circ\text{C)}$
 $T_r = \text{temperature probe readout (I.e.: 232}^\circ\text{C)}$
 $n = T_r / T_s = 232 / 240 = 0,96$
- 12) Set gain of selected extruder and save it using LCD function.

CAUTION - Use ONLY the probes and display supplied from 3ntr to avoid any malfunction

4.19 DC Power Supply Test

Power supply is delivered to be feeding power at 24Vdc +/- 0.3V: you can test it with a multimeter on (+) and (-) poles of the power supply or on motherboard screw terminals. (as shown). Should you get out-of-tolerance reading, you can adjust it with the trimmer on power supply.

NOTE -This is a VERY RARE condition and you must report if you experience this – chances are your power supply is defective: perform repeat measurements during a few hours to assess part sanity.

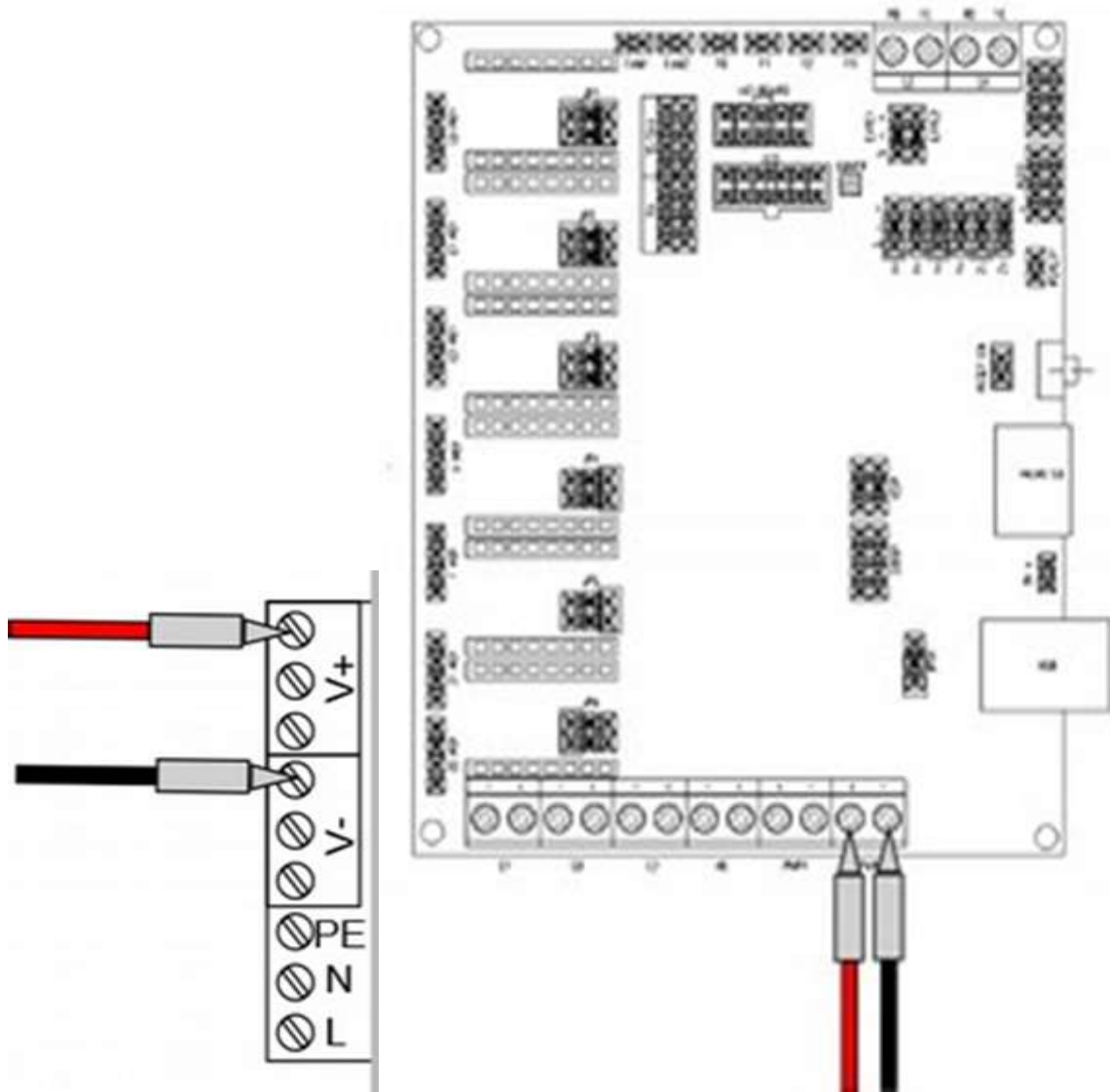

Figure 4.19.1 Motherboard and Power Supply Probe Test Locations

4.20 Stepper Current Setting (OLD Stepper Drivers)

Set multimeter on Vcc:

- Remove fan blowing on the motherboard to gain fully access to stepper drivers
- Black probe on extreme right PWR screw terminal (-)
- Red probe on driver trimmer (small screw-like metal device on top of stepper drivers)
- Readout on E0/E1/E2 = 0.45 V
- Readout on X / Y = 0.75V
- Readout on Z = 1.15V
- Put back the fan
- Check that all connectors are correctly and safely seated

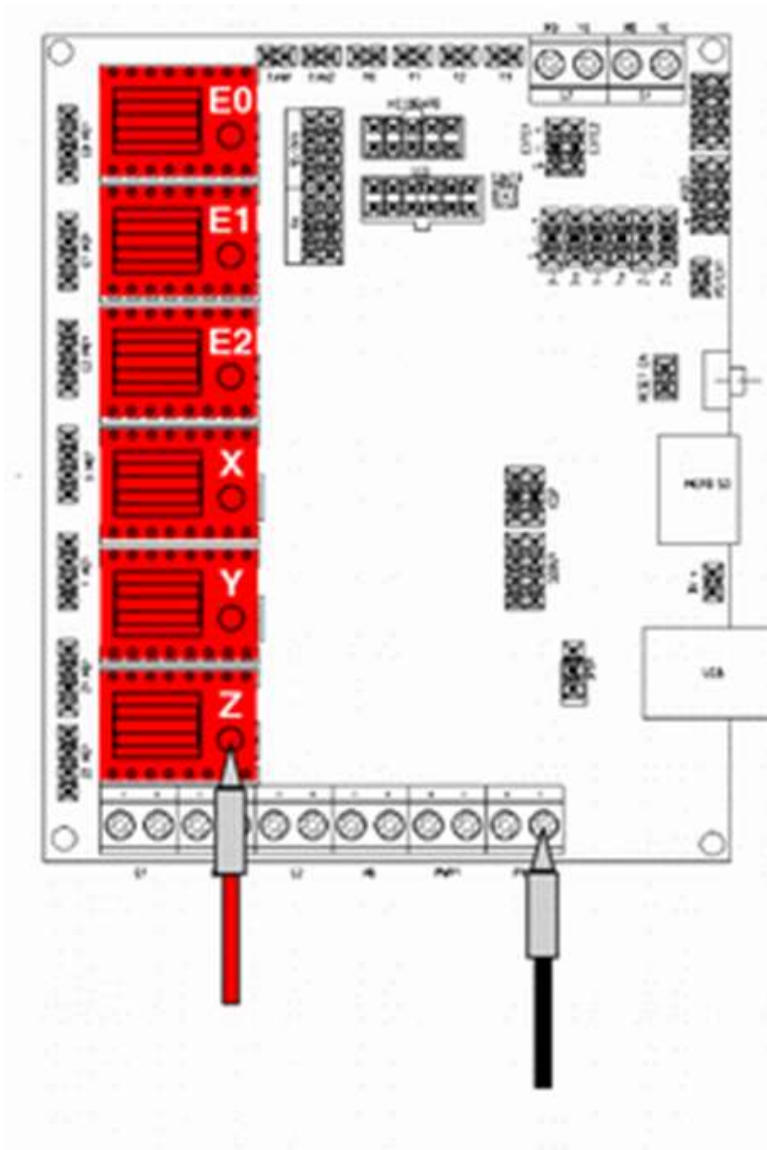

Figure 4.20.1 Multimeter Probe Placement

4.21 Stepper Current Settings (Silent Drivers)

Notice that jumper settings have changed (all removed except Z – see below). Procedure is as for old stepper drivers, values are changed as follow:

- Readout on E0/E1/E2 = 0.9 V
- Readout on X/Y = 1.4 V
- Readout on Z = 1.15 V

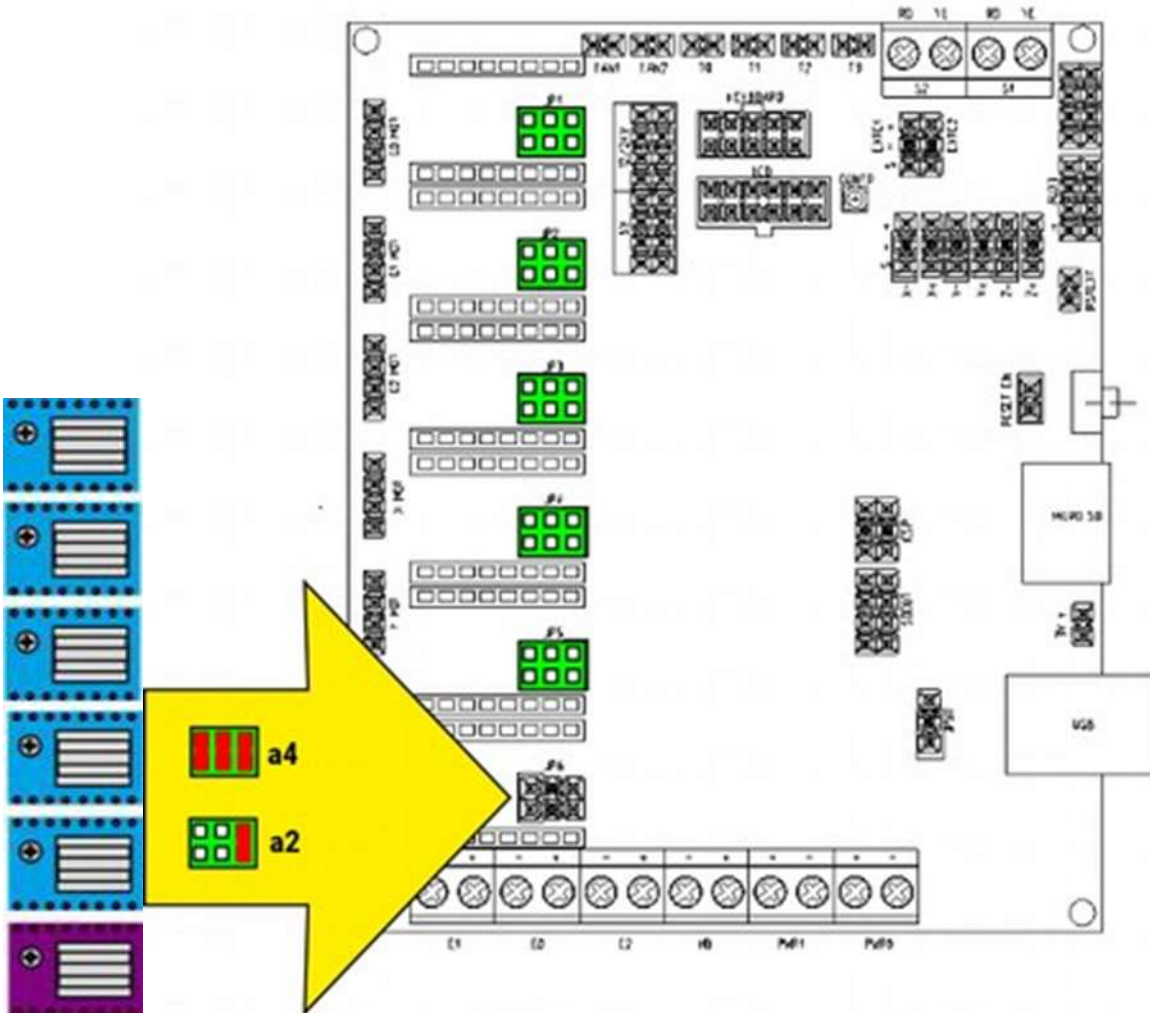

Figure 4.21.1 Silent Driver Jumper Settings

4.22 Stepper Driver Replacement

In case of faulty driver, you can easily replace it following this procedure:

- 1) Turn off power, be sure to remove cord from wall outlet
- 2) Remove right part machine cover, to gain access to motherboard area
- 3) Touch any bare metal part to discharge any static charge that could damage machine electronics
- 4) Remove the faulty driver – just grab it with your fingers. For X-Y-Z driver you must temporarily remove cooling fan.
- 5) Mount the new driver: be sure to have ALL PINS correctly seated and driver is following same orientation of the other ones.
- 6) Put back on the cooling fan.
- 7) Check that cabling and connector is OK.
- 8) Power up machine, test if relevant axis is moving OK.



Figure 4.22.1 Stepper Driver Identification

4.23 Feed Pressure – Check/Restore to Factory Default

Feed pressure is factory set and should never be changed.

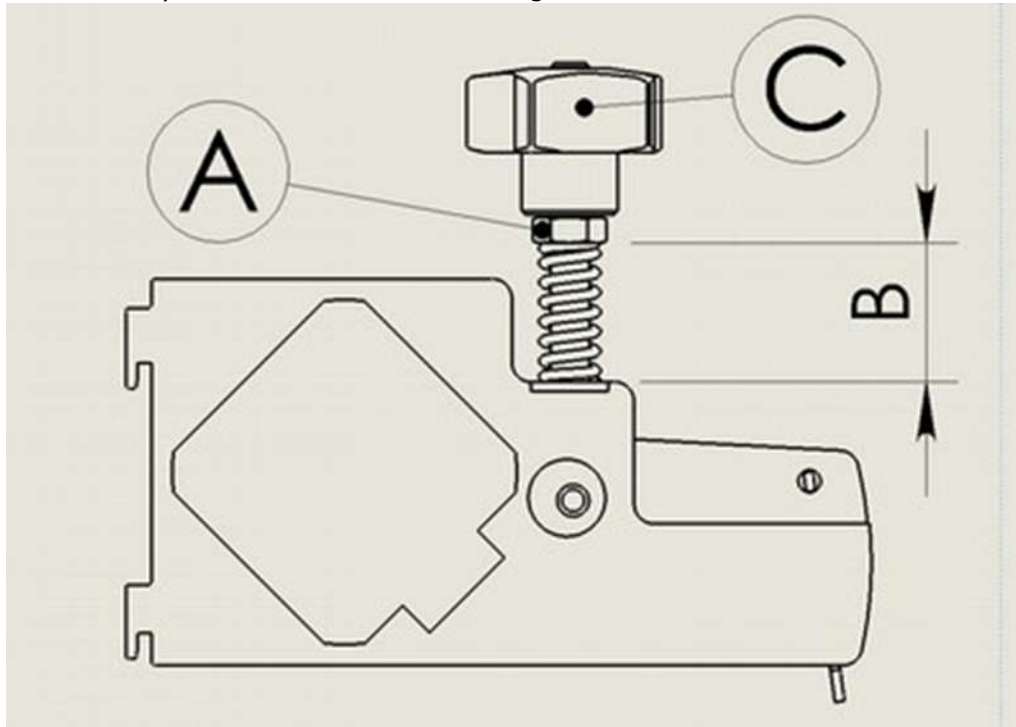

Figure 4.23.1 Feed Pressure Adjustment Diagram

If you need to restore factory setting:

- 1) Release nut "A" with a 10mm spanner, holding "C" wheel.
- 2) Lock feeder into OPEN position, locking it into position as from above pic. 6.

NOTE - For older machines the position could be slightly different. Proof of good setting can be seen during printing process, when machine is repeatedly feeding and retracting – the lever shouldn't move – if you can see some fluctuation then the feeding roller is "chewing" the filament (showing that either pressure is too high, or filament is too soft).

4.24 LCD Display Malfunction – Weird Character Display

Several possibilities:

- LCD overheats due to poor airflow or missing insulation on the back panel.
- Check that all fans (heat exchanger and motherboard extraction) are working.
- Heat exchanger is clean, and air is correctly flowing
- Air can flow freely behind LCD
- Defective LCD – replace it
- Defective motherboard – replace it

4.25 Z Motor Replacement

CAUTION - Power OFF Printer, Unplug, and remove AC cord. BE ABSOLUTELY SURE THAT BY NO MEANS THERE IS AC POWER ARRIVING TO THE MACHINE

- 1) Remove front, left or right cover (depending on the stepper to be removed)
- 2) Unplug Z motor
- 3) Release all the screws from coupling between motor and Z screw. The coupling must disengage from Z screw during removal
- 4) Remove screws holding gearbox against machine chassis
- 5) If working on left side, you may want to remove the upper and right screws holding the electronics plate (letting you rotate it CCW) to get more space to lift and remove motor and gearbox assembly
- 6) Lift and remove gearbox
- 7) Note the distance between coupling and gearbox – you must maintain coupling on the new motor-gearbox assembly at the same distance
- 8) Mount the new gearbox/assembly on the machine
- 9) Push on the heated plate to be sure that it is fully seated on bottom bearings
- 10) Carefully tighten the screws holding the gearbox against machine chassis
- 11) Tighten coupling screws
- 12) Put electrical plate back into original position (if you moved it)
- 13) Plug electrical signal cable into gearbox
- 14) Turn on machine (BE CAREFUL NOT TO REACH live AC cabling area)
- 15) Move up and down (using LCD commands) the Z axis to test

4.26 Heated Chamber – A4 Printer Heater Replacement

CAUTION - Power Down Printer, unplug machine and remove AC cord, BE ABSOLUTELY SURE THAT BY NO MEANS THERE IS AC POWER ARRIVING TO THE MACHINE.

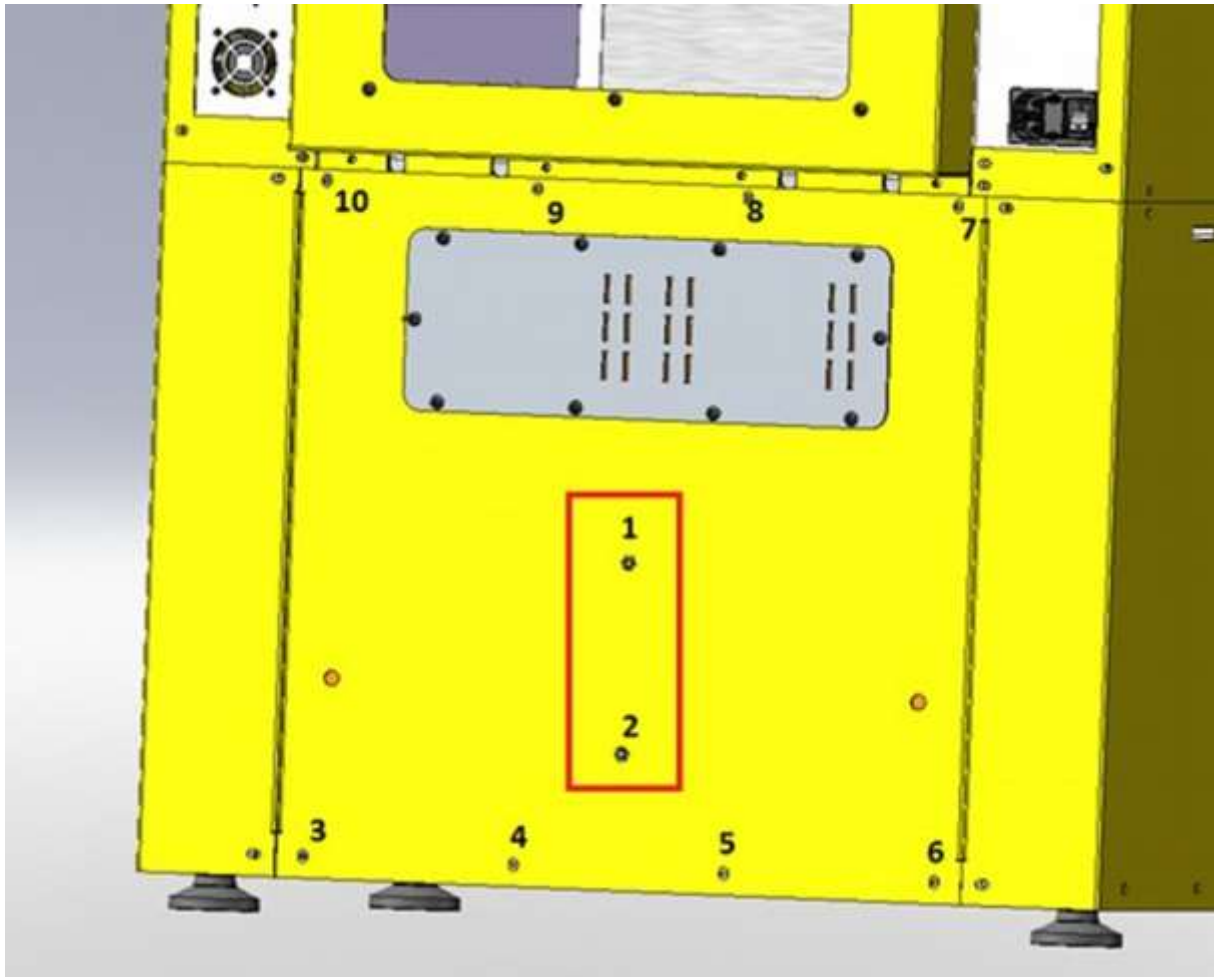

Figure 4.26.1 Printer Rear Cover

- 1) Remove nuts 1-2 with an 8mm spanner
- 2) Remove screws 3-10 with a 2.5 mm hex key
- 3) Slowly open the rear cover, grab the heater/fan assembly from the inside (ask for help at this stage – if the fan/heater assembly falls on the printer bottom it may ruin the foam insulation)
- 4) Unscrew the fan leads – you may need to remove the plastic cover of the screw terminal. (for your convenience, you may want to completely detach the fan/heater assembly from the printer – be sure to take note of leads(cables) positions into screw terminals!)
- 5) Remove the fan using the 8mm nuts (marked as 1-2, Figure 4.26.1) – four nuts total, two shown!
- 6) Replace with the new fan, be sure to mount it blowing toward the heater (notice the direction of arrow stamped on the fan)
- 7) Put back the four 8mm nuts
- 8) Restore electrical connections
- 9) Put back the heater/fan assembly on the rear cover
- 10) Put back the two remaining 8mm nuts to temporarily secure the heater/fan assembly
- 11) mount the rear panel with the eight screws
- 12) tighten the two 8mm nuts
- 13) Check that no cable is to be seen inside the printer
- 14) Turn on the printer, see if fan is turning
- 15) Using repetier Host, turn on heated chamber, see if you get any heating. You may need to wait 5-10 minutes to see any T change

4.27 Front Panel Removal

This procedure is valid for LCD / jogwheel / emergency button replacement as well.

SAFETY WARNING. CAUTION - BEFORE UNDERTAKING THE FOLLOWING PROCEDURE BE SURE TO PULL AC PLUG FROM WALL IN NO CASE MAINTENANCE HAS TO BE PERFORMED ON AN AC POWERED UNIT

Tools needed:

- 2.5mm hex key
- 5mm key
- UHU / PATTEX (or any solvent based general purpose glue)

- 1) Using the 2.5mm hex key remove the four screws holding the upper front panel (part 1 in Fig.4.22.1)
- 2) Remove the hex key holding the right cover (part 2 in Fig.4.22.1) – screws are both on right side and on machine rear

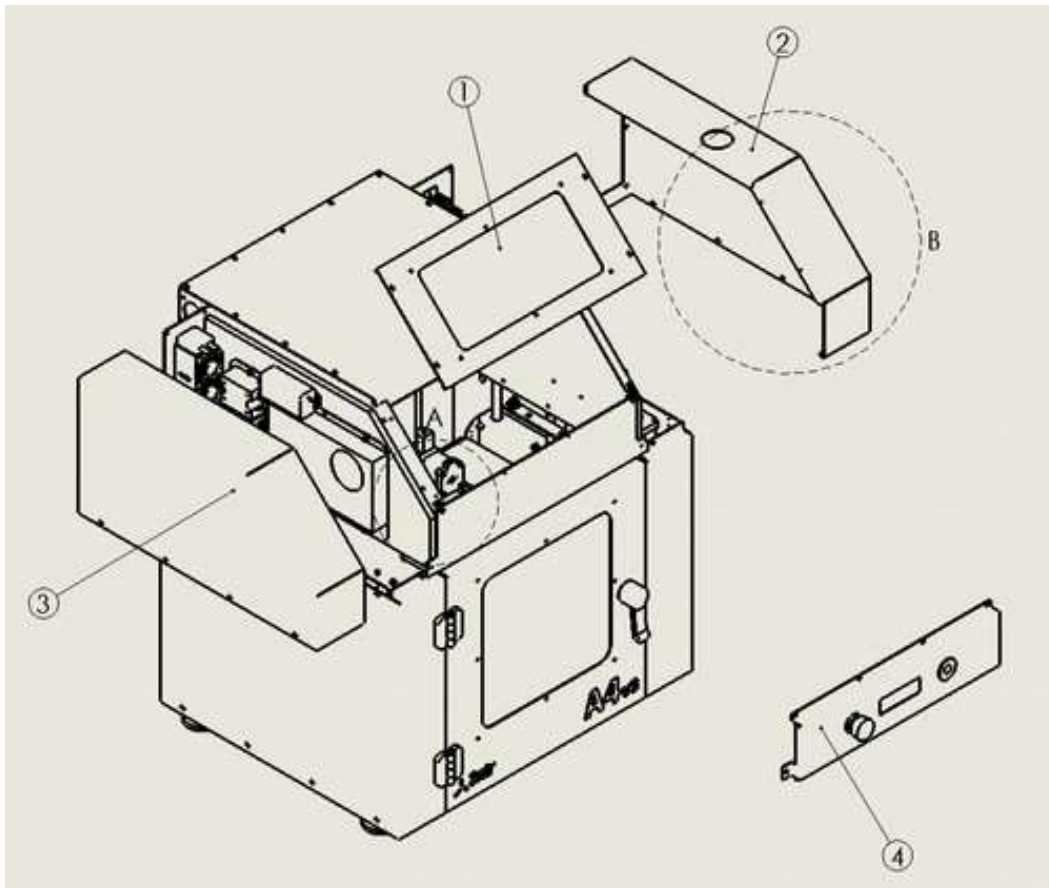

Figure 4.27.1 Panel Removal

- 3) Remove the screws inside the printing chamber (V1 and V2, Fig 4.22.2)

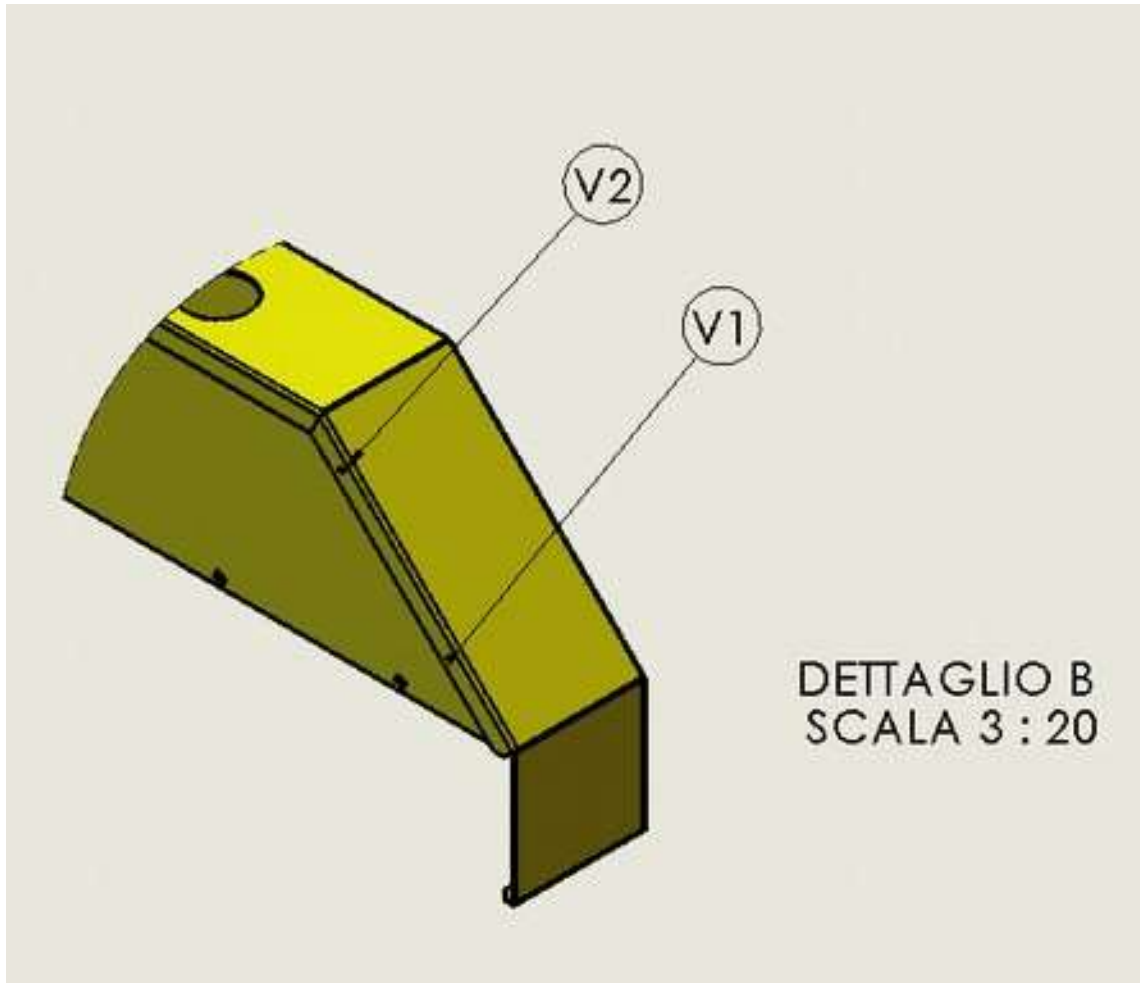

Figure 4.27.2 Right Cover Screw Locations

- 4) Right cover can be removed: gently lift it upwards to let it disengage from the water tank cap.
- 5) Same procedure applies to left cover (part 3 in Fig.4.22.1)
- 6) Remove the six screws holding the front panel assembly (part 4, Figure 4.22.1)
- 7) Open the printer door to get optimal clearance to remove front panel assembly.
- 8) Remove the selected part (LCD/Jogwheel/Emergency Button)



Figure 4.27.3 Rear View of Front Panel

- 9) Detach connector from motherboard (if LCD or jogwheel) or from safety relays (if emergency button)
- 10) Replace part
- 11) Restore electrical connection – jogwheel connector (“keyboard”) notch is facing UP on the motherboard, while LCD connector notch is facing DOWN on the motherboard.
- 12) If clear Plexiglas plate holding the jogwheel and LCD is moving, secure it with a solvent based glue (such as UHU or PATTEX)
- 13) Put back front, right and left covers
- 14) Restore AC power, test machine emergency button / LCD / jogwheel to be OK

4.28 Machine Packaging

Use the following images to properly re-package the printer before shipping.

CAUTION – Failure to place the printer on a suitable pallet and/or package the printer as shown can result in damage to the housing and mechanism.

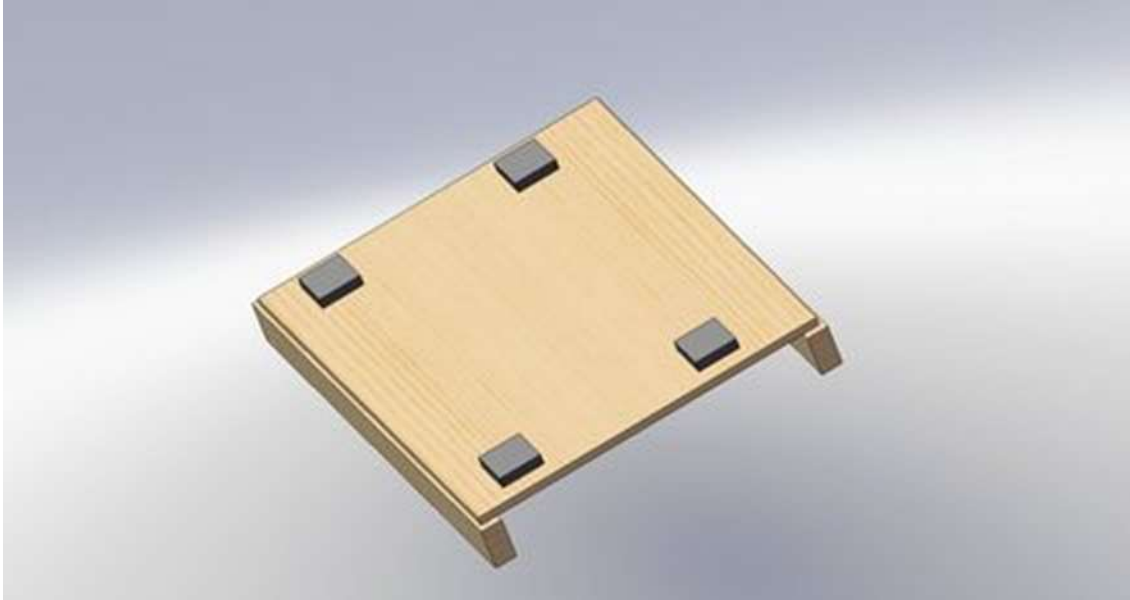

Figure 4.28.1 Printer Pallet with Pads

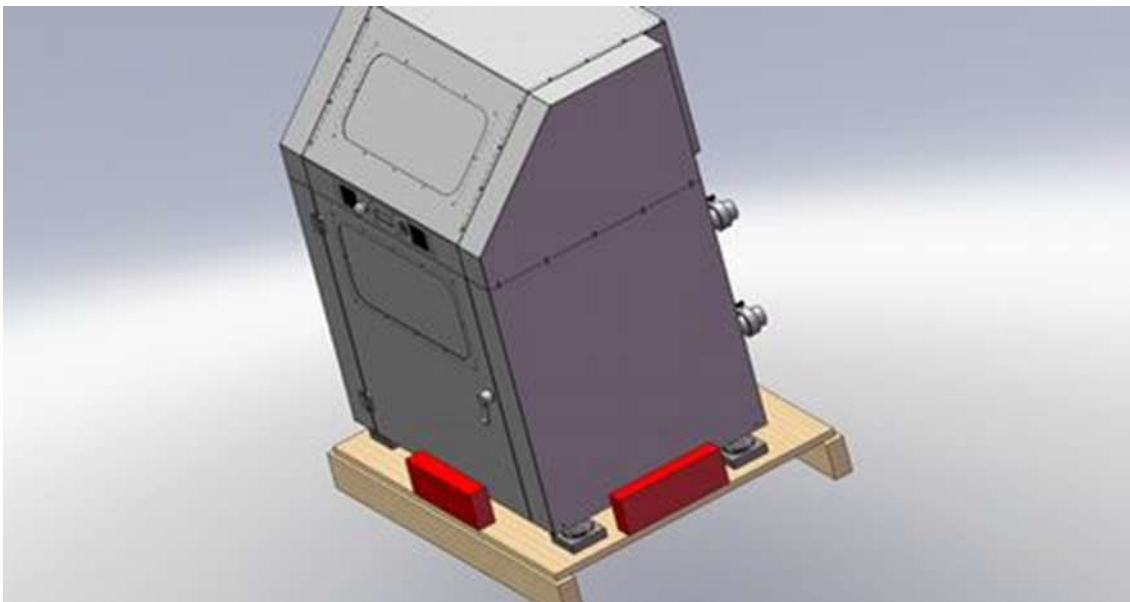

Figure 4.28.2 Printer on Pallet with Lower Side Blocks

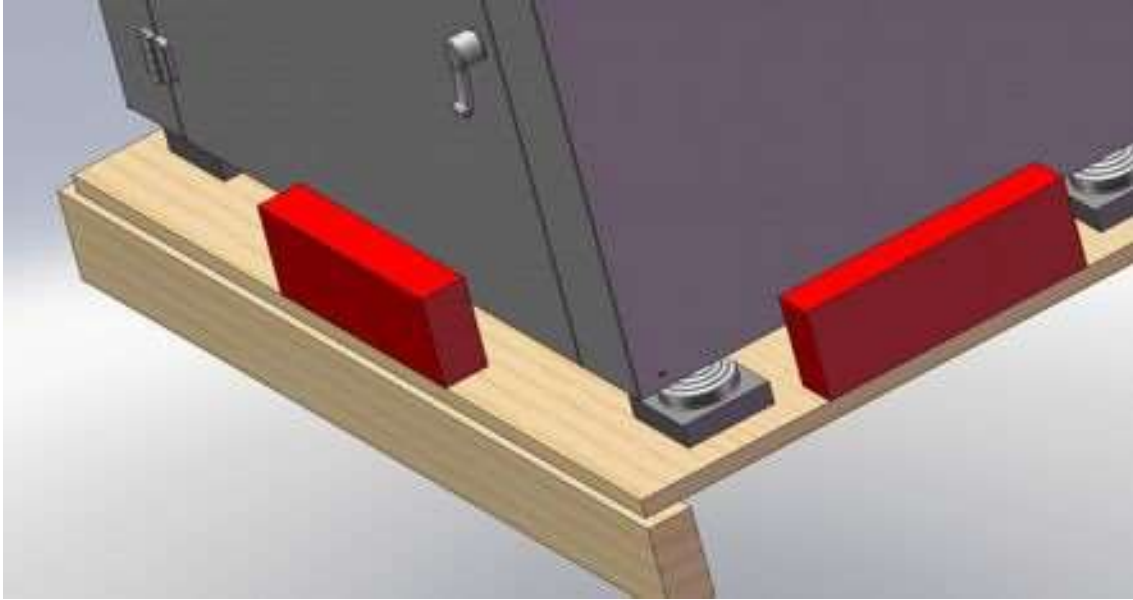

Figure 4.28.3 Pallet Detail – Side Blocks

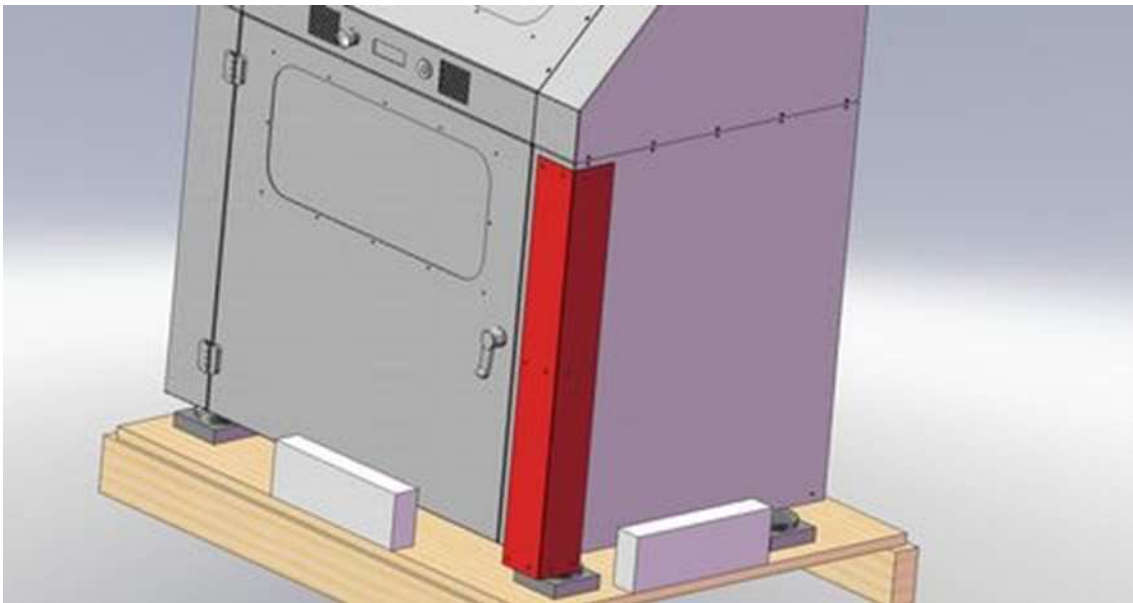

Figure 4.28.4 Printer Corner Protection

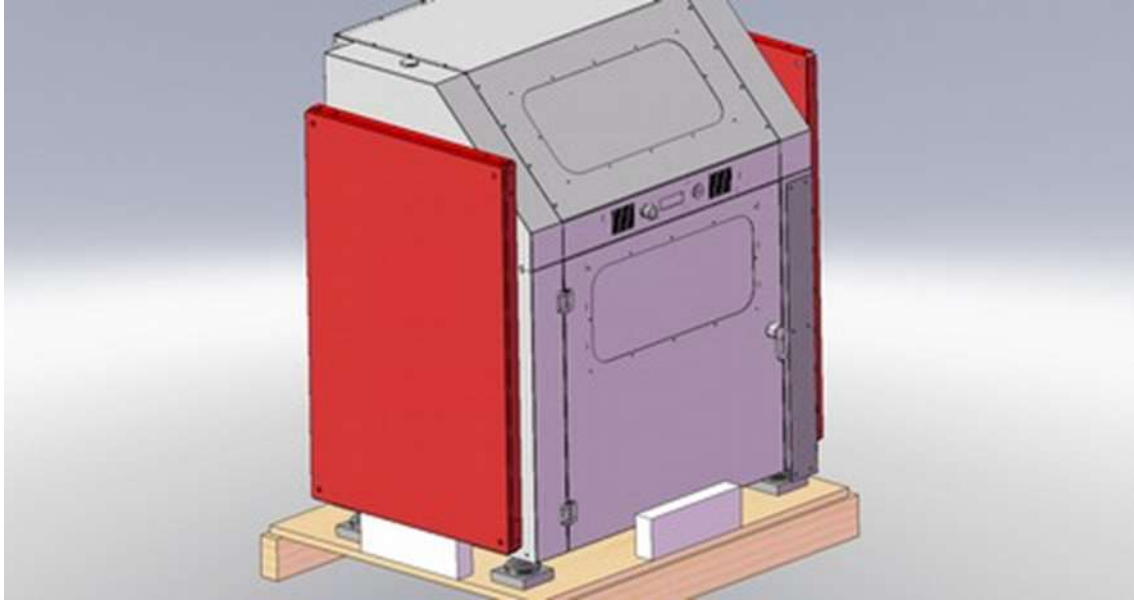

Figure 4.28.5 Printer Side Protection Padding

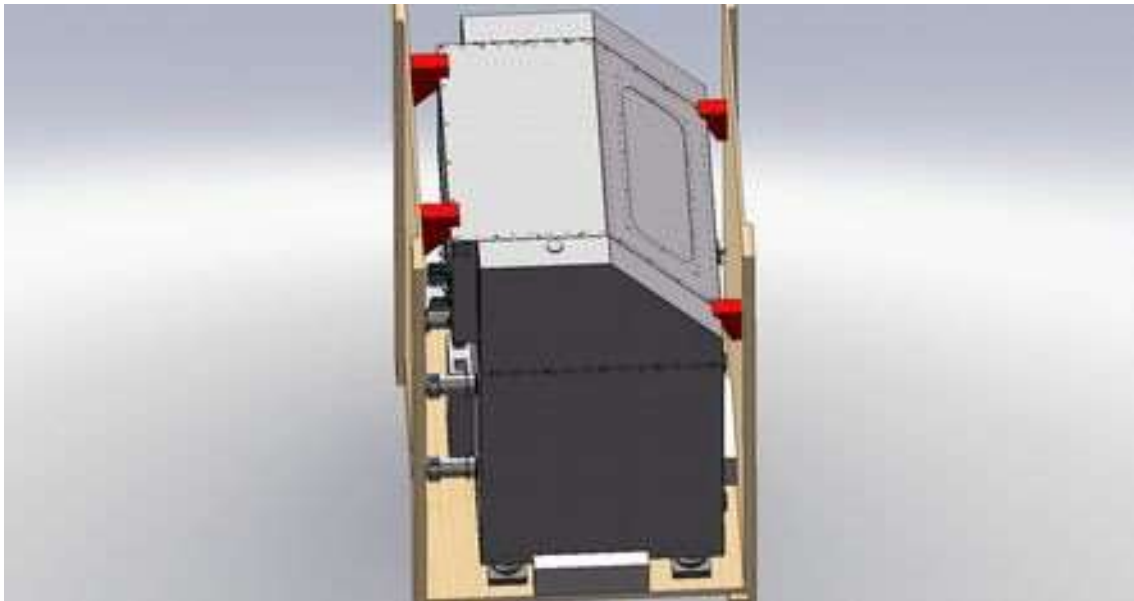

Figure 4.28.6 Front and Rear Printer Crate

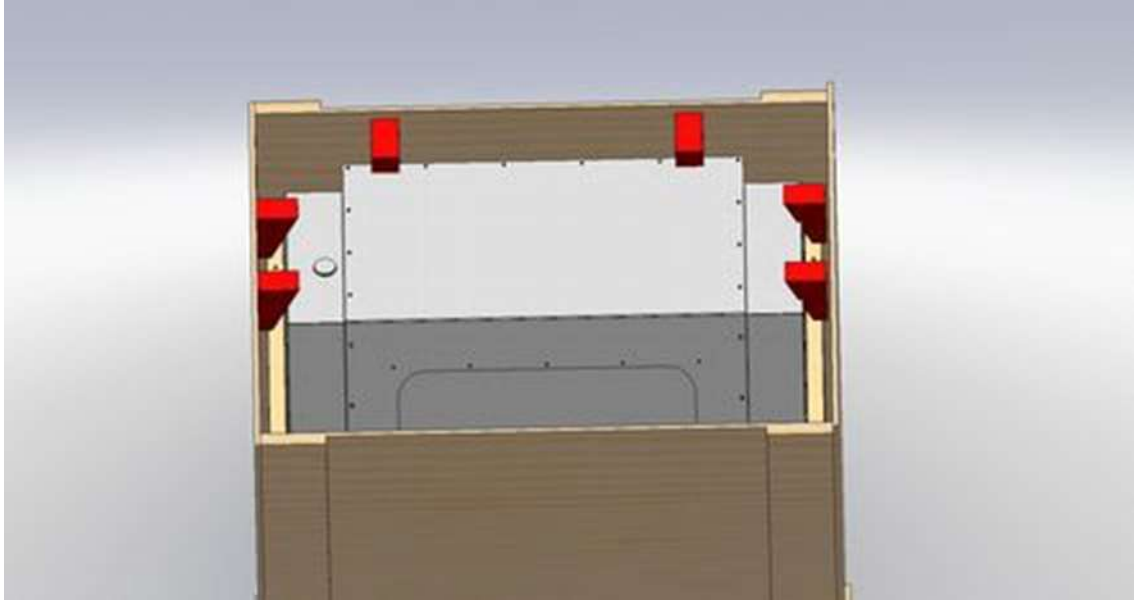

Figure 4.28.7 Printer Crate Sides and Top Padding

4.29 Extruder Plate Change

It may be required if you are updating an older machine to new standard or if the extruder assembly has been hit/damaged during Z plate lift (i.e.: faulty Z sensor/operator error)

- 1) Remove extruder cooling block

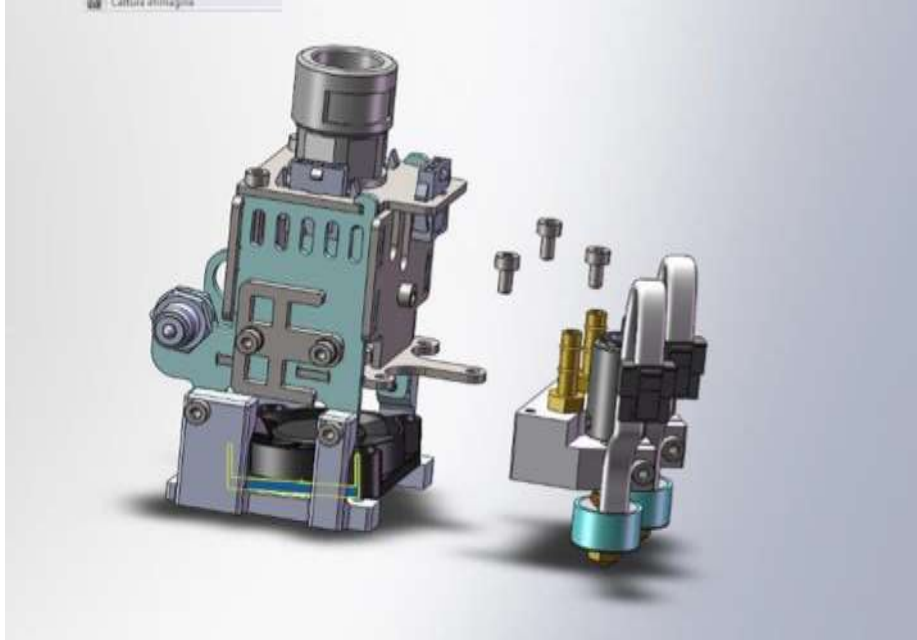

Figure 4.29.1 Remove Extruder Cooling Block

- 2) Remove fan holder



Figure 4.29.2 Remove Fan Holder

- 3) Detach fan and end stop connectors them remove connectors plate

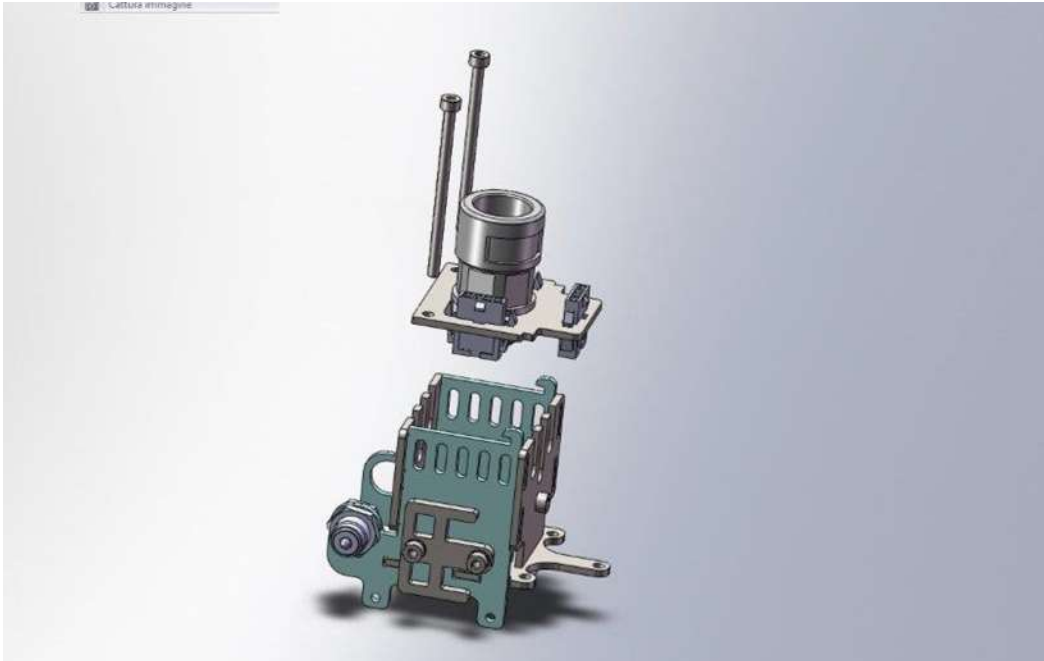

Figure 4.29.3 Detach Fan and End Stop Connectors/Plate

- 4) Place holder bracket

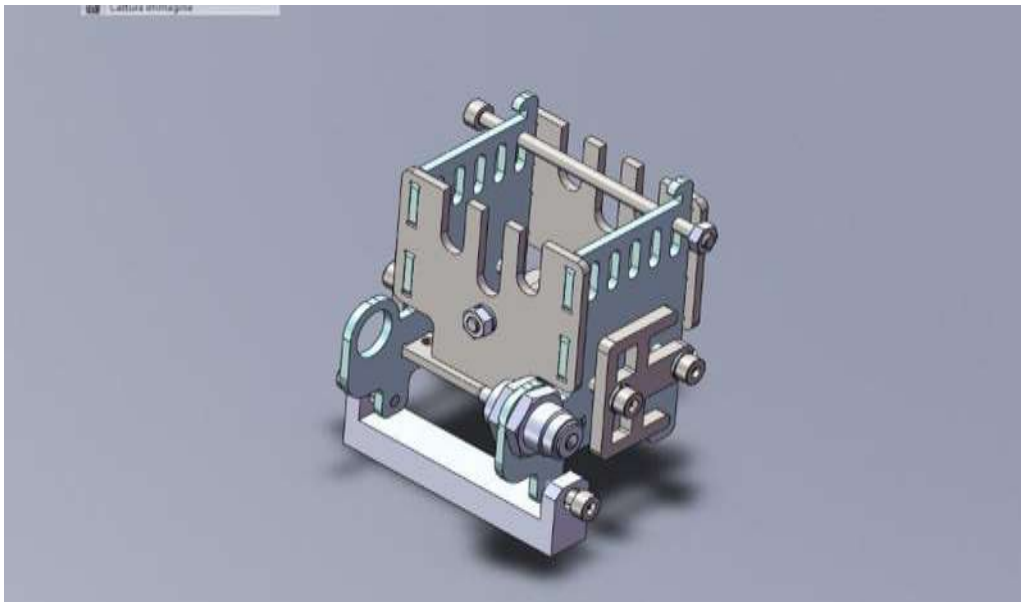

Figure 4.29.4 Place Holder Bracket

- 5) Place safety hold screw, then remove back and rear plates

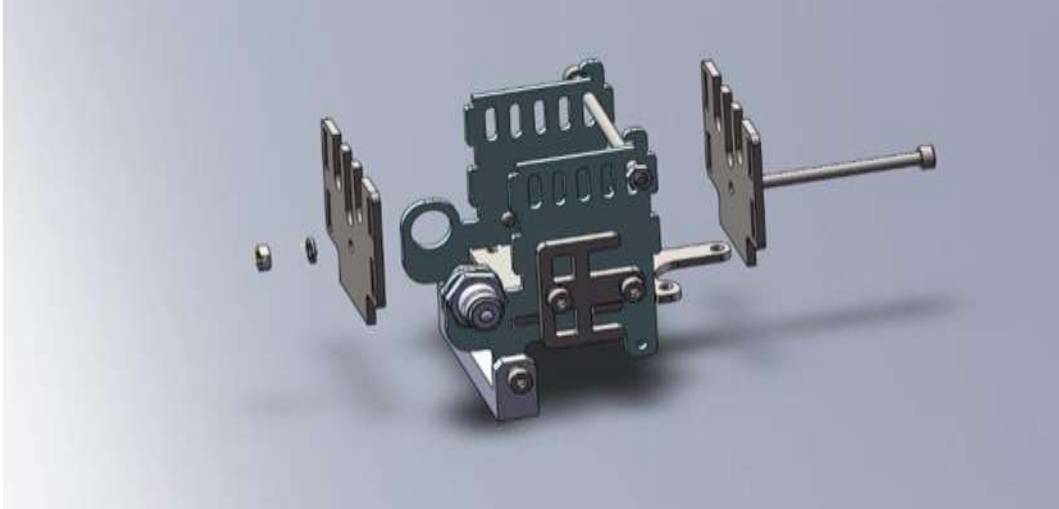

Figure 4.29.5 Place Safety Holder Screw, then Remove Back and Rear Plates

- 6) Gently pull apart belt-holding plates

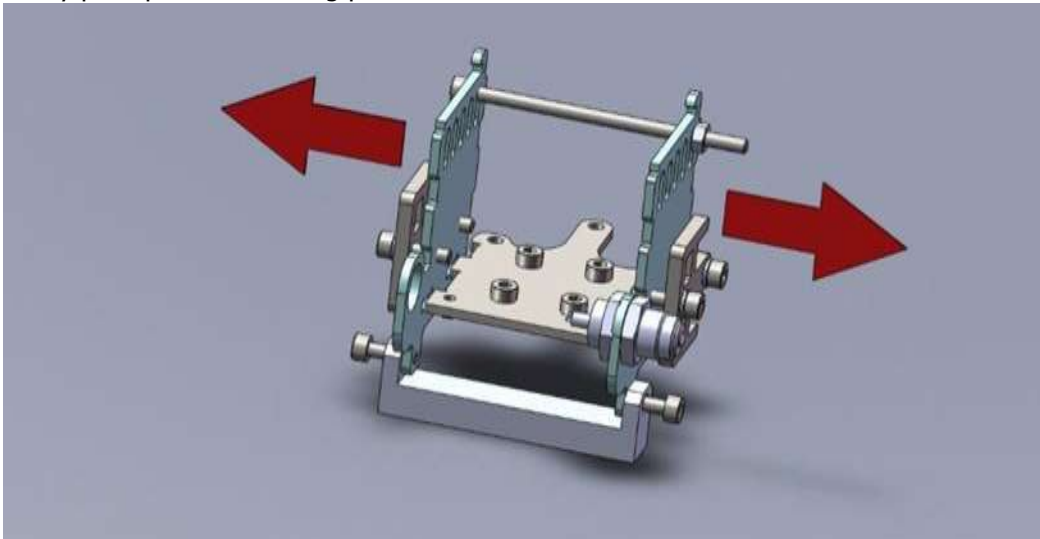

Figure 4.29.6 Pulling Apart Belt Holding Plates

- 7) Replace extruder block holder plate, then reverse procedure to re-assemble

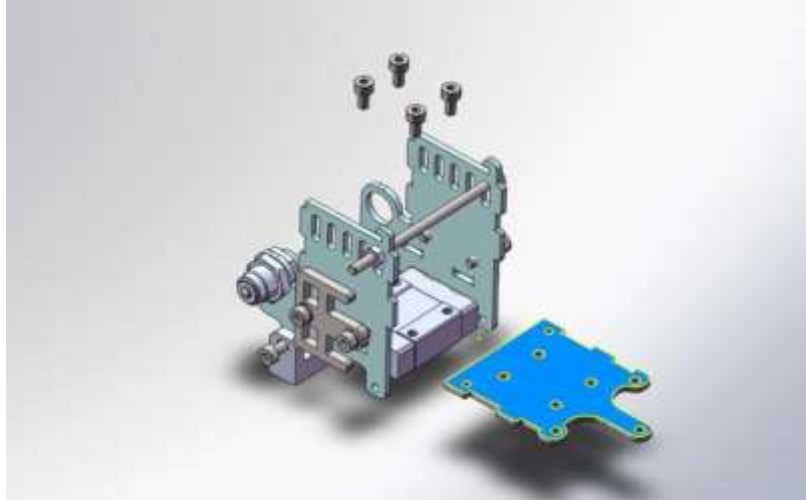

Figure 4.29.7 Extruder Block Holder Plate

4.30 Print Plate Repair Procedure

Before starting this procedure, you will need:

- A syringe with black glue
- Magnets to be glued
- Hardware tools to clean holes (ie, sanding paper)
- Masking labels
- A printer of the same type for the plate being repaired (to later cure it)

Repair Procedure:

- 1) Clean the magnet hole on the printer plate
 - Clean any glue residual from the hole
 - Be sure that magnets have some clearance to let glue penetrate between carbon fiber and magnet walls – use a drill bit or a le to get to a bigger clearance if needed
 - Do not force the magnet into the hole
 - Be sure to remove any dust



Figure 4.30.1 Printer Plate Corner Hole

- 2) Apply the masking label on the lower tray side (the one touching the hot plate)

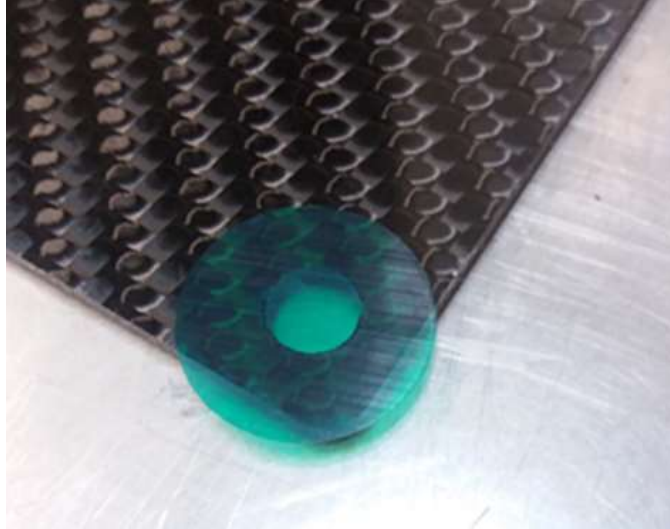

Figure 4.30.2 Masking Label on Lower Plate Side

- 3) Get the magnets. Let them stick to the hot plate (at room temperature – not to harm yourself)

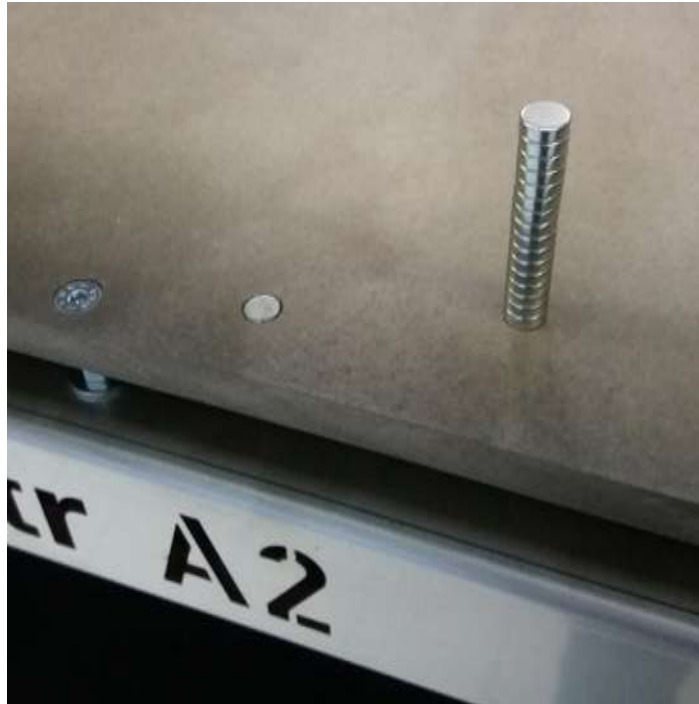

Figure 4.30.3 Magnet Stack

- 4) Mark the upper face of the magnet stack (while placed on hot plate magnet)



Figure 4.30.4 Mark the Magnet Stack

- 5) Place the magnet into the masked hole, marked side UP

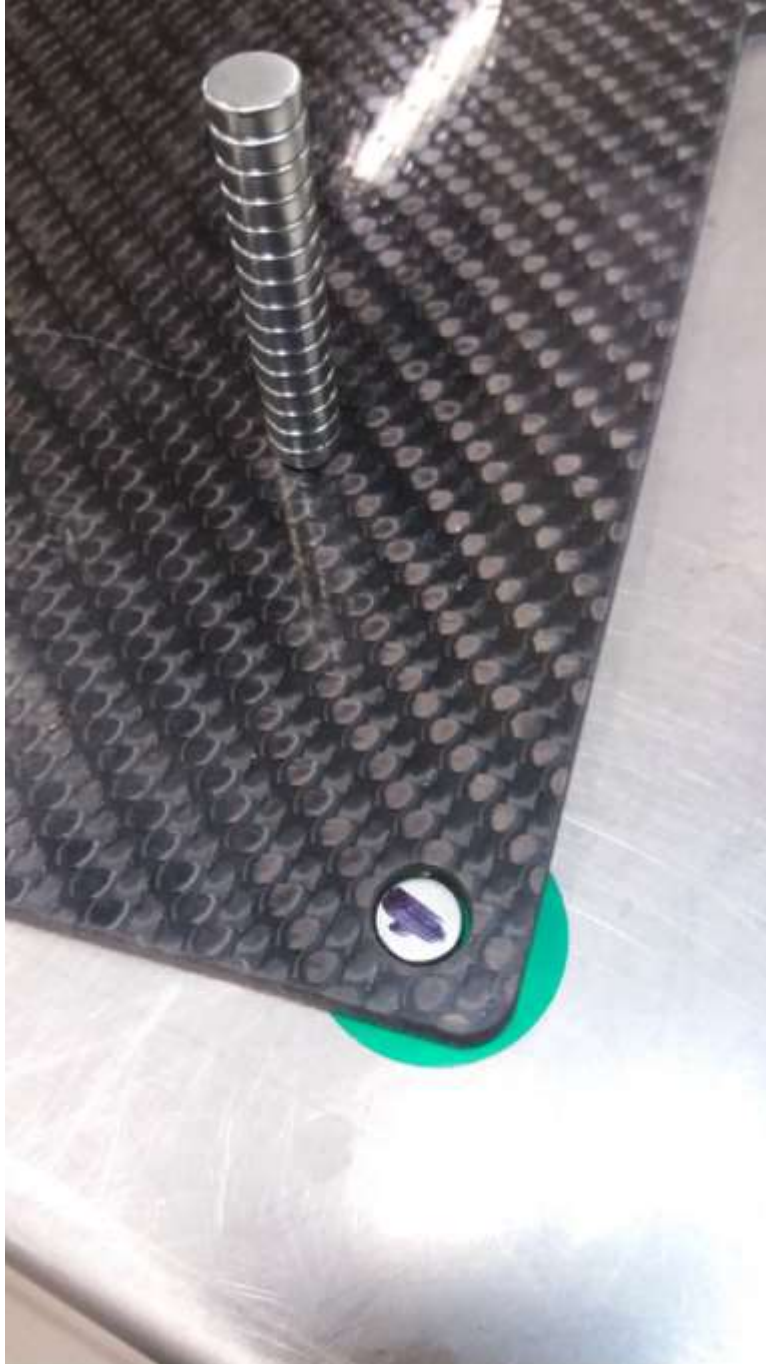

Figure 4.30.5 Magnet in Printer Plate Corner Hole

- 6) Set heated bed at 100° C. Wait for temperature to settle.
Be sure to have magnet away from any heated bed magnet



Figure 4.30.6 Plate with Magnet in Corner Hole on Heated Bed

- 7) Put a SMALL drop of glue on the magnet. Let it get warm and more fluid – it will penetrate the space between magnet and carbon plate.
- 8) Add glue drops until you coat the magnet. Don't exceed with glue – avoid getting a “bubble” that protrudes above plate level

NOTE - Be sure to keep the syringe with unused glue into a cold storage (fridge is OK)



Figure 4.30.7 Applying Glue to Magnet

- 9) Inspect. This is how should be looking for a good quality job:
Glue is BELOW the plate level, yet you don't see it anymore the magnet surface



Figure 4.30.8 Completed Glue Application to Plate Magnet

- 10) Let it cure with supplied GCODE.
Just in case, below are the gcode program lines needed for curing:
M190 S100
M117 CURE 1
G4 S1800
M190 S120
M117 CURE 2
G4 S1800
M117 DONE
M190 S10
- 11) After curing, let plate cool down one hour before moving/using it.
- 12) Remove masking label before use!

4.31 Very High Temperature Hardware/Firmware Modification

Standard machines can reach 350°C: to get up to 450° you need to apply both hardware and firmware upgrade. Here is the procedure:

- 1) Turn OFF machine.
- 2) Gain access to the motherboard area – remove front and side panels.
- 3) Be sure to have at hand the thermocouple adapter and auxiliary power supply.

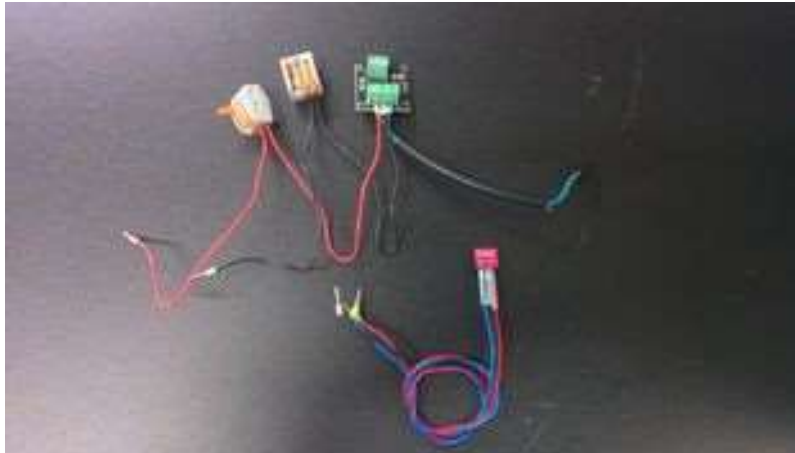

Figure 4.31.1 Power Supply and Thermocouple Adapter

- 4) Connect the thermocouple adapter:
 - There are two connectors on the motherboard – left is for #3 and right is for #2 (pictured is for #2).
 - Be absolutely sure that the RED lead (severed) is on the upper position. Failing to comply will fry the board.

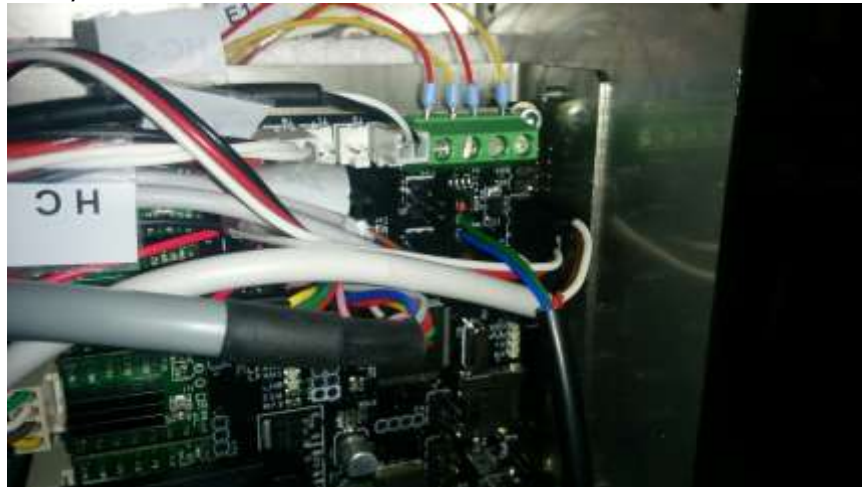

Figure 4.31.2 Thermocouple Adapter Connection

- 5) Remove thermocouple leads from motherboard

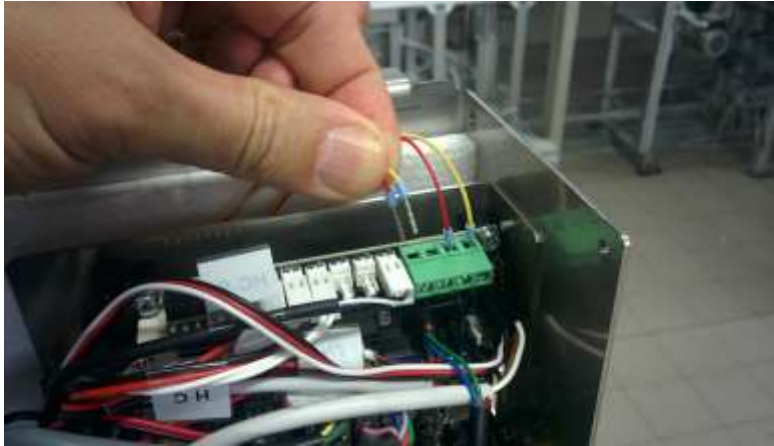

Figure 4.31.3 Removing Thermocouple Leads

- 6) Put the leads on thermocouple adapter

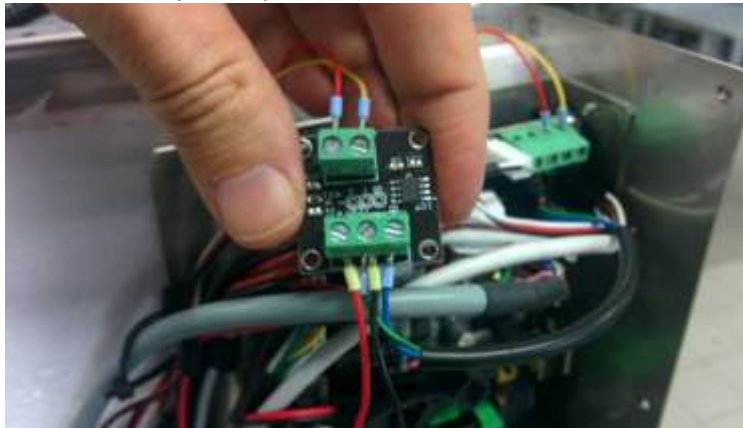

Figure 4.31.4 Connecting Thermocouple Leads to Adapter

- 7) Connect the (+) pole of the auxiliary power supply (blue lead) on the fourth terminal from right on the lower motherboard area



Figure 4.31.5 Auxiliary Power Supply Connection



Figure 4.31.6 Auxiliary Power Supply



Figure 4.31.7 Connecting Leads from Auxiliary Power Supply

- 8) Connect leads from the auxiliary power supply:
 Red on the leftmost (must be the **ONLY LEAD** there)
 Black on the middle one (must be along with the lead going on the motherboard connectors)

IMPORTANT: in case of upgrade of extruder #3, the existing red lead must be cut out from the cable going to the motherboard (as shown in the picture, near the thumb).

- 9) If you are applying above modification to #3 repeat above steps (be sure that motherboard connection is on the **LEFT** place)
- 10) If there is just one extruder affected by the modification, remove redundant wires as shown

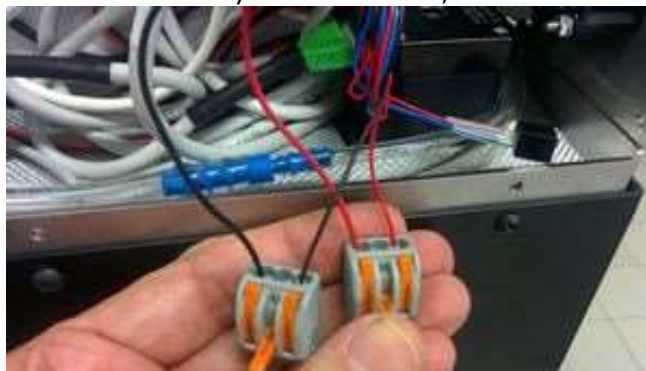

Figure 4.31.8 Removing Redundant Wires – Single Extruder Modification

- 11) Apply adequate firmware update: Be sure to run CLEANER firmware before loading the new HT one (failing to do so can get you into unpredictable behavior)



Figure 4.31.9 LCD Display During Firmware Update

4.32 Print Server Stops Working

One reason can be depleted memory due to too many video recordings.

Remedy:

- 1) Console access to print server (or SSH with putty)
- 2) Remove some videos (one directory each) into directory
/var/lib/Repetier-Server/Printer/A2V2/time lapse or
/var/lib/Repetier-Server/Printer/A4V3/time lapse
- 3) send the command
sudo reboot
- 4) Server will reboot and regain control

4.33 Print Server – Lost Password

If you enabled access control on the print server but forgot your password, and there is not any other administrator account available, the only way out is deleting all user accounts.

- 1) Log on the print server using Putty
- 2) Stop the print server
"sudo service repetierserver stop"
- 3) Delete the user database:
"cd /"
"cd var/lib/Repetier-Server/database"
"rm user.sql"
- 4) Restart server to rebuild the user database (NOW ANYONE WILL BE ABLE TO LOGIN)
"sudo service repetierserver start"

4.34 Print Server – Files Disappeared

This occurs if print server loses power when receiving a file.

To restore sanity:

- 1) Log into print server using Putty
- 2) Insert following command:
"cd /"
"cd var/lib/Repetier-Server/printer"
"sudo mc"

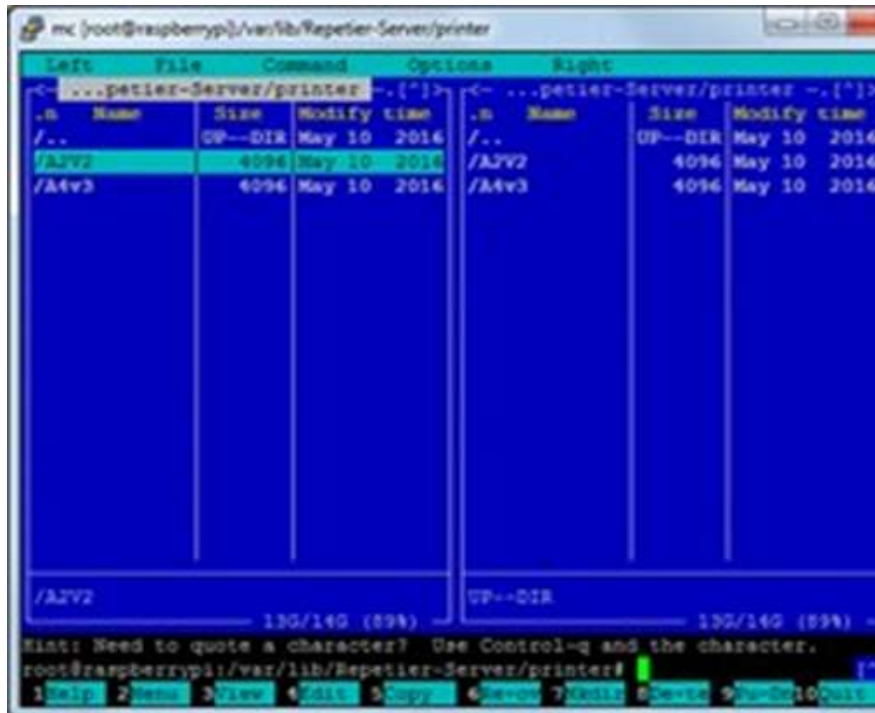

Figure 4.34.1 Screen After 'sudo mc'

- 3) You will be shown the printer names of active/defined models on your print server
- 4) Choose the directory of disappearing files.
- 5) Get into "jobs" directory.

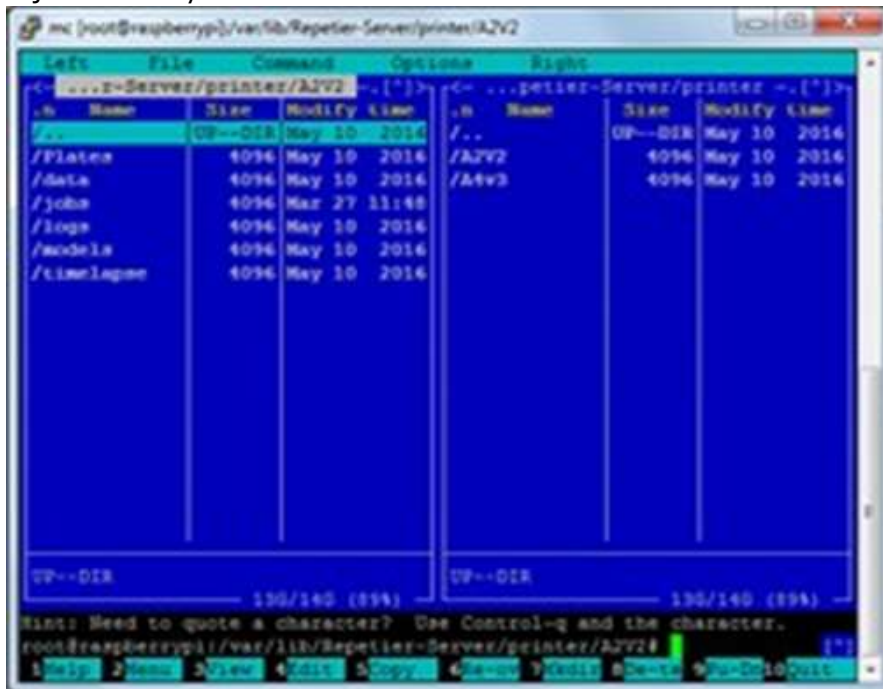

Figure 4.34.2 Jobs Directory

- 6) Delete the *.linfo file (the file ending with linfo) : move cursor over selected file then press F8
- 7) Press F10
"sudo reboot" to restart.
- 8) System will rebuild itself and files will reappear.

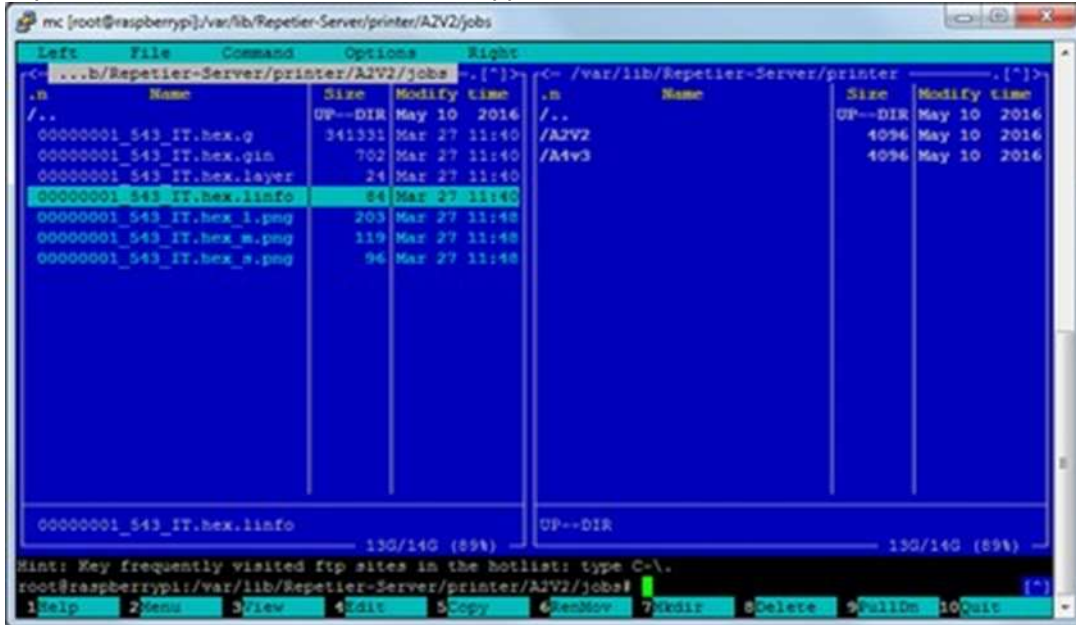

Figure 4.34.3 Screens After "sudo reboot"

4.35 Print Server – Files are Visible, but Won't Print

This has to do with some issues with files. Following the "disappeared files" procedure on previous chapter should fix it. If you still are not able to print, just delete all files (you will lose everything – gcodes and time lapses):

- 1) Log into print server using Putty
- 2) Insert following commands:
"cd /"
"cd var/lib/Repelier-Server/printer"
"sudo mc"



Figure 4.35.1 Files after "sudo mc"

- 3) You will be shown the printer names of active/defined models on your print server
- 4) Choose the directory of disappearing files
- 5) Get into "jobs" directory
- 6) Delete the *.linfo file (the file ending with linfo) : move cursor over selected file then press F8 delete all files into "models" and "timelapse" directories
- 7) Press F10 "sudo reboot" to restart.
System will rebuild itself and files will reappear.

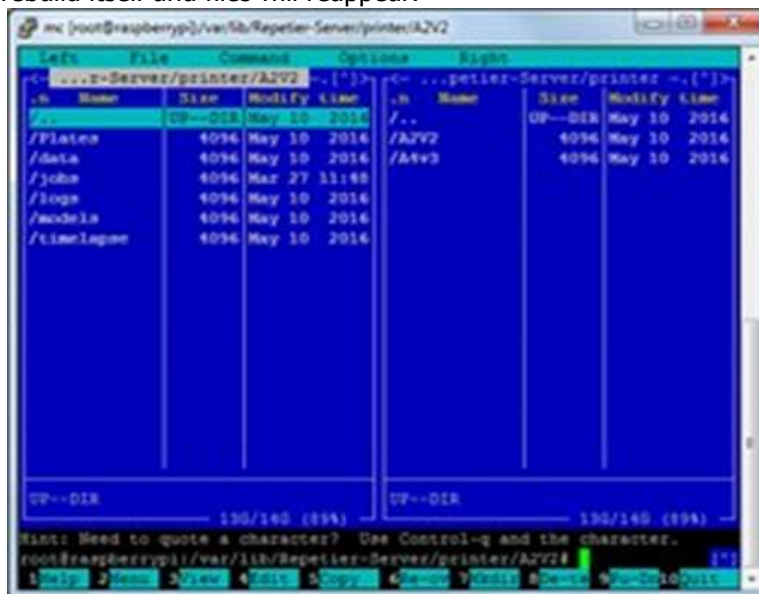
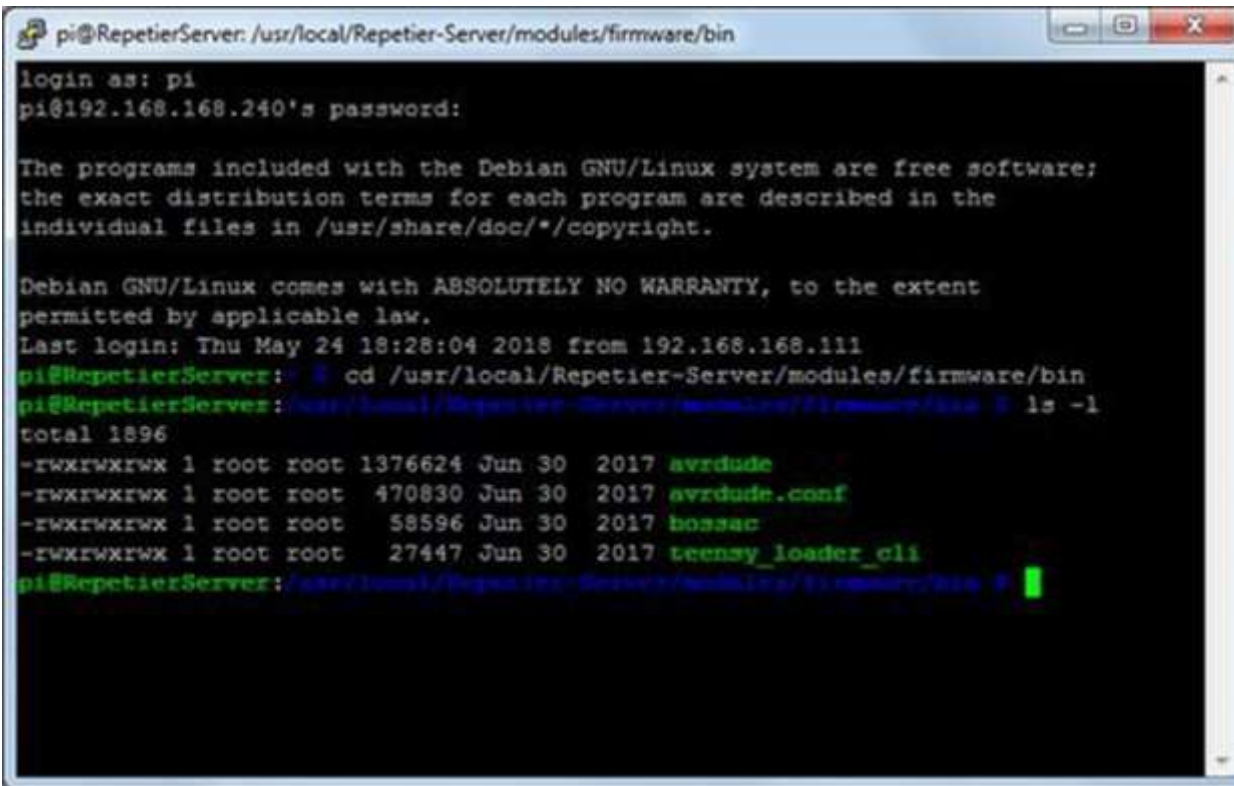

Figure 4.35.2 Files after System Rebuild

4.36 Print Server – Firmware won't flash anymore

For some reason, the permissions of the programs to be run to flash the firmware lost the original permissions. To restore them:

- 1) Log into print server using Putty
- 2) Insert following commands:
"cd /"
"cd /usr/local/Repetier-Server/modules/firmware/bin"
"ls" will give you the listing below. The left part of the listing MUST BE "rwxrwxrwx". If it is like that, then your print server install is OK. If not, go on reading



```
pi@RepetierServer: /usr/local/Repetier-Server/modules/firmware/bin
login as: pi
pi@192.168.168.240's password:

The programs included with the Debian GNU/Linux system are free software;
the exact distribution terms for each program are described in the
individual files in /usr/share/doc/*/copyright.

Debian GNU/Linux comes with ABSOLUTELY NO WARRANTY, to the extent
permitted by applicable law.
Last login: Thu May 24 18:28:04 2018 from 192.168.168.111
pi@RepetierServer: ~$ cd /usr/local/Repetier-Server/modules/firmware/bin
pi@RepetierServer: /usr/local/Repetier-Server/modules/firmware/bin$ ls -l
total 1896
-rwxrwxrwx 1 root root 1376624 Jun 30  2017 avrdude
-rwxrwxrwx 1 root root  470830 Jun 30  2017 avrdude.conf
-rwxrwxrwx 1 root root   58596 Jun 30  2017 bossac
-rwxrwxrwx 1 root root   27447 Jun 30  2017 teeny_loader_cli
pi@RepetierServer: /usr/local/Repetier-Server/modules/firmware/bin$
```

Figure 4.36.1 Data Display After "Is I" Command

- 3) "sudo chmod a+rwx*"
- 4) Logout. Try flashing again – it should be possible now

4.37 Filament Sensor Doesn't Work/Works Intermittently

If the Filament Sensor doesn't work or works intermittently, perform these checks to determine one of the possible reasons:

- 1) Check the connector on motherboard
- 2) Check filament quality/diameter – thin ones may trigger sensor
- 3) Check the connectors on each filament sensor
- 4) Open each sensor
 - o Clean from powder or any filament residual
 - o Check that soldered on sensor (g.18 – 2) ends are OK

- Plastic roller (g.18 - 1) is in place and free to move
 - Microswitch (g.18 – 2) is working OK
- If everything OK, put back cover on sensor(s)
- 5) G-code correctly enables the sensor (M11)
 - 6) To validate installation:
 - 1) Be sure that ALL sensors have been fitted with filaments
 - 2) On two-nozzle machine: be sure that there is a jumper on the unused branch of cable assembly (you may need to open the cable cover inside heated chamber)
 - 3) Connect to machine (PC or print server)
 - 4) Send M119 command. Machine will reply with "filament_runout_pin: NOT TRIGGERED " if everything is OK.
 - 5) Remove a filament and again sending an M119 command you must get a "filament_runout_pin: TRIGGERED " reply.
 - 6) If not, check again connections

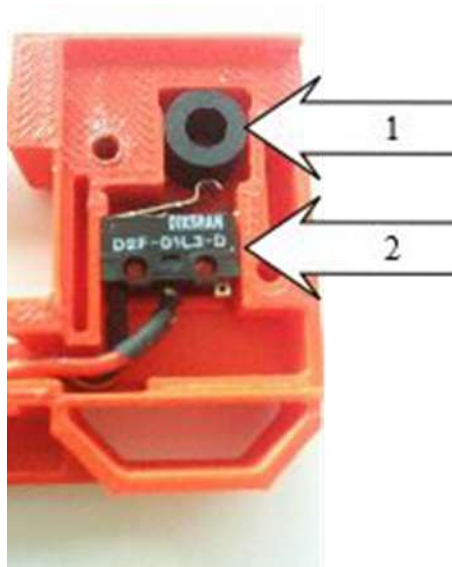

Figure 4.37.1 Filament Sensor

4.38 Printer Jams frequently – Cooling Circuit jammed

In case you are experiencing one of the following situations:

- SSU0 (or other low-temperature filament) is giving printing problems/jams into entry at upper part of the extruder
- Support polymer doesn't stick properly to raft/part
- You are unable to remove filament from extruders
- Plastic pipes entering/exiting the extruder holder block are showing some dark colored spots
- Plastic pipes entering/exiting the extruder holder block are showing some "cloudy" substances



Figure 4.38.1 Extruder with Jam on Entry

You should check the cooling system:

- 1) Turn power off and unplug printer from AC socket
- 2) Remove the panel covering the water reservoir/pump assembly (A2 is at left, A4 is at right)
- 3) Using suitable devices, completely empty the reservoir
- 4) Detach pump outlet (lower pipe) and place it into a 1-2 lt empty plastic bottle (keep a towel at hand to avoid any spill – if water leaks around, **BE ABSOLUTELY SURE THAT EVERYTHING IS COMPLETELY DRY BEFORE POWERING ON MACHINE**)
- 5) Detach inlet tube (it is the highest positioned pipe attached to the reservoir) and plug it into lower port (pump outlet)

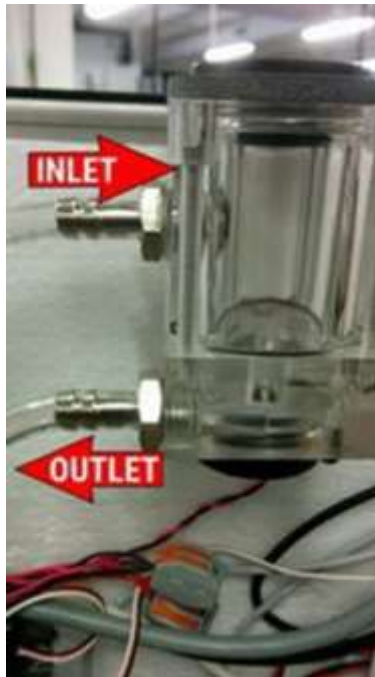

Figure 4.38.2 Inlet/Outlet Identification on Coolant Reservoir

- 1) Fill the reservoir with tap water – don't reach the inlet port level (you could spill it into LIVE ELECTRICAL DEVICES LATER ON)
- 2) Turn on machine – pump will work in the opposite way it was working (possibly removing any obstruction into pipes) If there is no water flow, chances are that extruder holder block is jammed. Take the following extra steps:
 - a. drain all the liquid from the cooling circuit
 - b. remove all extruders from the machine
 - c. unplug machine from AC power
 - d. pull and detach piping entering the extruder block
 - e. use compressed air to blow inside both entry points into extruder holder block
 - f. when air is freely flowing in BOTH ports, re-connect piping to the extruder block and restart from #6 (fill reservoir)
 - g. Keep adding water to the tank to the tank to get complete pipe cleaning
- 3) If water is still not flowing, turn power off – turn power on and:
 - a. Check all piping that no sharp bends are obstructing flow
 - b. Check that no pipe is being pinched by metal panels – remove all relevant panels to check piping
 - c. Check that pipes into extruder holder assembly are not bent into connector area
 - d. When water flow is steady (and works even when pump is powered off) let the circuit to completely drain
 - e. Using DEMINERALIZED PURE WATER (same grade used for batteries) ll again the circuit and add until circuit is completely clean from any tap water residual
 - f. Let the circuit to completely drain
 - g. Turn power off and detach power cord
 - h. Restore original piping condition (inlet and outlet connections)
 - i. Fill system with de-mineralized water. Turn machine on
- 4) Tapping on inlet port, remove any air bubble trapped into heat exchanger – you must feel subtle pressure on inlet port flow entering the reservoir
- 5) Be sure that water level is OK
NOTE - Using pure de-mineralized water is approved alternative to factory supplied blue tinted liquid.



Figure 4.38.3 Poor Cleaning Results Due to Cooling Problems

4.39 Print Looks Bad – Stripes

If you are experiencing horizontal banding or irregular horizontal stripes on your print, chances are that the Z movement has problems.



Figure 4.39.1 Horizontal Banding on Lower Portion (Motherboard Fan Unplugged)

Checklist (from most probable to the least possible chance):

- Unplugged or broken motherboard fan (not cooling the Z driver, it will overheat and not work constantly)
- Bottom synchronization belt too tightened – release it a bit

- Defective stepper driver (temporary test: swap the Z driver with extruder #3 or #2 –check power setting)
- Z screw movement is irregular: check coupling (screw-motor) and bearings (fully seated into bottom plate)
- Dirt trapped on screw nuts: remove any contamination and clean area. Use a clean cloth to remove any dirt traces from screws. This could be a symptom of hairspray (or any other aerosol contaminant) being used INSIDE the printer.
- Broken-defective Z leadscrews/nuts: dismount machine and inspect.
- Defective Z motor-gearbox
- Defective motor cabling (loose crimp)

4.40 X/Y/Z Axis Won't Move

If the selected axis doesn't move check as follow:

- Cable from motherboard to stepper motor is OK (fully seated and undamaged)
- Stepped motor driver is fully seated into motherboard
- (X or Y) pulley is firmly locked on motor shaft
- (Z) motherboard fan is running
- stepper driver current is OK

If above checks are OK, there are three possible reasons:

- 1) Faulty stepper driver: swap with a filament feeder driver (upper three topmost positions) and see if it moves. If yes, be sure to adjust current.
- 2) Faulty cable – try a temporary replacement with a spare cable (or get one temporary off the filament feeder)
- 3) Faulty stepper motor (VERY, VERY RARE): replace motor

4.41 Z Safety Switch Installation/Calibration

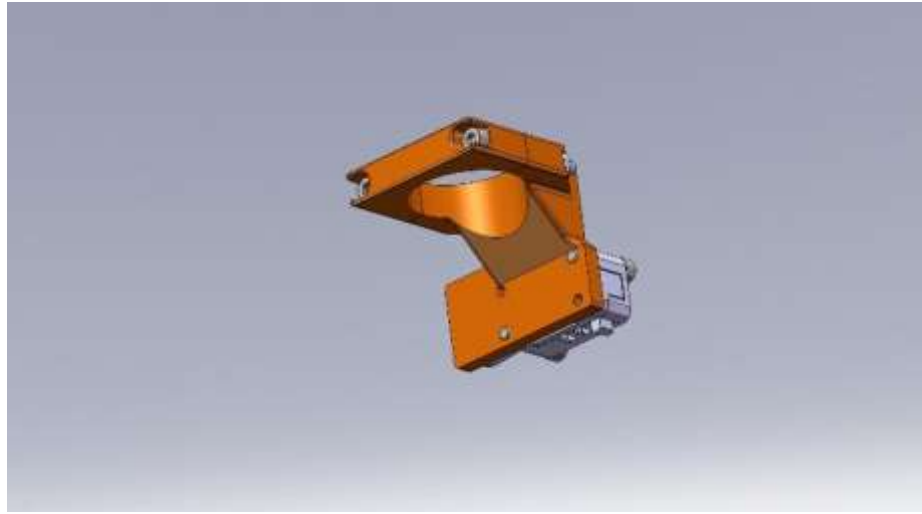

Figure 4.41.1 Z Safety Switch

- 1) Move plate (Z) down about to 60-80mm
- 2) Remove upper right cover (to gain access to motherboard)
- 3) Connect cable leads to (4) and (5)

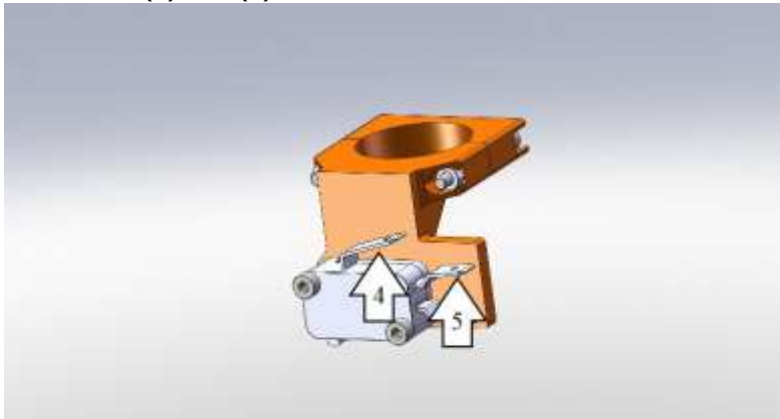

Figure 4.41.2 Cable Lead Connections

- 4) Fit safety switch on Z arm assembly as shown. Clamp part on Z assembly using screws (1) and (2)

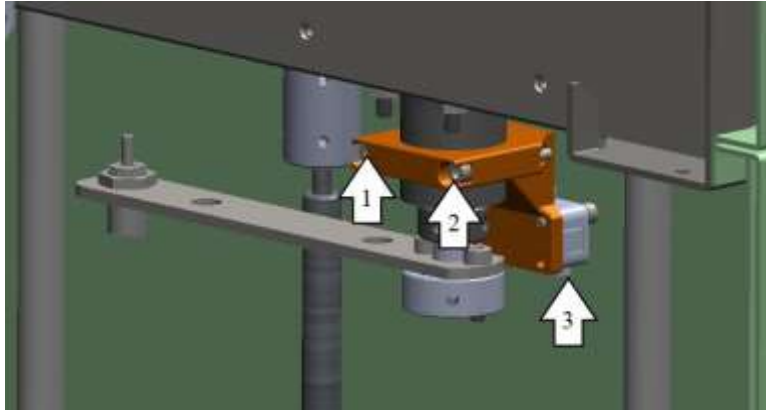

Figure 4.41.3 Safety Switch on Z Arm Assembly

- 5) Lock Z safety switch at highest position possible
- 6) Route Z safety switch cable along with existing Z sensor cable, until reaching the motherboard.
- 7) Connect Z safety switch to ZMAX pins (at the right of existing Z min switch)
- 8) From LCD menu, run the Z homing command. BE SURE THAT TRAY IS CORRECTLY PLACED INTO MACHINE
- 9) Move Z plate down 0.5mm
- 10) Release (1) and (2) screws, slide down sensor until tip (3) touches the Z holding part.
- 11) Lock safety switch into this position using screws (1) and (2)
- 12) Test Z homing with tray in place.
- 13) Z offset test print must confirm actual setting.
- 14) Test Z homing without tray in place: safety switch will cause homing to keep nozzles away from heated plate.

4.42Z Safety Switch is triggered – machine is locked

This is an expected behavior to save machine from crashing plate against nozzles.

To regain control of the machine, lift the Z switch assembly (step #5 of Z switch mounting procedure) then check reason for triggering, that could be one of the following:

- Lack of printing tray
- Z arm servo KO
- Z arm sensor KO
- Part on plate preventing arm deployment

Once problem is fixed, perform Z safety switch calibration.

4.43 Appendix A – Testing for Shorts (Continuity)

You may want to be sure that current is flowing (i.e.: fuse) and sometimes you want to be sure it isn't (i.e.: between machine frame and any power lead). In both cases, you need a multimeter.

Let's see how to test a fuse:

Set your multimeter into "continuity" mode.

Some models will also emit a sound when current can flow.



Figure 4.43.1 Multimeter Set to Continuity Mode

If you touch probes, display will change (and possibly hear a beep)



Figure 4.43.2 Checking Multimeter Function – Touch Probes

This fuse is blown. Discard it.



Figure 4.43.3 Multimeter Indicating Blown Fuse

This fuse is good – it works!



Figure 4.43.4 Multimeter Indicating Fuse OK

4.44 Appendix B – How to Test Voltage

You may test AC or DC voltage: be sure to switch multimeter to appropriate setting. In both case you must be careful with probes: Be sure that probes are touching just the test points – avoid touching any metal part of the machine. You may permanently damage machine parts.

If you are testing AC voltage be absolutely sure not to touch the metal tips of the probe while measuring – **DEATH RISK!**

Testing AC Voltage on Contactor Entry



Figure 4.44.1 Testing AC Voltage on Contactor Entry

Multimeter set to measure AC voltage. 228 VAC present on entry.



Figure 4.44.2 Correct 228 VAC Entry – MM Set to AC

If you are measuring DC voltage, red lead goes onto (+) and black lead goes onto (-) points.
Testing 24Vdc output on PSU terminals



Figure 4.44.3 Testing 24V DC output on PSU Terminals

Multimeter set to measure DC voltage. PSU is correctly feeding 24.15 Vdc to the system.



Figure 4.44.4 Correct PSU DC Voltage Indicated on Multimeter

4.45 Appendix C: Changelog

Content from: 3ntr Industrial Grade 3D Printers: Maintenance Manual v 1.18

- 6-07-2017 v1.11: Added weird LCD behavior
- 10-07-2017 v1.12: Print server doesn't start prints
- 4-9-2017 v1.13: dead axis + dead cooling pics
- 18-9-2017 v1.14: Always check fuse with multimeter
- 30-10-2017 v1.15: Z safety switch
- 20-02-2018 v1.16: Silent stepper driver – tripped Z switch
- 24-05-2018 V1.18: Can't flash firmware – Z defects updated

TRAK Machine Tools
Southwestern Industries, Inc

TRAK Warranty Policy

Warranty

TRAK products are warranted to the original purchaser to be free from defects in workmanship and materials for the following periods:

Product	Warranty Period	
	Materials	Factory Labor
New TRAK/ProtoTRAK	1 Year	1 Year
Any EXCHANGE Unit	90 Days	90 Days

The warranty period starts on the date of the invoice to the original purchaser from Southwestern Industries, Inc. (SWI) or their authorized distributor.

If a product, subsystem or component proves to be defective in workmanship and fails within the warranty period, it will be repaired or exchanged at our option for a properly functioning unit in similar or better condition. Such repairs or exchanges will be made FOB Factory/Los Angeles or the location of our nearest factory representative or authorized distributor.

Disclaimers of Warranties

- This warranty is expressly in lieu of any other warranties, express or implied, including any implied warranty of merchantability or fitness for a particular purpose, and of any other obligations or liability on the part of SWI (or any producing entity, if different).
- Warranty repairs/exchanges do not cover incidental costs such as installation, labor, freight, etc.
- SWI is not responsible for consequential damages from use or misuse of any of its products.
- TRAK products are precision mechanical/electromechanical/electronic systems and must be given the reasonable care that these types of products require. Evidence that the product does not receive adequate Preventative Maintenance may invalidate the warranty. Excessive chips built up around ballscrews and way surfaces is an example of this evidence.
- Accidental damage, beyond the control of SWI, is not covered by the warranty. Thus, the warranty does not apply if a product has been abused, dropped, hit or disassembled.
- Improper installation by or at the direction of the customer in such a way that the product consequently fails, is considered to be beyond the control of the manufacturer and outside the scope of the warranty.
- Warranty does not cover wear items that are consumed under normal use of the product. These items include, but are not limited to: windows, bellows, wipers, filters, drawbars and belts.